

DOCUMENT RESUME

ED 132 391

CE 009 166

AUTHOR Lee, Eilly D.; Ragazzi, Ronald
 TITLE Automotive Emission Control.
 INSTITUTION Colorado State Board for Community Colleges and Occupational Education, Denver.; Colorado State Univ., Ft. Collins. Dept. of Industrial Sciences.
 SPONS AGENCY Mid-America Vocational Curriculum Consortium, Stillwater, Okla.
 PUB DATE 76
 NOTE 279p.
 EDRS PRICE MF-\$0.83 Plus Postage. HC Not Available from EDRS.
 DESCRIPTORS *Air Pollution Control; *Auto Mechanics; *Behavioral Objectives; Curriculum Guides; Instructional Materials; *Learning Activities; *Motor Vehicles; Teaching Guides; *Unit Plan; Vocational Education

ABSTRACT

This guide designed to assist teachers in improving instruction in the area of automotive emission control curriculum includes four areas. Each area consists of one or more units of instruction, with each instructional unit including some or all of the following basic components: Performance objectives, suggested activities for teacher and students, information sheets, assignment sheet, job sheets, visual aids, tests and test answers. (Units are planned for more than one lesson or class period of instruction.) The four major areas (and their respective units) are (1) Engine Pollutants (Introduction to Automotive Emission Control, Internal Combustion Engine Pollutants, Origin of Internal Combustion Engine Pollutants); Pre-Combustion Controls (Heated Air Induction Systems, Evaporative Emission System); Combustion Controls (Engine Modifications, Carburetor Modifications, Ignition Timing Systems, Transmission Controlled Spark System, Electronic Spark Control System, Exhaust Gas Recirculation System); and Post-Combustion Controls (Positive Crankcase Ventilation Systems, Air Injection System, Catalytic Converter Systems). (WL)

 * Documents acquired by ERIC include many informal unpublished *
 * materials not available from other sources. ERIC makes every effort *
 * to obtain the best copy available. Nevertheless, items of marginal *
 * reproducibility are often encountered and this affects the quality *
 * of the microfiche and hardcopy reproductions ERIC makes available *
 * via the ERIC Document Reproduction Service (EDRS). EDRS is not *
 * responsible for the quality of the original document. Reproductions *
 * supplied by EDRS are the best that can be made from the original. *

ED132391

AUTOMOTIVE EMISSION CONTROL

Developed by
Billy D. Lee
and
Ronald Raquet
Department of Industrial Sciences
Colorado State University
Fort Collins, Colorado

In Cooperation with the
Occupational Education Division
State Board for Community Colleges and Occupational Education
207 State Services Building
Denver, Colorado

PERMISSION TO REPRODUCE THIS
COPYRIGHTED MATERIAL BY MICRO-
FICHE ONLY HAS BEEN GRANTED BY
[Signature]

TO ERIC AND ORGANIZATIONS OPERAT-
ING UNDER AGREEMENTS WITH THE NA-
TIONAL INSTITUTE OF EDUCATION
FURTHER REPRODUCTION OUTSIDE
THE ERIC SYSTEM REQUIRES PERMIS-
SION OF THE COPYRIGHT OWNER

Disseminated by the
Mid America Vocational Curriculum Consortium, Inc.

U.S. DEPARTMENT OF HEALTH
EDUCATION & WELFARE
NATIONAL INSTITUTE OF
EDUCATION
THIS DOCUMENT HAS BEEN REPRO-
DUCED EXACTLY AS RECEIVED FROM
THE PERSON OR ORGANIZATION ORIGIN-
ATING IT. POINTS OF VIEW OR OPINIONS
STATED DO NOT NECESSARILY REPRESENT
OFFICIAL NATIONAL INSTITUTE OF
EDUCATION POSITION OR POLICY

Board of Directors
Bob Perry, Colorado
Amos Herd, Missouri
Grady Knight, Arkansas
Bob Patton, Oklahoma
W. A. Rumbaugh, Kansas
George Amshury, New Mexico
Merle Rudebusch, Nebraska
Don Eshelby, North Dakota
L. A. Iverson, South Dakota
W. H. Fitz, Texas
Robert Kerwood, Arizona

1976

CC 669 / 66

Copyright 1976
Mid America Vocational Curriculum Consortium, Inc.

Printed by
State Department of Vocational and Technical Education
Stillwater, Oklahoma 74074

AUTOMOTIVE EMISSION CONTROL
CURRICULUM

CONTENTS

INTRODUCTION TO AUTOMOTIVE EMISSION CONTROL	Unit 1
INTERNAL COMBUSTION ENGINE POLLUTANTS	Unit 2
ORIGIN OF INTERNAL COMBUSTION ENGINE POLLUTANTS	Unit 3
PRE-COMBUSTION CONTROLS	
HEATED AIR INDUCTION SYSTEMS	Unit 4
EVAPORATIVE EMISSION SYSTEM	Unit 5
COMBUSTION CONTROLS	
ENGINE MODIFICATIONS	Unit 6
CARBURETOR MODIFICATIONS	Unit 7
IGNITION TIMING SYSTEMS	Unit 8
TRANSMISSION CONTROLLED PARK SYSTEM	Unit 9
ELECTRONIC SPARK CONTROL SYSTEM	Unit 10
EXHAUST GAS RECIRCULATION SYSTEM	Unit 11
POST-COMBUSTION CONTROLS	
POSITIVE CRANKCASE VENTILATION SYSTEMS	Unit 12
AIR FJECTION SYSTEM	Unit 13
CATALYTIC CONVERTER SYSTEMS	Unit 14

FOREWORD

The Mid-America Vocational Curriculum Consortium, Inc. is proud to have drawn together the best vocational materials in the vocational states to create the model state. It is our hope that the National Automotive Technicians Council, as well as other important organizations of education at this time, its members of MAAVC and especially pleased to have the opportunity to disseminate this publication which was developed by the Department of Industrial Sciences at Colorado State University.

The purpose of this publication is to assist teachers in improving instruction. As these materials are used, it is hoped that student performance will improve and that students will be better prepared to assume a job in a mechanical occupation.

Another benefit resulting from this publication is an idea in terms of student performance test development objectives. It is an innovative approach to teaching that accents and supports the student learning process. Common referenced examination instruments are developed to determine the attainment of student progress. In addition to evaluating recall information, the tests are designed to evaluate the other areas including process and problem-solving skills of the students in an instructional unit.

Finally, the authors would like to thank this publication for its contribution to the industry, the vocational states, and the instructors. It is our hope that this publication will be used as a model for other vocational states and curricula. These ideas are left to the discretion of the states and the instructors should capitalize on them. Only through the use of these ideas will we be a vital part of the learning curve of the world.

Ann Bellamy
Executive Director
Mid-America Vocational
Curriculum Consortium, Inc.

CONTENTS OF THIS PUBLICATION

Instructional Units

The Automotive Emission Control curriculum includes four units. Each unit consists of one or more units of instruction. Each instructional unit contains one or 2 of the basic components of a unit of instruction, performance objectives, varied activities for teacher and students, information sheets, assignment sheets, job sheets, visual aids, tests, and answers to the test. Units are planned for more than one lesson or class period of instruction.

Careful study of each instructional unit by the teacher will help to determine:

- A. The amount of material that can be covered in each class period.
- B. The skills which must be demonstrated.
 1. Supplies needed
 2. Equipment needed
 3. Amount of practice needed
 4. Amount of class time needed for demonstrations
- C. Supplementary materials such as pamphlets and filmstrips that must be ordered.
- D. Resource people that must be contacted.

Objectives

Each unit of instruction is based on performance objectives. These objectives state the goals of the course thus providing a sense of direction and accomplishment for the student.

Performance objectives are stated in two forms. Terminal objectives state the subject matter to be covered in a unit of instruction. Specific objectives state the student performance necessary to reach the terminal objective.

Since the objectives of the unit provide direction for the teaching/learning process, it is important for the teacher and students to have a common understanding of the intent of the objectives. A limited number of performance terms have been used in the objectives for this curriculum to assist in promoting the effectiveness of the communication among all individuals using the materials.

Following is a list of performance terms and their synonyms which may have been used in this material:

Name	<u>Identify</u>	<u>Describe</u>
Label	Select	Define
List in writing	Mark	Discuss in writing
List orally	Point out	Discuss orally
Letter	Pick out	Interpret
Record	Choose	Tell how
Repeat	Locate	Tell what
Give		Explain

Apply
Arrange
Sequence
List in order
Classify
Divide
Isolate
Sort

Distinguish
Discriminate

Construct
Draw
Make
Build
Design
Formulate
Reproduce
Transcribe
Reduce
Increase
Figure

Demonstrate
Show your work
Show procedure
Perform an experiment
Perform the steps
Operate
Remove
Replace
Turn off/on
(Dis) assemble
(Dis) connect

Reading of the objectives by the student should be followed by a class discussion to answer any questions concerning performance requirements for each instructional unit.

Teachers should feel free to add objectives which will fit the material to the needs of his students and community. When a teacher adds objectives, he should remember to supply the needed information, assignment and/or job sheets, and criterion tests.

Suggested Activities

Each unit of instruction has a suggested activities sheet outlining steps to follow in accomplishing specific objectives. The activities are listed according to whether they are the responsibility of the instructor or the student.

Instructor Duties of the instructor will vary according to the particular unit; however, for best use of the material they should include the following: provide students with objective sheet, information sheet, assignment sheets, and job sheets; prepare lessons, make arrangements, and arrange for resource materials and people; discuss terminal and specific objectives and information sheet; give test. Teachers are encouraged to use any additional instructional activities and teaching methods to aid student in accomplishing the objective.

Students Student activities are listed which will help the student to accomplish objectives for the unit.

Information Sheets

Information sheets provide content essential for meeting the cognitive and affective objectives of the unit. The teacher will find that information sheets serve as a excellent guide for presenting the background knowledge necessary to develop the skill specified in the terminal objectives.

Students should read the information sheets before the information is discussed in class. Students may take additional notes on the information sheets.

Transparency Material

Transparencies master procedures for use in a special class. Students may see as well as read the material being presented, thus reinforcing the learning process. Transparencies may present new information or they may reinforce information presented in the information sheets. They are particularly effective when identification is necessary.

Transparencies should be made and placed in the notebook where they will be immediately available for use. Transparencies direct the class's attention to the topic of discussion. They should be left on the screen only when topics shown are under discussion. (NOTE: Stand away from the overhead projector when discussing transparency material. The noise of the projector may cause the teacher to speak too loudly.)

Job Sheets

Job sheets are an important segment of training. The instructor should be able to and in most situations should demonstrate the skills outlined in the job sheets. Procedures outlined in the job sheets give direction to the skill being taught and allow both student and teacher to check student progress toward the accomplishment of the skill. Job sheets provide a ready outline for a student to follow if he has missed a demonstration. Job sheets also furnish potential employers with a picture of the skills being taught and the performances he might reasonably expect from a person who has had this training.

Assignment Sheets

Assignment sheets give direction to study and furnish practice for paper and pencil activities to develop the knowledge which are necessary prerequisites to skill development. These may be given to the student for completion in class or used for homework assignments. Answer sheets are provided which may be used by the student and/or teacher for checking student progress.

Test and Evaluation

Paper-pencil and performance tests have been constructed to measure student achievement of each objective listed in the unit of instruction. Individual test items may be pulled out and used as a short test to determine student achievement of a particular objective. This kind of testing may be used as a daily quiz and will help the teacher spot difficulties being encountered by students in their efforts to accomplish the terminal objective. Test items for objectives added by the teacher should be constructed and added to the test.

Test Answers

Test answers are provided for each unit. These may be used by the teacher and/or student for checking student achievement of the objectives.

INTRODUCTION TO AUTOMOTIVE

EMISSION CONTROL

UNIT 1

TERMINAL OBJECTIVE

After completion of this unit the student will be able to discuss the difference between smog, photochemical smog, sources of air pollution related to motor vehicles and the agency involved in the regulation of motor vehicle emissions.

This will be evidenced by scoring 85% minimum on the unit test.

SPECIFIC OBJECTIVES

After completion of this unit the student will be able to:

1. Explain in writing the difference between smog and photochemical smog.
2. Explain in writing the sources of air pollution related to motor vehicles.
3. Briefly describe in writing the federal agency involved in the regulation of motor vehicle emissions.
4. Write the definition of automotive emission control and list the three areas of automotive emission control.

INTRODUCTION TO AUTOMOTIVE

EMISSION CONTROL

UNIT 1

SUGGESTED ACTIVITIES

- I. Instructor
 - A. Provide students with objective sheet
 - B. Provide students with information sheets
 - C. Discuss terminal and specific objectives
 - D. Discuss information sheet
 - E. Give test
- II. Student
 - A. Read objective sheet
 - B. Study information sheet
 - C. Take test

INSTRUCTIONAL MATERIALS

- I. Included in this unit:
 - A. Objective sheet
 - B. Information sheets
 - C. Transparency masters
 - 1-TM-1 Photochemical Smog Over City
 - D. Test
 - E. Answers to test

II. References

- A. Air Pollution Control Division, Colorado Department of Health -
The Colorado Plan for the Control of Motor Vehicle Emissions,
Interim Report, February 8, 1973.
- B. Gargano Promotions. Vehicle Emission Control, 12824 West Seven
Mile Road, Detroit, Mich. 48235, Gargano Promotions, (1973).
- C. Glenn, Harold T. Glenn's Emission Control Systems, Chicago, Ill.,
Henry Regrery Co., (1972).
- D. Pryde, Lucy T. Environmental Chemistry - An Introduction,
Cummings Publishing Co., Inc., 2727 Sandhill Road, Menlo Park,
CA 94025, (1973).
- E. Williamson, S. J. Fundamentals of Air Pollution, Addison-
Wesley Publishing Co., Reading, Mass.; Menlo Park, Calif.; London;
Ontario, (1973).

INTRODUCTION MOTOR VEHICLE

EMISSION CONTROL

UNIT 1

INFORMATION SHEET

I. DISCUSSION

- A. Smog was described as a condition resulting from the mixing of smoke and fog. This condition has existed for some time in different parts of the world. It is attributed to the death of several hundred people.
- B. Photochemical smog is a condition that results from hydrocarbons and oxides of nitrogen chemically changing in the presence of sunlight. This condition can cause burning of the eyes, lung irritation, plant damage, the cracking of rubber and possibly death. TM-1

II. SOURCES OF AIR POLLUTION RELATED TO MOTOR VEHICLES

- A. Combustion is the oxidation or burning of any substance that can be used as a fuel. The results of this combustion give off hydrocarbons, carbon monoxide and oxides of nitrogen, all of which are considered air pollutants.
- B. Other pollutants contributed by motor vehicles are the evaporation of liquid fuel to the atmosphere, parts of the fuel itself; i.e., lead and sulfur, as well as asbestos from brake linings and rubber from the tires.

III. FEDERAL AGENCY INVOLVED IN THE REGULATION OF MOTOR VEHICLE EMISSIONS

In 1970 the Clean Air Act was enacted into law. To aid in carrying out the Clean Air Act, the Environmental Protection Agency (EPA)

are also established. The national air quality standards are established to aid the states in attaining the national air quality standards. In 1971, the EPA established national standards for ambient air quality. The standards set the limits for sulfur dioxide, carbon monoxide, oxides of nitrogen, and particulates. Motor vehicles contribute approximately 25% of the total hydrocarbon, carbon monoxide and oxides of nitrogen that are emitted into the atmosphere. For this reason, the federal government has state and the automobile manufacturers are attempting to reduce the total contribution of pollutants emitted by the vehicles.

IV. DEFINITION OF AUTOMOTIVE EMISSIONS CONTROL SYSTEM AS POLLUTION SOURCE FROM THE AUTOMOBILE

V. DISCUSSION

The automobile depends on the internal combustion engine for its power. The combustion of fuel in the internal combustion engine is responsible for a large majority of the pollutants emitted to the atmosphere. *Automotive emissions control systems* are divided into three groups:

- 1) The combustion system, which includes the fuel injection system, the carburetor, the air filter, the spark plug, the exhaust valve, and the exhaust system, located in the engine compartment.
- 2) The exhaust system, which includes the catalytic converter, the muffler, and control valve located in the exhaust system. It is also responsible for the catalytic converter, particulate filter, and other devices.
- 3) The emission control system, which includes the evaporative emission control system, the crankcase emission control system, and the oil separator.

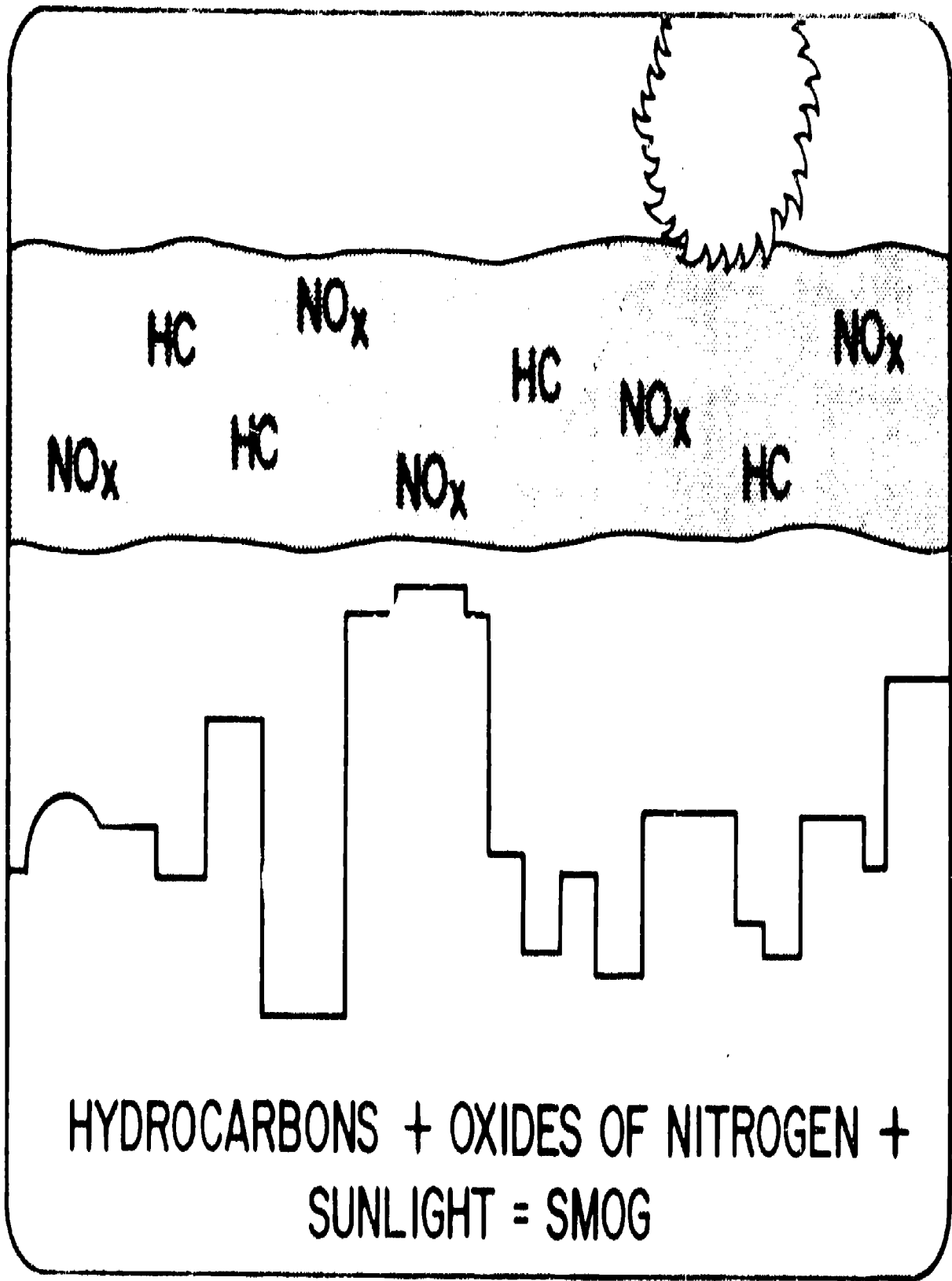

INTRODUCTION TO AUTOMOTIVE

EMISSION CONTROL

UNIT 1

T E S T

1. Explain in writing the difference between smog and photochemical smog.
2. Explain in writing the sources of air pollution related to motor vehicles.
3. Briefly describe in writing the federal agency involved in the regulation of motor vehicle emissions.
4. Write the definition of automotive emission control and list the three areas of automotive emission control.

INTRODUCTION TO AUTOMOTIVE

EMISSION CONTROL

UNIT 1

ANSWERS TO TEST

1. Explain in writing the difference between smog and photochemical smog. Smog results from the mixing of smoke and fog. Photochemical smog results from hydrocarbons and oxides of nitrogen chemically changing in the presence of sunlight.
2. Explain in writing the sources of air pollution related to motor vehicles. Unburned hydrocarbons, oxides of nitrogen and carbon monoxide resulting from the combustion process. Also hydrocarbons from the evaporation of liquid fuel. Parts of the fuel such as lead and sulfur as well as asbestos from brake linings and rubber from the tires.
3. Briefly describe in writing the federal agency involved in the regulation of motor vehicle emissions.

The Environmental Protection Agency (EPA) which was established in 1970. One of the EPA's primary responsibilities is to aid the states in attaining a desirable air quality standard. The EPA sets the limits for hydrocarbons, carbon monoxide and oxides of nitrogen and particulates.

4. Write the definition of automotive emission control and list the three areas of automotive emission control.

Definition - Any control that reduces pollutant emissions from the automobile.

Three areas of control -

- (1) Pre-combustion controls - devices or systems that reduce emissions before combustion takes place.
- (2) Combustion controls - devices or systems that actually effect and control combustion to reduce emissions.

- (3) Post-combustion controls - devices or systems that reduce emissions after combustion has occurred.

INTERNAL COMBUSTION ENGINE POLLUTANTS

UNIT 2

TERMINAL OBJECTIVE

After completion of this unit the student will be able to define the major pollutants emitted from the internal combustion engine and give further explanation of the part each plays in air pollution and/or health problems.

This will be evidenced by scoring 85% minimum on the unit test.

SPECIFIC OBJECTIVES

After completion of this unit the student will be able to:

1. Write the definition of hydrocarbons (HC).
2. Explain in writing the part hydrocarbons (HC) play in the formation of smog.
3. Write the definition of oxides of nitrogen (NO_x).
4. Explain in writing the part oxides of nitrogen (NO_x) play in the formation of smog.
5. Write the definition of carbon monoxide (CO).
6. Explain in writing the health hazards of carbon monoxide (CO).
7. Write the definition of particulates.
8. Explain in writing the health hazards of particulates.

INTERNAL COMBUSTION ENGINE POLLUTANTS

UNIT 2

SUGGESTED ACTIVITIES

- I. Instructor
 - A. Provide students with objective sheet
 - B. Provide students with information sheets
 - C. Discuss terminal and specific objectives
 - D. Discuss information sheets
 - E. Give test
- II. Student
 - A. Read objective sheet
 - B. Study information sheet
 - C. Take test

INSTRUCTIONAL MATERIALS

- I. Included in this unit:
 - A. Objective sheet
 - B. Information sheets
 - C. Transparency masters
 - 2-TM-1 - Hydrocarbons
 - 2-TM-2 - NO_x Formation
 - 2-TM-3 - Carbon Monoxide Formation
 - 2-TM-4 - Particulates
 - D. Test
 - E. Answers to test

II. References

- A. Patterson, D. J. and Henein, N. A. Emissions from Combustion Engines and Their Control, Ann Arbor Science Publishers, Inc., Ann Arbor, Mich. (1973).
- B. Springer, G. S. and Patterson, D. J. Engine Emissions Pollutant Formation and Measurement, Plenum Press, 227 W. 17th Street, New York, N.Y. (1973).
- C. Williamson, S. J. Fundamentals of Air Pollution, Addison-Wesley Publishing Co., Reading, Mass.; Menlo Park, Calif.; London; Ontario (1973)

INTERNAL COMBUSTION ENGINE POLLUTANTS

UNIT 2

INFORMATION SHEET

- I. DEFINITION OF HYDROCARBONS (HC) - Hydrocarbons are compounds made up of hydrogen (H) atoms and carbon (C) atoms. TM-1
- II. DISCUSSION
- A. Petroleum products such as gasoline and fuel oil consist of hundreds of different hydrocarbon compounds. One hundred percent (100%) complete combustion of all the fuel does not occur in the internal combustion engine and consequently some of the hydrocarbon compounds that do not burn escape to the atmosphere and are called unburned hydrocarbons.
- B. Some of these unburned hydrocarbon compounds are chemically active, that is, they combine with other compounds. Some unburned hydrocarbons tend to combine with nitrogen dioxide (NO_2). This combination in the presence of sunlight causes the formation of smog and the resultant eye and lung irritations.
- III. DEFINITION OF OXIDES OF NITROGEN (NO_x) - The chemical combination of nitrogen (N) and oxygen (O) during the combustion process. TM-2
- IV. DISCUSSION
- A. During the combustion process in the internal combustion engine high temperatures are reached that cause the formation of oxides of nitrogen (NO_x). NO_x is made up of 97-98% nitric oxide (NO) and 2-3% nitrogen dioxide (NO_2). Nitric oxide is a colorless gas but when it is exhausted to the atmosphere it combines with oxygen (O_2) to form nitrogen dioxide (NO_2) which has a brownish color.
- B. Nitrogen dioxide (NO_2) in the atmosphere combines with certain chemically active hydrocarbons and in the presence of sunlight causes the formation of smog.

V. DEFINITION OF CARBON MONOXIDE (CO) - An odorless, colorless, toxic gas that results from incomplete combustion. TM-3

VI. DISCUSSION

A. If combustion was 100% complete in the internal combustion engine, the only end products would be carbon dioxide (CO₂) and water (H₂O). Combustion is not 100% complete and the result is the exhausting of carbon monoxide to the atmosphere.

B. Carbon monoxide (CO) is a toxic gas. When it is inhaled into the lung and transferred to the blood stream it takes the place of oxygen in the red blood cells. As more carbon monoxide is taken up in the red blood cells, the amount of oxygen being supplied to the body is reduced. This lack of oxygen to the body can cause headaches, reduced mental alertness and even death if carbon monoxide concentrations are high enough.

VII. DEFINITION OF PARTICULATES - Solid particles, primarily of lead and carbon that are exhausted to the atmosphere. TM-4

VIII. DISCUSSION

The carbon emitted to the atmosphere comes primarily from hydrocarbon fuels and oils. The lead emitted comes from the tetra-ethyl lead added to fuels to increase their octane rating. The lead emitted to the atmosphere poses a health threat in two ways:

1. Respiratory intake of airborne lead during breathing.
2. Contamination of food by lead that has settled in the soil. Lead is a toxic substance and high concentrations of lead in the body can cause damage to the brain, nervous system and kidneys and can cause death.

HYDROCARBONS

GASOLINE
AND
DIESEL & OIL

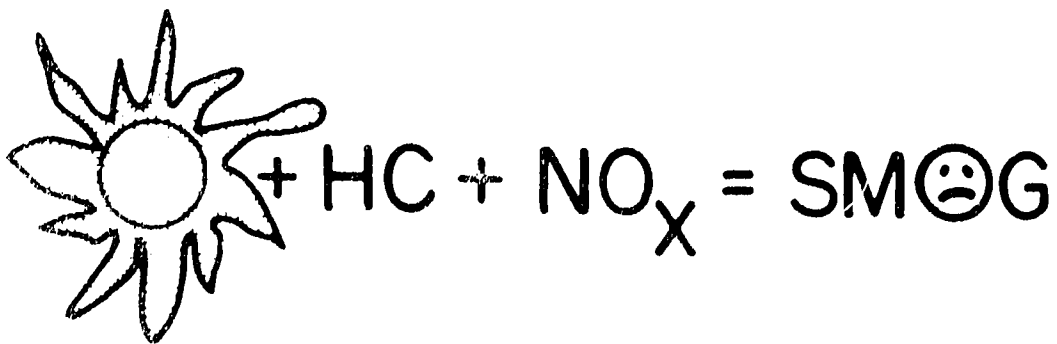
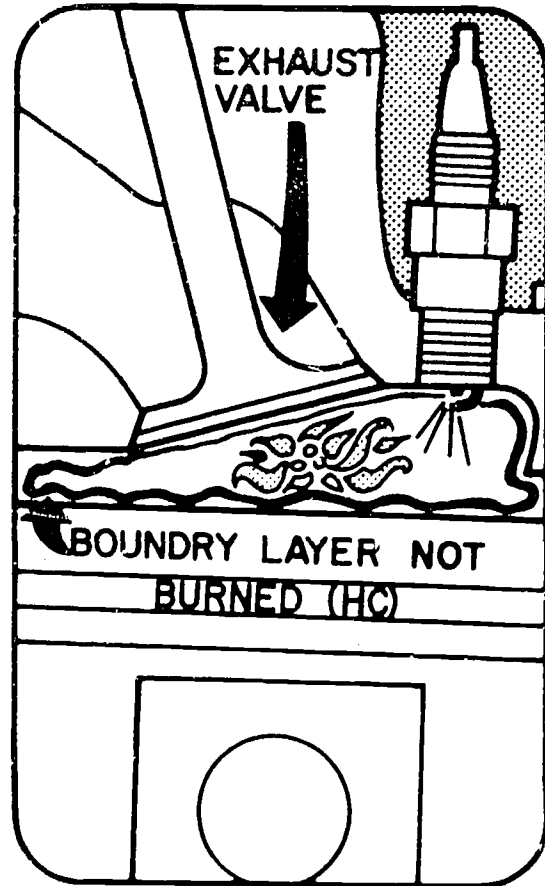
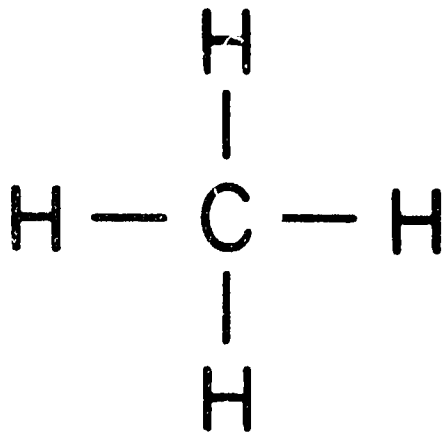

NO_x FORMATION

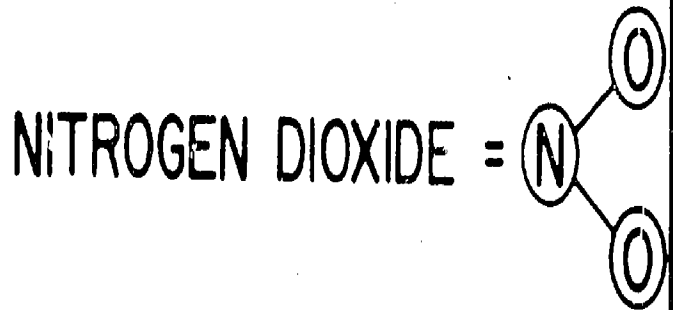
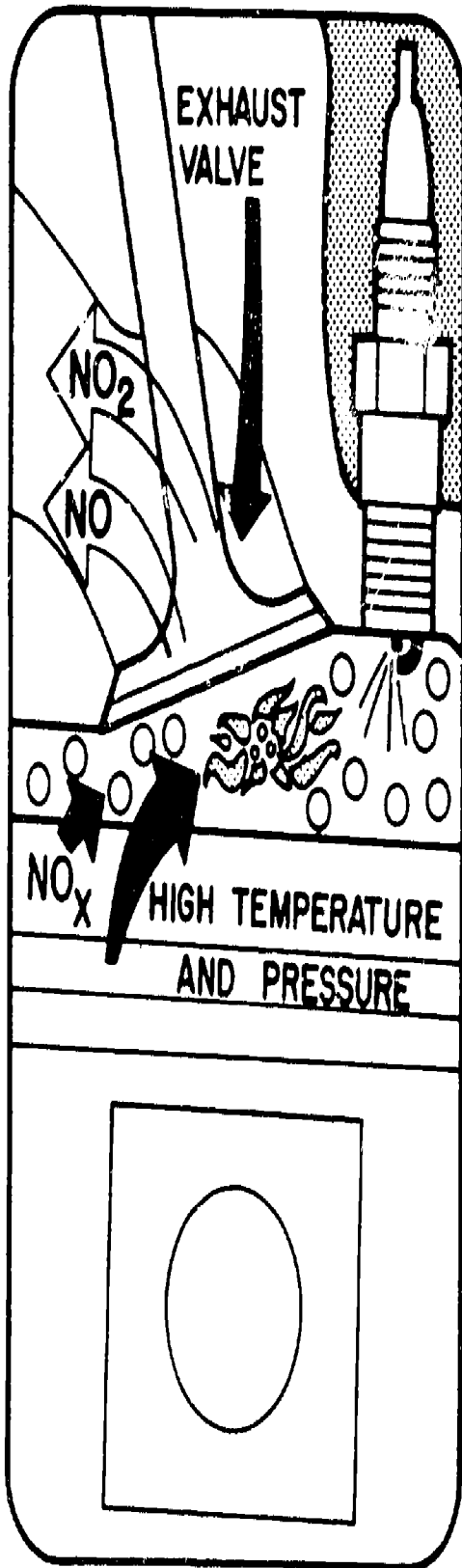

NITROGEN COMBINES
WITH OXYGEN
UNDER PRESSURE
AND TEMPERATURE
NO_x IS NO AND NO₂

CARBON MONOXIDE FORMATION

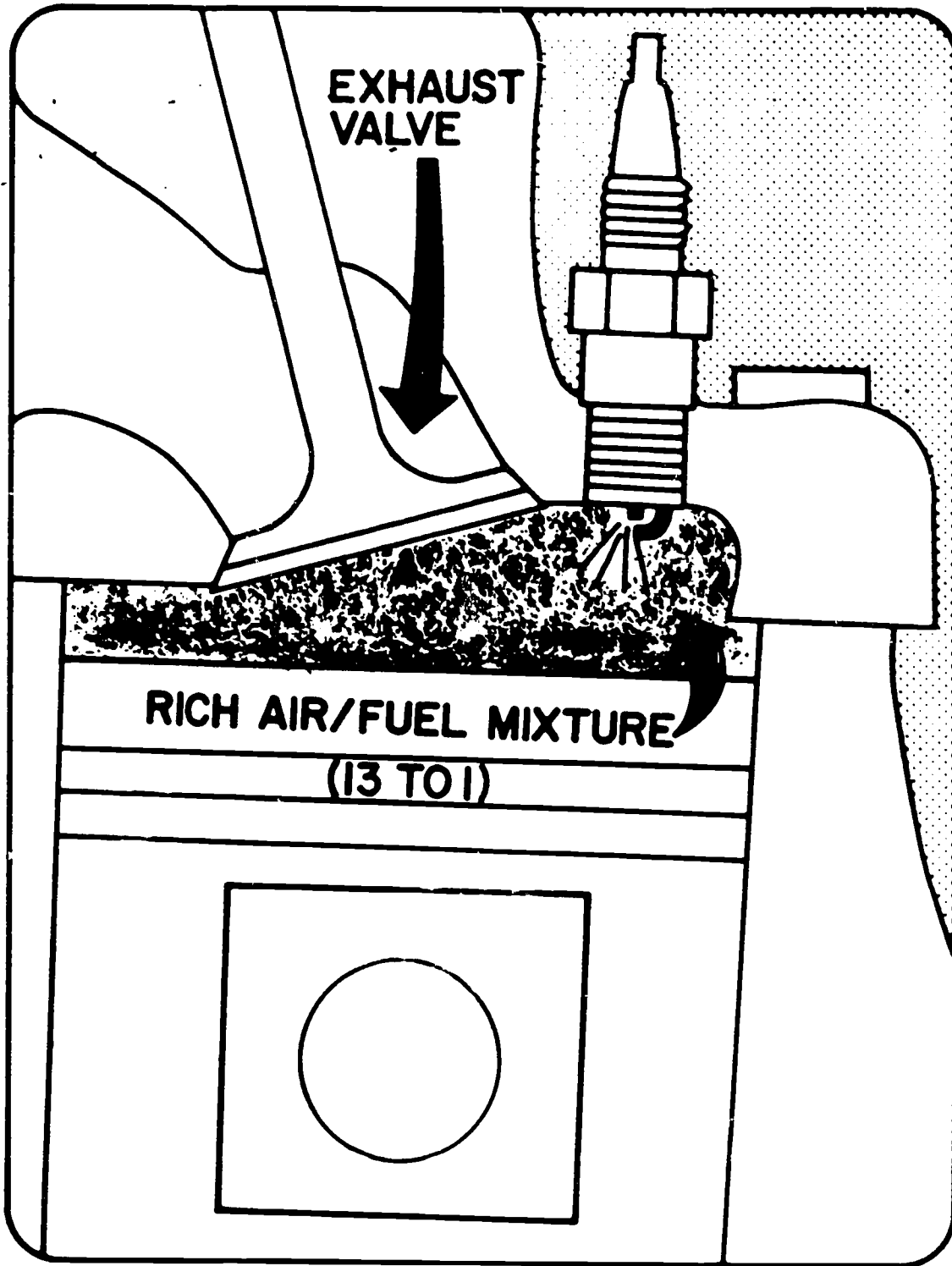

PARTICULATES

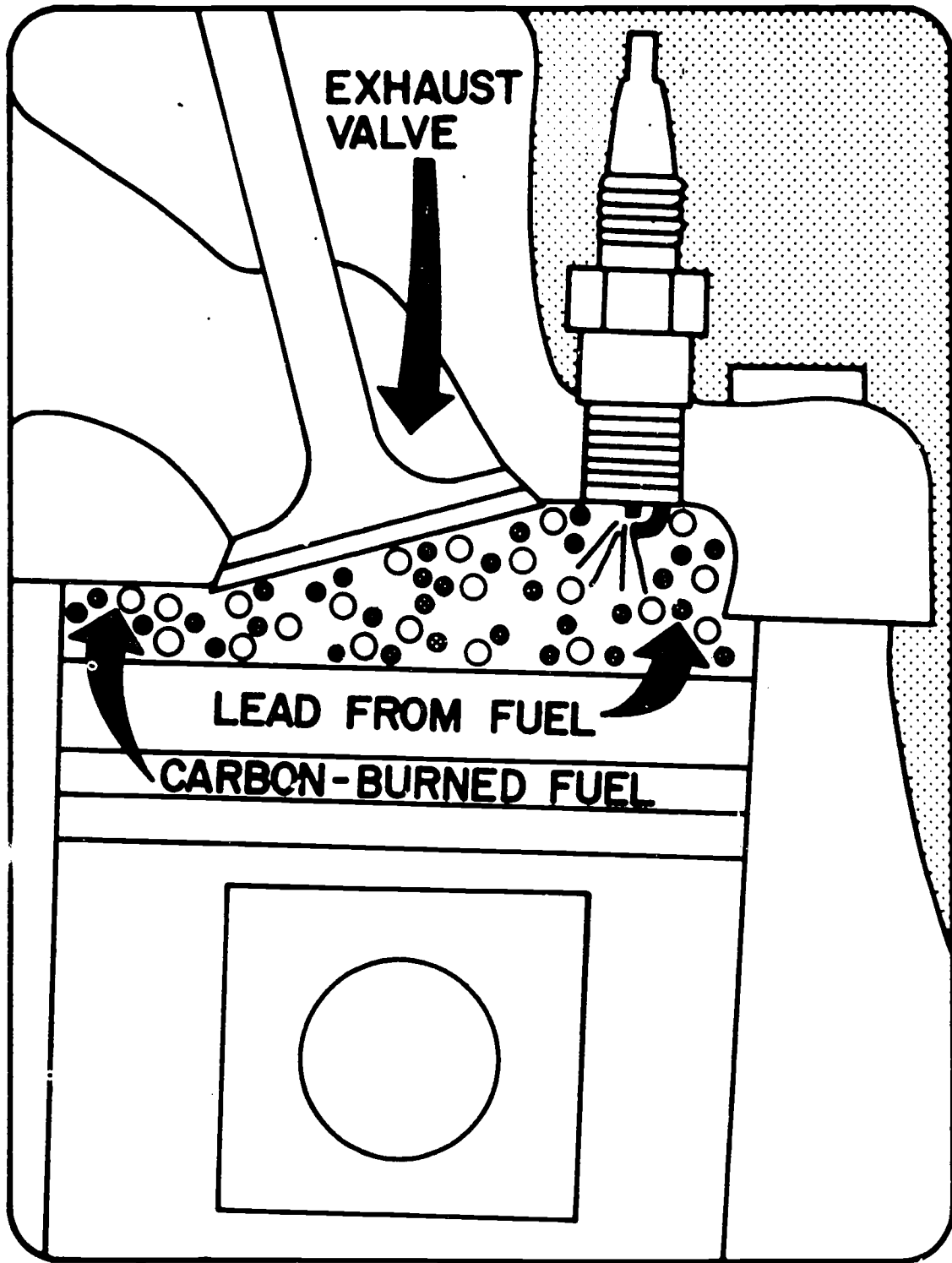

INTERNAL COMBUSTION ENGINE POLLUTANTS

UNIT 2

T E S T

1. What is HC?
2. What part does HC play in the formation of smog?
3. What is the definition of NO_x ?
4. What part does NO_x play in the formation of smog?
5. What is CO?
6. Why is CO a health hazard?
7. What is the definition of particulates?
8. Explain the health hazards of particulates.

INTERNAL COMBUSTION ENGINE POLLUTANTS

UNIT 2

ANSWERS TO TEST

1. What are hydrocarbons?

Compounds made up of hydrogen atoms and carbon atoms.

2. What part do hydrocarbons have in the formation of smog?

Chemically active hydrocarbons combine with nitrogen dioxide and in the presence of sunlight form smog.

3. What is the definition of oxides of nitrogen?

The chemical combination of nitrogen and oxygen during the combustion process.

4. What part does NO_x take in the formation of smog?

Nitric oxide combines with oxygen in the atmosphere to produce nitrogen dioxide. Nitrogen dioxide combines with chemically active hydrocarbons and in the presence of sunlight forms smog.

5. What is carbon monoxide?

An odorless, colorless, toxic gas that results from incomplete combustion.

6. Why is carbon monoxide a health hazard?

Because it takes the place of oxygen in the red blood cells and reduces the amount of oxygen the body can receive. It can cause headaches and in large concentrations it can cause death.

7. What is the definition of particulates?

Solid particles primarily of lead and carbon that are exhausted to the atmosphere.

8. Explain the health hazards of particulates.

Carbon - none.

Lead - Toxic substance that can cause brain damage or death in high enough concentrations.

ORIGIN OF INTERNAL
COMBUSTION ENGINE POLLUTANTS

UNIT 3

TERMINAL OBJECTIVE

After completion of this unit the student will be able to explain the origin of each pollutant emitted from the internal combustion engine.

This will be evidenced by scoring 85% minimum on the unit test.

SPECIFIC OBJECTIVES

After completion of this unit the student will be able to:

1. List and explain the origins of unburned hydrocarbon (HC) emissions during normal combustion.
2. List and explain the causes of incomplete combustion that result in the emission of unburned HC.
3. Explain in writing the origin of carbon monoxide (CO) emissions.
4. Explain in writing the origin of nitric oxide (NO) emissions.
5. List and explain the engine variables affecting NO emissions.

ORIGIN OF INTERNAL
COMBUSTION ENGINE POLLUTANTS

UNIT 3

SUGGESTED ACTIVITIES

- I. Instructor
 - A. Provide students with objective sheet
 - B. Provide students with information sheets
 - C. Make transparencies
 - D. Discuss information sheets
 - E. Give test
- II. Student
 - A. Read objective sheet
 - B. Study information sheet
 - C. Take test

INSTRUCTIONAL MATERIALS

- I. Included in this unit:
 - A. Objective sheet
 - B. Information sheets
 - C. Transparency masters
 - 3-TM-1 - Combustion Chamber Quench Areas
 - 3-TM-2 - Incomplete Combustion - Ignition System
 - 3-TM-3 - Incomplete Combustion - Fuel System
 - 3-TM-4 - HC-CO-NO Emission vs. A/F Mixture
 - D. Test
 - E. Answers to test

II. References

1. Ethyl Technical Notes, 1777 S. Bellaire, Denver, Colorado.
Combustion in the Automotive Engine, Revised.
2. Glenn, Harold T. Glenn's Emission Control Systems, Chicago, Ill.,
Henry Regnery Co., (1972).
3. Heinen, C. M. We've Done the Job - What's Next? SAE Vehicle
Emissions, Part III, Vol. 14 P.T.
4. Henein, N. A. and Patterson, D. J. Emissions From Combustion
Engines and Their Control, Ann Arbor Science Publications, Inc.,
Ann Arbor, Mich. (1972).
5. Springer, G. S. and Patterson, D. J. Engine Emission Pollutant
Formation and Measurement, Plenum Press, 227 W. 17th Street,
New York, N. Y. (1973).

ORIGIN OF INTERNAL
COMBUSTION ENGINE POLLUTANTS

UNIT 3
INFORMATION SHEET

- I. ORIGINS OF UNBURNED HYDROCARBON EMISSIONS DURING NORMAL COMBUSTION - TM-1
- A. Wall Quenching - The failure of a layer of the air-fuel mixture next to the relatively cool combustion chamber walls to ignite. This is caused by the transfer of a large amount of heat from the fuel mixture to the combustion chamber walls and results in a fuel mixture that is too cool to ignite and which will remain unburned throughout the combustion process.
 - B. Quench Areas - Small areas and cavities in the combustion chamber where the flame is quenched allowing a small amount of unburned fuel to remain. These areas are formed by: (1) improperly fitted head gaskets that leave a small cavity in the combustion chamber, (2) the area between the top compression ring and the top of the piston, (3) the actual "squish" area of the combustion chamber and (4) the area around the porcelain of the center electrode of the spark plug.
 - C. Combustion Chamber Deposits - Combustion chamber deposits are fairly porous and act as sponges to absorb a small amount of the fuel. This small amount of fuel is released late in the power stroke or exhaust stroke as a vapor and is exhausted to the atmosphere.

II. CAUSES OF INCOMPLETE COMBUSTION THAT RESULT IN UNBURNED HYDROCARBON EMISSIONS.

- A. Ignition System - TM-2 - Any component of the ignition system that is worn or out of adjustment may cause a weak spark or a misfire to occur. Either of these conditions will cause incomplete combustion and result in the emission of a large amount of unburned hydrocarbons.
- B. Low Air-Fuel Mixture Temperature - TM-3 - Low air-fuel mixture temperatures result in the poor atomization of fuel. This reduces the mixing of air and fuel and results in an unevenly mixed air-fuel mixture. This type of mixture has high local concentrations of excessively rich mixtures and lean mixtures and when ignited will not burn evenly. This results in the emission of a large amount of unburned hydrocarbons.
- C. Too Rich or Too Lean Air-Fuel Mixtures - A mixture that is too rich does not have enough oxygen to completely burn the amount of fuel present. This results in the emission of a large amount of unburned hydrocarbons and carbon monoxide. Mixtures that are too lean can result in a misfire because the fuel is so diluted by air that it will not ignite.
- D. Excessive Exhaust Gas Dilution - Excessive exhaust gas dilution occurs primarily during high manifold vacuum conditions such as engine idle or deceleration. This dilution of the air-fuel mixture results in a mixture that will not burn completely or a complete misfire. Either condition will result in high hydrocarbon emissions.

III. ORIGIN OF CARBON MONOXIDE EMISSIONS - TM-4

Carbon monoxide (CO) is formed during the combustion process when there is not enough oxygen available to convert (CO) to carbon dioxide (CO₂). As the air-fuel mixture becomes richer than the ideal ratio of 15:1 there is an insufficient amount of oxygen present to complete the combustion process. This shortage of oxygen results in the incomplete conversion of (CO) to (CO₂). An increase in the (CO) emissions is normally accompanied by an increase in (HC) emissions because of the lack of oxygen to completely burn all the fuel mixture.

IV. ORIGIN OF OXIDES OF NITROGEN (NO_x) EMISSIONS - TM-4

The formation of nitric oxides (NO) takes place during the highest temperatures of the combustion process. Air is made up of approximately 78% nitrogen and 21% oxygen. This air is drawn into the engine and mixed with fuel. The mixture of air and fuel is then ignited and temperatures in excess of 2700°C(4500°F) may be reached. At temperatures above approximately 1357°C(2500°F) (NO) is formed very quickly from the large amount of nitrogen and oxygen in the air. The formation of nitric oxide is dependent on temperature and any engine variable that causes an increase in temperature above approximately 1082°C(2000°F)-1357°C(2500°F) will cause an increase in NO emissions.

V. ENGINE VARIABLES AFFECTING NO_x EMISSIONS

- A. Ignition Timing - As ignition timing is advanced more of the mixture is burned before the piston reaches top dead center (TDC). This causes increased pressures and temperatures in the combustion chamber which result in increased NO_x emissions. As timing is retarded more of the mixture is burned on the power stroke and lower temperatures and pressures result in a decrease in NO_x emissions.

B. Air-Fuel Mixture - For fuel mixtures richer than 15:1 there is not enough oxygen to completely burn the mixture. This lowers combustion temperatures and lowers NO_x emissions. For mixtures leaner than 15:1 combustion temperatures decrease because of the lack of fuel and NO_x emissions decrease. At 15:1 combustion temperatures are highest and NO_x emissions are highest.

NOTE: At 15:1 air-fuel ratio when NO_x emissions are highest, hydrocarbon and carbon monoxide emissions are lowest (TM-4).

C. Exhaust Gas Dilution - TM-3 - Exhaust gas dilution occurs during high intake manifold vacuum conditions such as idle or deceleration. The dilution of the air-fuel mixture with exhaust gases decreases the temperatures reached during combustion and lowers NO_x emissions.

COMBUSTION CHAMBER QUENCH AREAS

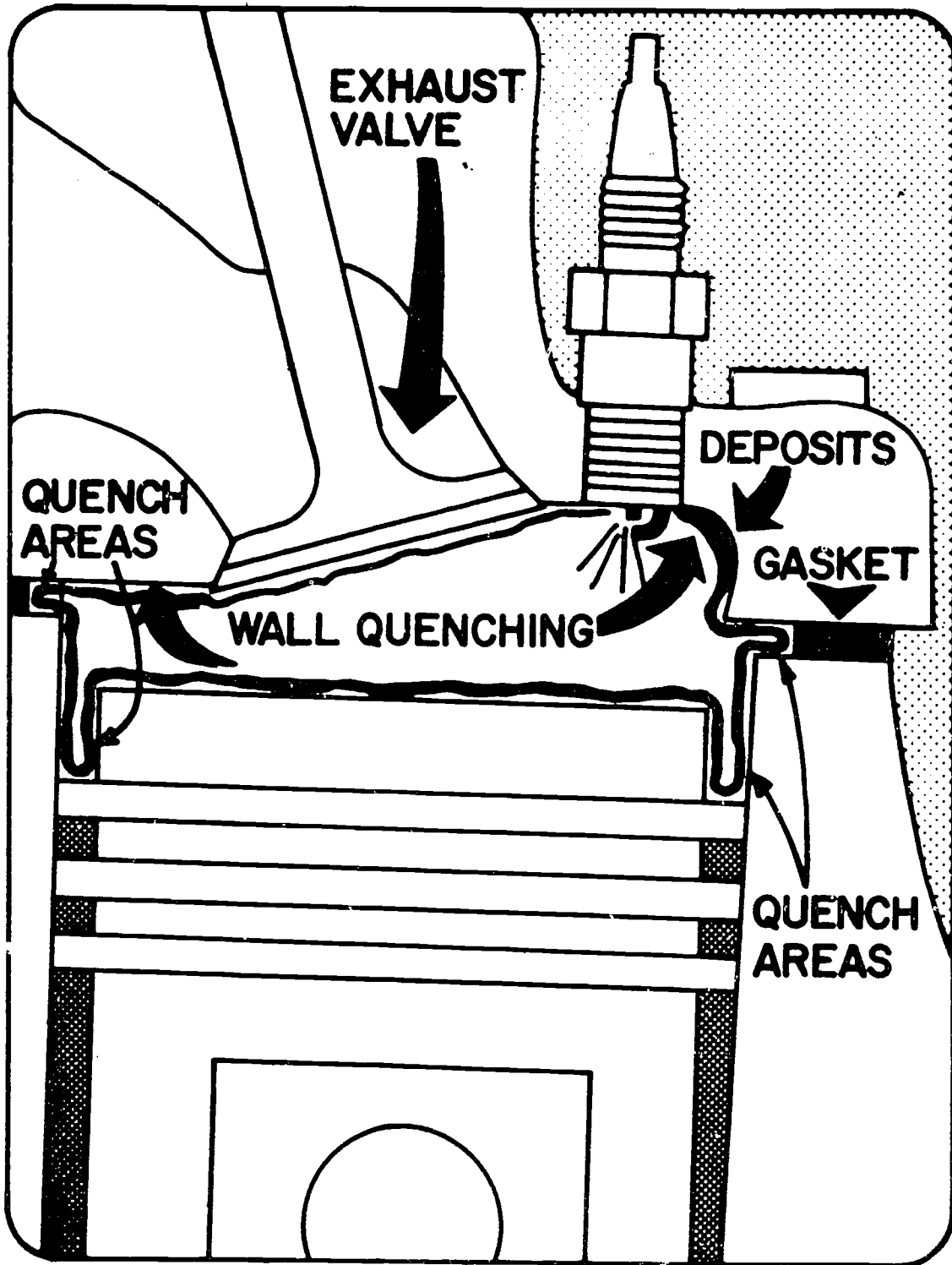

INCOMPLETE COMBUSTION - IGNITION SYSTEM

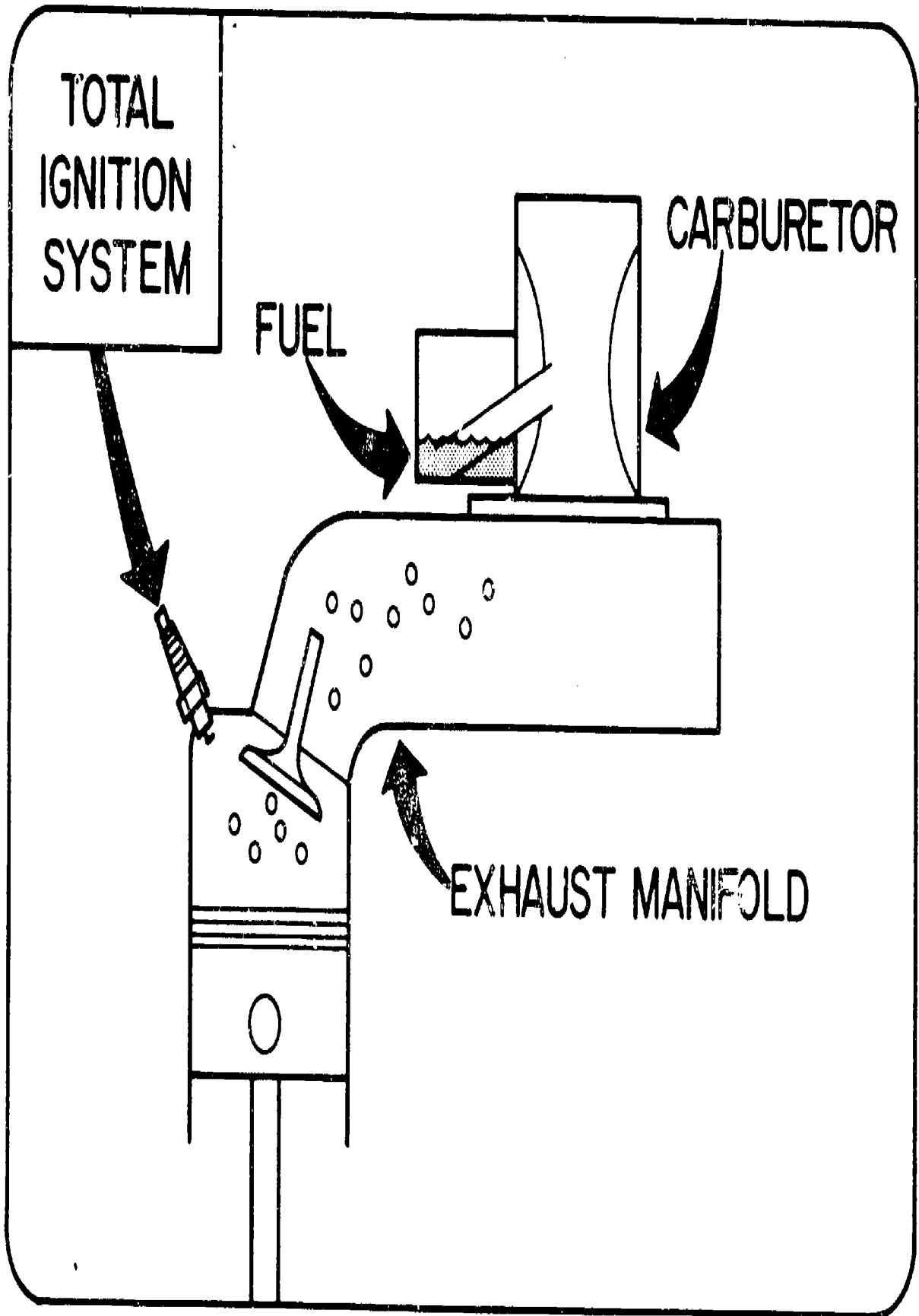

INCOMPLETE COMBUSTION - FUEL SYSTEM

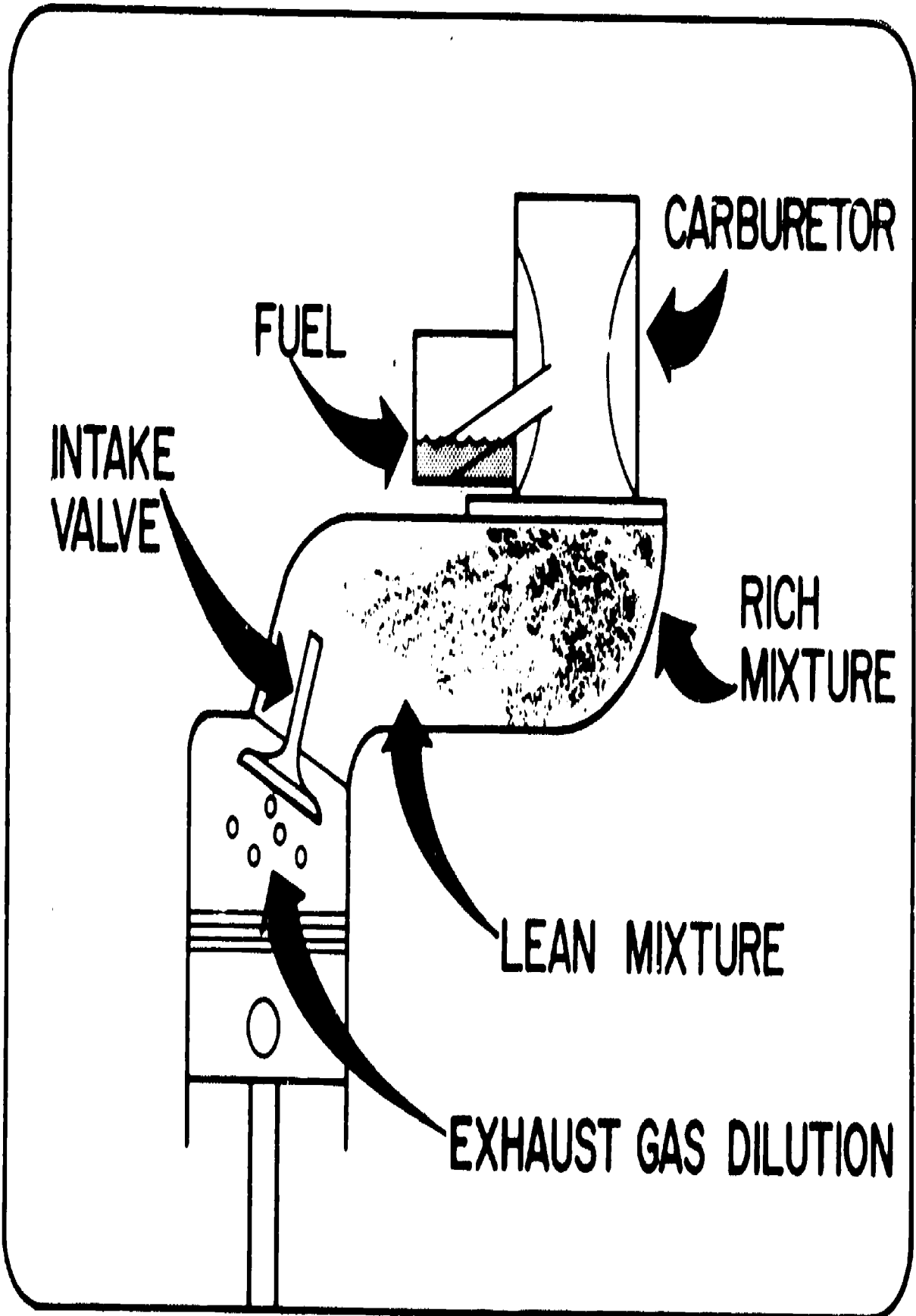

HC-CO-NO_x EMISSIONS vs A/F RATIO

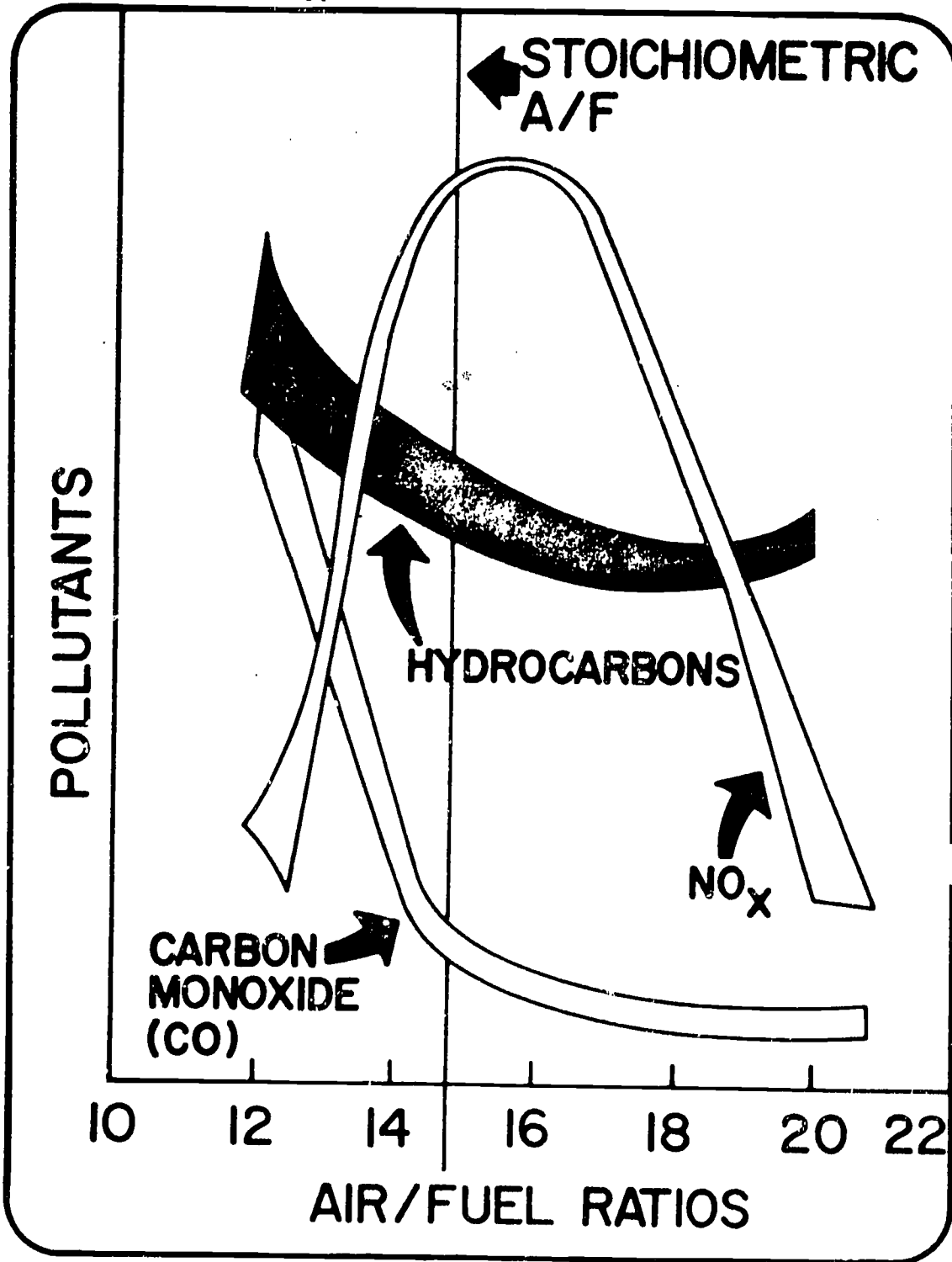

ORIGIN OF INTERNAL
COMBUSTION ENGINE POLLUTANTS

UNIT 3

T E S T

1. List and explain the origins of unburned HC emissions during normal combustion.

a.

b.

c.

2. List and explain the causes of incomplete combustion that result in HC emissions.

a.

b.

c.

d.

3. Explain the origin of (CO) emissions.

4. Explain the origin of (NO_x) emissions.

5. List and explain the engine variables affecting NO_x emissions.

a.

b.

c.

ORIGIN OF INTERNAL
COMBUSTION ENGINE POLLUTANTS

UNIT 3

ANSWERS TO TEST

1. List and explain the origins of unburned HC emissions during normal combustion (main points).
 - a. Wall Quenching - Where a layer of air-fuel mixture close to the combustion chamber wall loses so much heat that it will not ignite through the combustion process.
 - b. Quench Areas - Small areas and cavities such as the inside of a spark plug - between top compression ring and piston top and around improperly fitted head gaskets, that are small and cool and the flame cannot burn into them. The actual "squish" area.
 - c. Combustion Chamber Deposits - Porous combustion chamber deposits absorb fuel and release it as an unburned vapor late in the power stroke or in the early exhaust stroke when the unburned fuel is exhausted to atmosphere.
2. List and explain the causes of incomplete combustion (main points).
 - a. Ignition System - Any worn or improperly adjusted component can cause a weak spark or no spark that results in the emission of unburned HC.
 - b. Low Air-Fuel Mixture Temperature - Results in poor mixing of the air and fuel and results in an uneven mixture that will not burn evenly resulting in the emission of unburned HC.
 - c. Rich or Lean Air-Fuel Mixtures - Too rich - not enough oxygen to allow burning of all the fuel, increased HC and CO emission. Too lean - may cause misfire because of fuel being too diluted with air to burn, increased HC emission.

- d. Excessive Exhaust Gas Dilution - During idle or deceleration (high manifold vacuum). Dilutes air-fuel mixture so incomplete combustion occurs resulting in increased HC emissions.
3. Origin of (CO) (main points).

Formed during combustion when there is not enough oxygen to convert the CO to CO₂.
 4. Origin of NO_x emissions (main points).

NO_x is formed at high temperatures during the combustion process.
 5. Engine variables affecting NO emissions (main points).
 - a. Ignition Timing - Advance timing, more fuel is burned before TDC resulting in high temperatures and high NO emissions. Retard Timing - More of the mixture is burned on power stroke, lower temperatures lower NO_x emissions.
 - b. Air-Fuel Mixture - Highest NO_x emissions are at 15:1 richer or leaner mixtures result in lower temperatures and lower NO emissions.
 - c. Exhaust Gas Dilution - Normally during idle and deceleration (high manifold vacuum) dilutes air-fuel mixture and results in lower combustion temperature, which results in lower NO emissions.

HEATED AIR INDUCTION SYSTEMS

UNIT 4

TERMINAL OBJECTIVE

After completion of this unit the student will be able to explain the purpose of the heated air induction systems and explain the purpose of the vacuum motor type and the thermostatically-controlled unit type components. The student will be able to visually inspect, disassemble, test and reassemble both systems.

This will be evidenced through demonstration and scoring 85% minimum on the unit test.

SPECIFIC OBJECTIVES

After completion of this unit the student will be able to:

1. Write the purpose of the intake air temperature control system.
2. Write the purpose of each of the components of the vacuum motor type system and temperature controlled unit type.
3. Identify the parts of both systems.
4. Explain in writing the operation of one or the other system from cold-start conditions to conditions at operating temperature.
5. Demonstrate the ability to:
 - a. Determine proper operation of vacuum motor system and thermostatically-controlled system.
 - b. Check vacuum diaphragm unit for leaks (vacuum motor system).
 - c. Check for proper operation of thermostat (thermostatically-controlled unit).
 - d. Check operation of vacuum override motor (thermostatically-controlled unit).

HEATED AIR INDUCTION SYSTEMS

UNIT 4

SUGGESTED ACTIVITIES

- I. Instructor
 - A. Provide students with objective sheet
 - B. Provide students with information sheets and job sheets
 - C. Make transparencies
 - D. Discuss terminal and specific objectives
 - E. Discuss information sheets
 - F. Demonstrate and discuss procedures outlined in job sheets
 - G. Give test
- II. Student
 - A. Read objective sheet
 - B. Study information sheets
 - C. Demonstrate the ability to accomplish the procedures outlined in the job sheets
 - D. Take test

INSTRUCTIONAL MATERIALS

- I. Included in this unit:
 - A. Objective sheet
 - B. Information sheets
 - C. Transparency masters
 - 4-TM-1 - Basic Air Flow
 - 4-TM-2 - Vacuum Motor System
 - 4-TM-3 - Temperature Controlled Unit

D. Job Sheets

1. Check for proper operation of vacuum motor system and thermostatically-controlled unit.
2. Check vacuum diaphragm unit for leaks.
3. Check for proper operation of thermostat.
4. Check operation of vacuum override unit.

E. Test

F. Answers to test

II. References

- A. Chrysler Corporation, 1973 Emission Controls, Chrysler Corp., P. O. Box 2119, Detroit, Mich. 48231, Attention: C. G. Palus.
- B. Glenn, Harold T. Glenn's Emission Control Systems, Chicago, Ill., Henry Regnery Co., (1972).
- C. Gargano Promotions. Vehicle Emission Control, 12824 West Seven Mile Road, Detroit, Mich. 48235, Gargano Promotions (1973).

HEATED AIR INDUCTION SYSTEMS

UNIT 4

INFORMATION SHEET

- I. PURPOSE OF THE HEATED AIR INDUCTION SYSTEM - To keep the air entering the carburetor at approximately 37.7°C(100°F) or higher. This allows leaner fuel mixtures which reduce HC emissions, gives better engine warmup characteristics and minimizes carburetor icing.
- II. TERMS, DEFINITIONS AND FUNCTIONS OF VACUUM MOTOR HEATED AIR INDUCTION SYSTEM - TM-1 and TM-2
 - A. Manifold Stove - A metal shroud around the exhaust manifold that directs air flow over the exhaust manifold to preheat it.
 - B. Hot Air Pipe - Connects manifold stove to snorkel tube on air cleaner just below the damper assembly.
 - C. Damper Assembly - Connected to vacuum diaphragm by linkage which positions it to direct preheated air, or engine compartment air to carburetor.
 - D. Vacuum Diaphragm Unit - Controls damper assembly. Actuated by spring pressure and manifold vacuum.
 - E. Temperature Sensor - Senses incoming air temperature by means of a temperature sensitive spring. The position of the spring operates a small valve that determines if vacuum is applied to vacuum diaphragm or if it is vented.
- III. TERMS, DEFINITIONS AND FUNCTIONS OF THERMOSTATICALLY-OPERATED HEATED AIR INDUCTION SYSTEM - TM-3
 - A. Manifold stove and hot air pipe are the same.
 - B. Thermostat - Senses air temperature and expands as temperature increases to operate valve plate.

- C. Valve Plate - Operated by the thermostat and determines if air reaching carburetor is preheated or engine compartment air.
- D. Vacuum Override Motor - Allows increased intake air during cold acceleration. A decrease in intake manifold vacuum allows the vacuum motor to override the thermostatic control, allowing both preheated and engine compartment air to enter the carburetor.
- IV. EXPLANATION OF VACUUM MOTOR SYSTEM OPERATION - When engine compartment air temperature is less than $37.7^{\circ}\text{C}(100^{\circ}\text{F})$ and the engine is started the following sequence occurs:
- (1) The temperature sensor spring prevents air bleed (venting) therefore manifold vacuum is directed to vacuum diaphragm unit.
 - (2) Vacuum in the vacuum diaphragm unit overcomes spring tension. This action through linkage, positions the damper assembly to prevent engine compartment air from entering the carburetor.
 - (3) Air is drawn into the manifold stove and is preheated by the exhaust manifold. This heated air is drawn through the hot air pipe into the carburetor.
 - (4) As the temperature in the air cleaner assembly reaches approximately $37.7^{\circ}\text{C}(100^{\circ}\text{F})$ the spring in the temperature sensor unit allows some air to be bled in. This reduces vacuum at the vacuum diaphragm.
 - (5) As vacuum is reduced in the vacuum diaphragm, the spring tension forces down the linkage and the damper assembly. This allows some engine compartment air to enter the air cleaner and mix with the preheated air.
 - (6) When air temperature at the temperature sensor is greater than $37.7^{\circ}\text{C}(100^{\circ}\text{F})$, the spring in the temperature sensor allows full air bleed. This reduces vacuum in the vacuum diaphragm unit to such a low value that the spring completely closes the damper assembly allowing only engine compartment air to enter the carburetor.

V. EXPLANATION OF THERMOSTATICALLY-CONTROLLED SYSTEM OPERATION - When engine compartment temperature is below 37.7°C (100°F) and the engine is started, the following occurs:

- (1) The thermostatic control is in a contracted position. This position lifts the valve plate to block off engine compartment air and allows preheated air to be drawn into the carburetor from the manifold stove and hot air pipe.
- (2) As the air temperature passing over the thermostat increases, the thermostat begins to expand. This starts to lower the valve plate allowing some engine compartment air to mix with the preheated air.
- (3) When the air temperature is 37.7°C (100°F) or greater, the thermostat is fully extended. This closes off the preheated air and allows engine compartment air to enter the carburetor.
- (4) During cold acceleration, a drop in manifold vacuum to the vacuum override motor allows the spring in vacuum override motor to reposition the valve plate (overrides thermostatic control) to allow engine compartment and preheated air to mix.

BASIC AIR FLOW

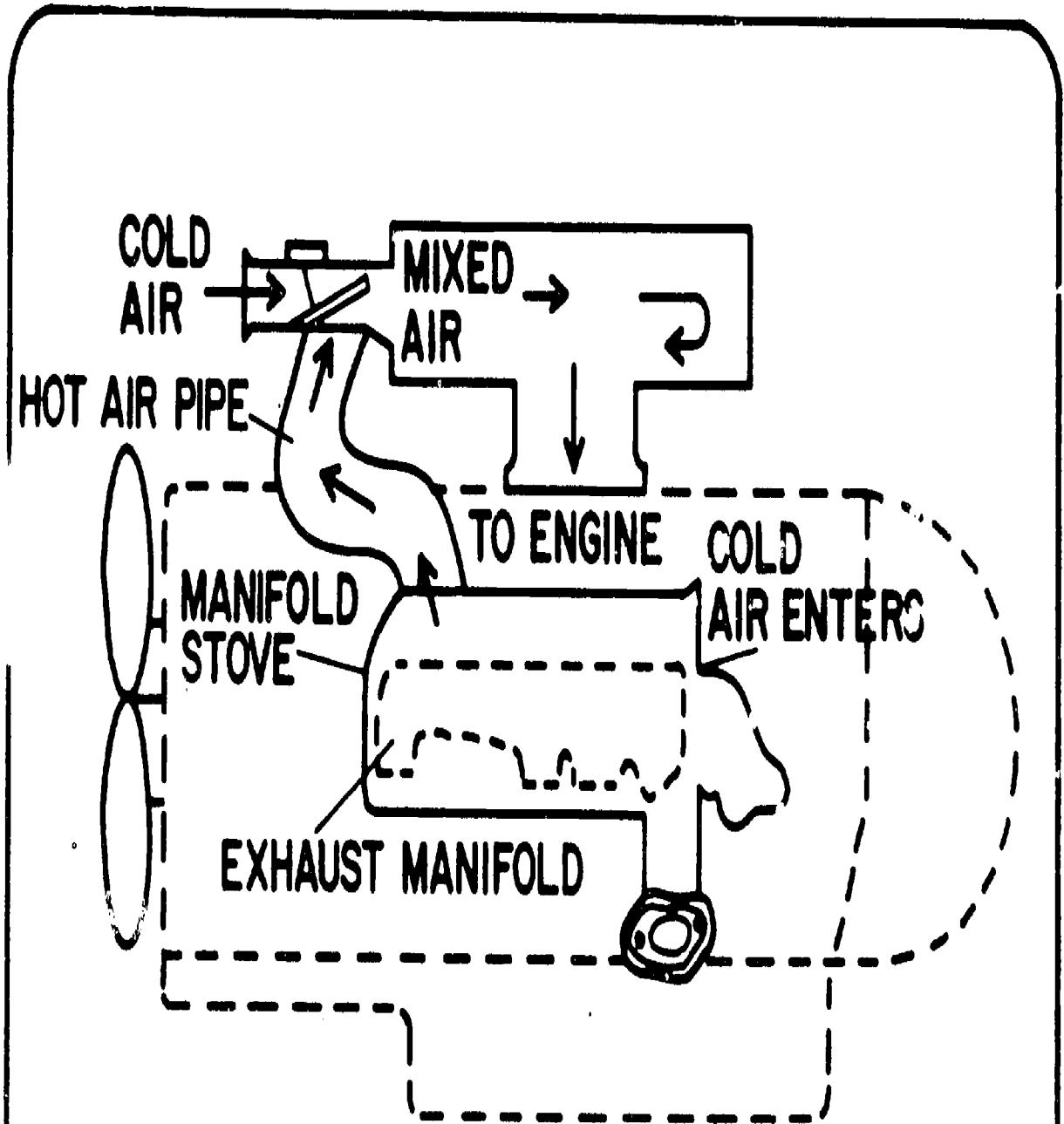

**AIR HEATED BY MANIFOLD HEATED
AIR INDUCTION REDUCES HC & CO**

VACUUM MOTOR SYSTEM

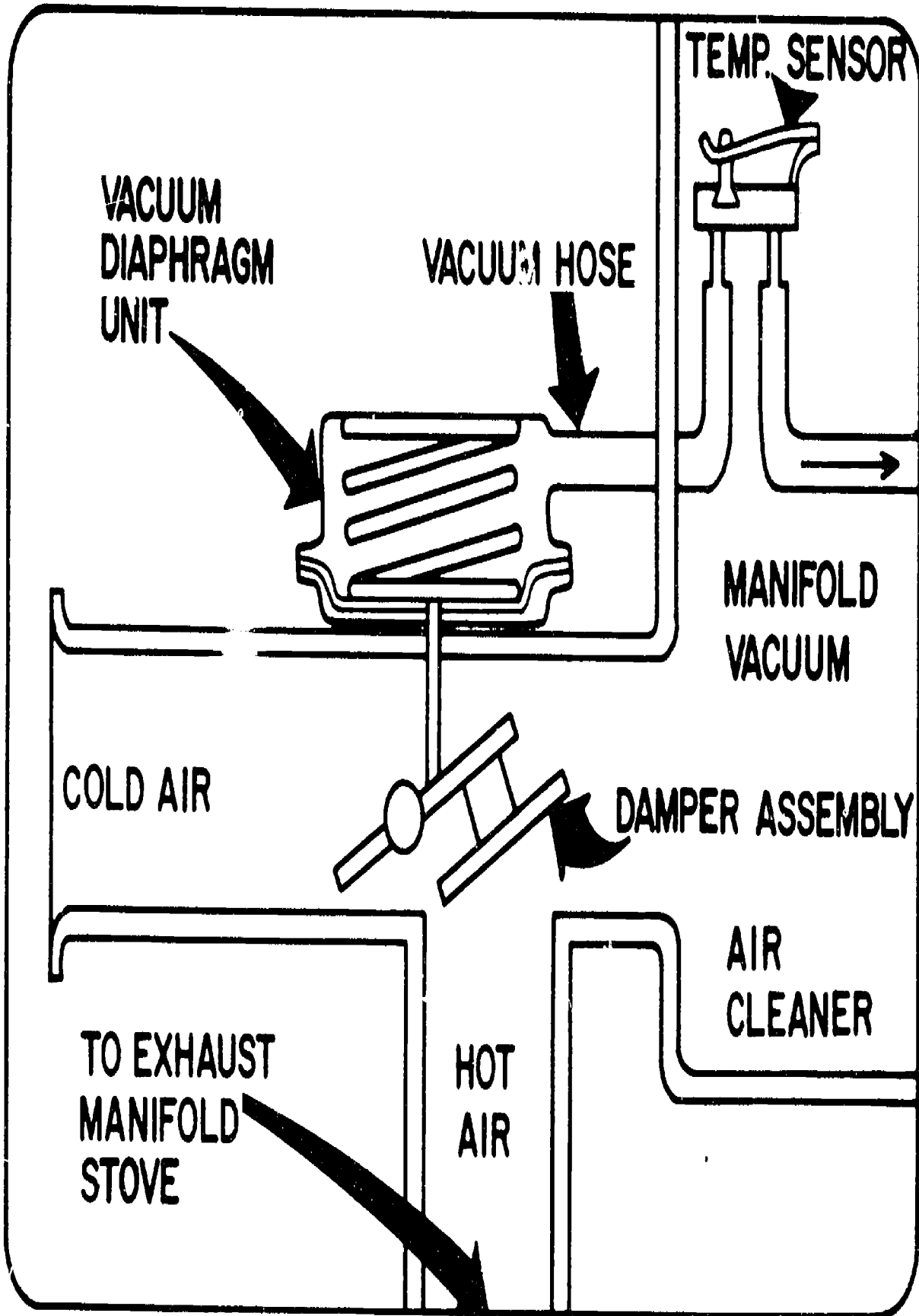

TEMPERATURE CONTROLLED UNIT

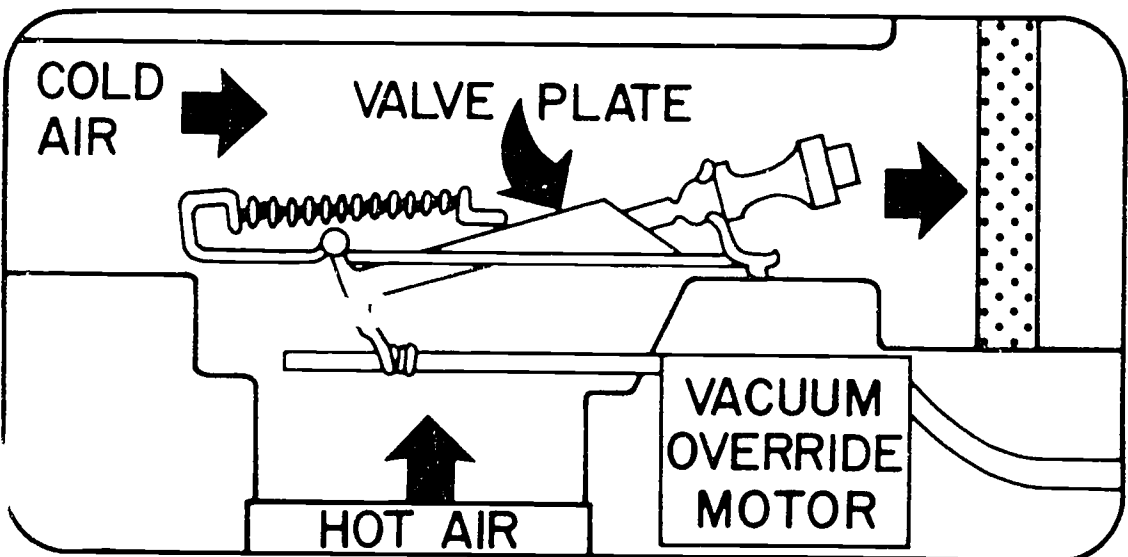
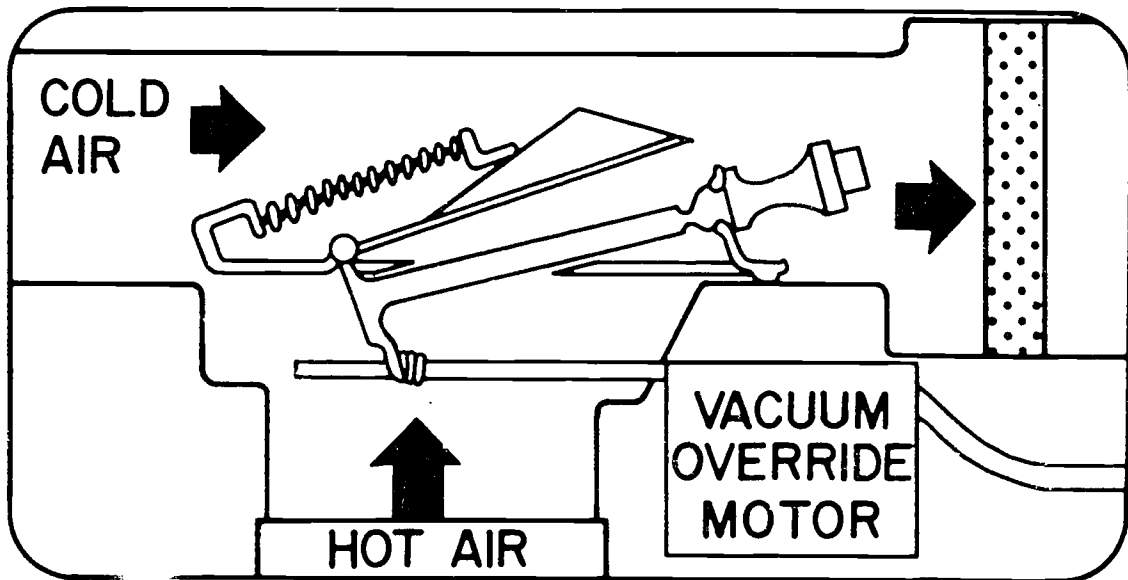
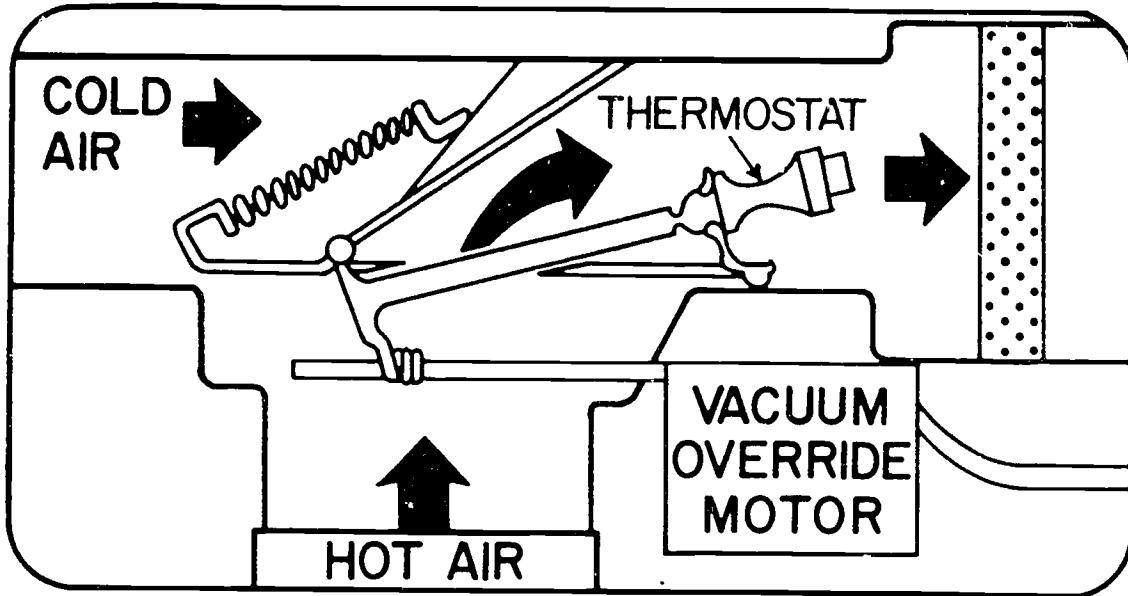

HEATED AIR INDUCTION SYSTEMS

UNIT 4

JOB SHEET #1 - DETERMINE PROPER OPERATION OF VACUUM MOTOR SYSTEM AND
THERMOSTATICALLY-CONTROLLED SYSTEM

I. Tools required

Thermometer

II. Procedure

- A. Check engine compartment temperature (should be less than 37.7°C (100°F).
- B. Engine should be cold.
- C. Insure all vacuum hoses are tight and in good condition.
- D. Insure hot air pipe is securely attached to manifold stove and air cleaner.
- E. Start engine.
- F. Damper assembly valve plate should be up (heat on position).
- G. Warm up engine.
- H. Check temperature at snorkel inlet or temperature sensor. If 40.1°C(105°F) or higher; damper assembly (valve plate) should be down (heat off position).

NOTE: These are BASIC PROCEDURES. Check the proper manufacturers technical or shop manual for exact procedures and settings for each make and model.

JOB SHEET #2 - CHECK VACUUM DIAPHRAGM UNIT FOR LEAKS

I. Tools required

- A. Vacuum pump
- B. Vacuum gauge
- C. Bleed valve
- D. Shutoff valve

II. Procedure

- A. Remove air cleaner assembly.
- B. Attach vacuum pump and gauge to vacuum diaphragm unit.
- C. Start pump.
- D. Close down bleed valve until vacuum shows 20" Hg.
- E. Close shutoff valve.
- F. Turn off pump.
- G. Vacuum diaphragm unit should hold 20" Hg for 5 minutes.
- H. Release vacuum.
- I. Start pump.
- J. With bleed valve build vacuum slowly and observe for:
 - 1. Valve plate should begin to lift at not less than 5" Hg.
 - 2. Valve plate should be full up with no more than 9" Hg.

NOTE: These are BASIC PROCEDURES. Check the proper manufacturers technical or shop manual for exact procedures and settings for each make and model.

JOB SHEET #3 - CHECK FOR PROPER OPERATION OF THERMOSTAT

I. Tools and Equipment

- A. Thermometer
- B. Large Pan
- C. External Source of Heat

II. Procedure

- A. Remove air cleaner assembly.
- B. Remove air filter element -

NOTE: If temperature is less than 37.7°C (100°F) valve plate should be in the heat on position.

- C. Remove duct (snorkel) and valve assembly.
- D. Fill large pan with water.
- E. Immerse in water.
- F. Raise water temperature to 37.7°C (100°F) -

NOTE: Soak unit at this temperature for 5 minutes to stabilize temperature.

- G. Increase water temperature to 56.1°C (135°F) (valve plate should move to heat off position.
- H. If valve plate does not move check for misalignment and binding and correct as necessary.
- I. If valve plate does not operate properly and no binding is present, replace duct and valve assembly.

NOTE: These are BASIC PROCEDURES. Check the proper manufacturers technical or shop manual for exact procedures and settings for each make and model.

JOB SHEET #4 - CHECK OPERATION OF VACUUM OVERRIDE MOTOR

I. Tools and Equipment

Vacuum gauge

II. Procedure

- A. Engine should be cold.
- B. Disconnect hose from vacuum override unit.
- C. Connect vacuum gauge to hose.
- D. Start engine.
- E. At idle vacuum should be 15" or greater (if less than 15" check for leaks in hose or at fitting on manifold).
- F. Check to see if damper is partly open to admit both engine compartment air and heated air.
- G. Remove vacuum gauge.
- H. Connect vacuum hose to vacuum override motor.
- I. Check to see if damper moves to heat on position.
- J. If damper does move to heat on position, the vacuum override motor should be replaced.

NOTE: These are BASIC PROCEDURES. Check the proper manufacturers technical or shop manual for exact procedures and settings for each make and model.

HEATED AIR INDUCTION SYSTEMS

UNIT 4

T E S T

1. What is the purpose of the intake air temperature control system?

2. Write the purpose of each of the components of the vacuum motor type system and temperature controlled unit type.

Vacuum motor type

a.

b.

c.

d.

e.

2. (Continued)

Temperature controlled type

a.

b.

c.

d.

3. Identify the parts of the vacuum motor system.

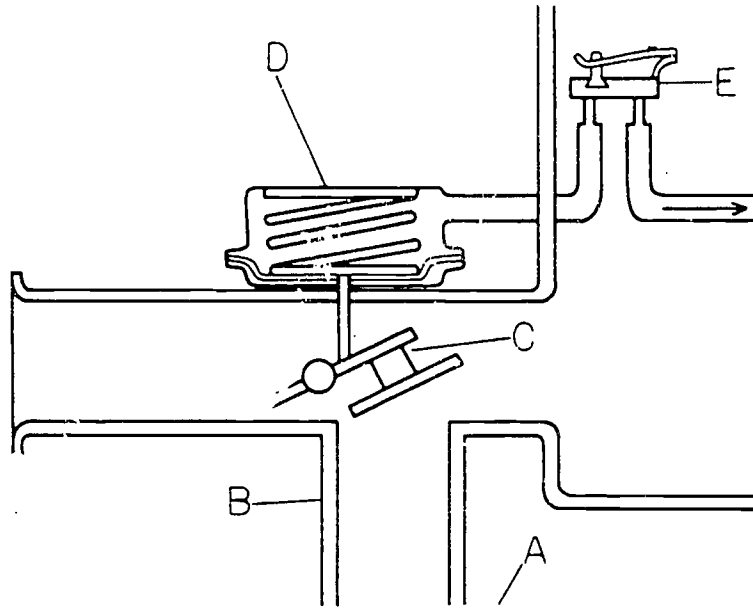

a.

b.

c.

d.

e.

3. (Continued)

Identify the parts of the temperature controlled system.

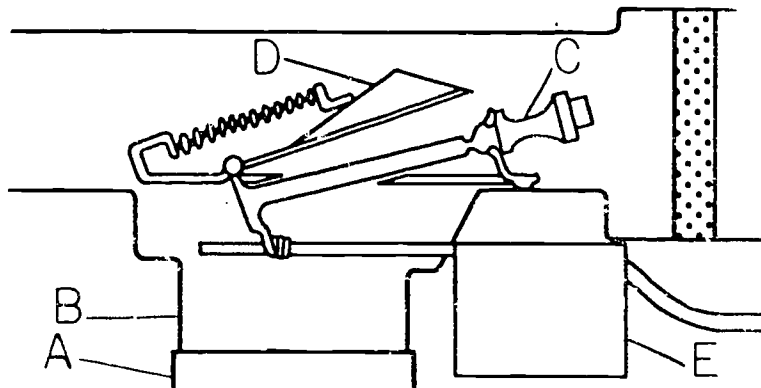

a.

b.

c.

d.

e.

4. Explain in writing the operation of one or the other system from cold-start conditions to conditions at operating temperature.

5. The student should demonstrate the ability to perform the following jobs to the satisfaction of the instructor:
- a. Determine proper operation of vacuum motor system and thermostatically-controlled system.
 - b. Check vacuum diaphragm unit for leaks (vacuum motor system).
 - c. Check for proper operation of thermostat (thermostatically-controlled unit).
 - d. Check operation of vacuum override motor (thermostatically-controlled unit).

HEATED AIR INDUCTION SYSTEMS

UNIT 4

ANSWERS TO TEST

1. What is the purpose of the intake air temperature control system?
To keep the air entering the carburetor at approximately 37.7°C (100°F) or higher. This allows leaner fuel mixtures which reduce HC emissions, gives better engine warmup characteristics and minimizes carburetor icing.

2. Write the purpose of each of the components of the vacuum motor type system and temperature controlled unit type.

Vacuum motor type

- a. Manifold Stove - A metal shroud around the exhaust manifold that directs air flow over the exhaust manifold to preheat it.
- b. Hot Air Pipe - Connects manifold stove to snorkel tube on air cleaner just below the damper assembly.
- c. Damper Assembly - Connected to vacuum diaphragm by linkage which positions it to direct preheated air, or engine compartment air to carburetor.
- d. Vacuum Diaphragm Unit - Controls damper assembly. Actuated by spring pressure and manifold vacuum.
- e. Temperature Sensor - Senses incoming air temperature by means of a temperature sensitive spring. The position of the spring operates a small valve that determines if vacuum is applied to vacuum diaphragm or if it is vented.

2. (Continued)

Temperature controlled type

- a. Manifold stove and hot air pipe are the same.
 - b. Thermostat - Senses air temperature and expands as temperature increases to operate valve plate.
 - c. Valve Plate - Operated by the thermostat and determines if air reaching carburetor is preheated or engine compartment air.
 - d. Vacuum Override Motor - Allows increased intake air during cold acceleration. A decrease in intake manifold vacuum allows the vacuum motor to override the thermostatic control, allowing both preheated and engine compartment air to enter the carburetor.
3. Identify the parts of both systems.

Vacuum motor type

- a. Manifold stove
- b. Hot air pipe
Damper assembly
- c. Vacuum diaphragm unit
- e. Temperature sensor

Temperature controlled unit

- a. Manifold stove
- b. Hot air pipe
- c. Thermostat
- d. Valve plate
- e. Vacuum override motor

4. Explain in writing the operation of one or the other systems from cold-start conditions to conditions at operating temperature.

Vacuum motor system operation

- a. The temperature sensor spring prevents air bleed (venting) therefore manifold vacuum is directed to vacuum diaphragm unit.
- b. Vacuum in the vacuum diaphragm unit overcomes spring tension. This action through linkage, positions the damper assembly to prevent engine compartment air from entering the carburetor.
- c. Air is drawn into the manifold stove and is preheated by the exhaust manifold. This heated air is drawn through the hot air pipe into the carburetor.
- d. As the temperature in the air cleaner assembly reaches approximately 37°C(100°F) the spring in the temperature sensor unit allows some air to be bled in. This reduces vacuum at the vacuum diaphragm.
- e. As vacuum is reduced in the vacuum diaphragm, the spring tension forces down the linkage and the damper assembly. This allows some engine compartment air to enter the air cleaner and mix with the preheated air.
- f. When air temperature at the temperature sensor is greater than 37.7°C(100°F), the spring in the temperature sensor allows full air bleed. This reduces vacuum in the vacuum diaphragm unit to such a low value that the spring completely closes the damper assembly allowing only engine compartment air to enter the carburetor.

4. (Continued)

Thermostatically-controlled system operation

- a. The thermostatic control is in a contracted position. This position lifts the valve plate to block off engine compartment air and allows preheated air to be drawn into the carburetor from the manifold stove and hot air pipe.
- b. As the air temperature passing over the thermostat increases, the thermostat begins to expand. This starts to lower the valve plate allowing some engine compartment air to mix with the preheated air.
- c. When the air temperature is 37.7°C(100°F) or greater, the thermostat is fully extended. This closes off the preheated air and allows engine compartment air to enter the carburetor.
- d. During cold acceleration, a drop in manifold vacuum to the vacuum override motor allows the spring in vacuum override motor to reposition the valve plate (overrides thermostatic control) to allow engine compartment and preheated air to mix.

EVAPORATIVE EMISSIONS CONTROL SYSTEM

UNIT 5

TERMINAL OBJECTIVE

After completion of this unit the student will be able to identify the components and explain the operation of a basic evaporative emission control system. The student will be able to visually inspect, test, and service the evaporative emission control system.

This will be evidenced through demonstration and scoring 85% minimum on the unit test.

SPECIFIC OBJECTIVES

After completion of this unit the student will be able to:

1. Write the purpose of the evaporative emission control system.
2. Identify the components of a basic evaporative emission control system.
3. Explain the function of each component.
4. Explain the operation of the basic system.
5. List the methods of carburetor vapor control.
6. Demonstrate the ability to:
 - a. Change the charcoal cannister filter.
 - b. Test the fuel tank filler cap.

EVAPORATIVE EMISSIONS CONTROL SYSTEM

UNIT 5

SUGGESTED ACTIVITIES

- I. Instructor
 - A. Provide students with objective sheet
 - B. Provide students with information sheets and job sheets
 - C. Make transparencies
 - D. Discuss terminal and specific objectives
 - E. Discuss information sheets
 - F. Demonstrate and discuss procedures outlined in job sheets
 - G. Give test
- II. Student
 - A. Read objective sheet
 - B. Study information sheets
 - C. Demonstrate ability to accomplish the procedures
 - D. Take test

INSTRUCTIONAL MATERIALS

- I. Included in this unit:
 - A. Objective sheet
 - B. Information sheet
 - C. Transparency masters
 - 5-TM-1 - Evaporative Emissions Control System
 - 5-TM-2 - Fuel Tank with Thermal Expansion Valve
 - 5-TM-3 - Fuel Tank Filler Cap
 - 5-TM-4 - Vapor Liquid Separator
 - 5-TM-5 - Charcoal Canister
 - 5-TM-6 - Charcoal Canister Purging Methods
 - 5-TM-6A - Purge Air Flow
 - 5-TM-6B - Purge Valve
 - 5-TM-6C - Orifice at Purge

D. Job Sheets

1. Replace charcoal canister filter
2. Test the fuel tank filler cap

E. Test

F. Answers to test

II. References

- A. 1973 Chevrolet Service Manual (contact local dealer).
- B. Chrysler Corporation, 1973 Emission Controls, Chrysler Corp.,
P. O. Box 2119, Detroit, Mich. 48231, Attention: C. G. Palus.
- C. Glenn, Harold T. Glenn's Emission Control Systems, Chicago, Illinois,
Henry Regnery Company, (1972).
- D. Gargano Promotions. Vehicle Emission Control, 12824 West Seven
Mile Road, Detroit, Mich. 48235, Gargano Promotions, (1974).

EVAPORATIVE EMISSIONS CONTROL SYSTEM

UNIT 5

INFORMATION SHEET

- I. PURPOSE OF THE EVAPORATIVE EMISSION CONTROL SYSTEM - To control the release of hydrocarbons (HC) to the atmosphere that results from fuel vapors escaping from fuel tanks and carburetor vents
- II. TERMS, DEFINITIONS AND FUNCTIONS OF EVAPORATIVE EMISSION CONTROL SYSTEM. TM-1
 - A. Fuel Tank - TM-2 - A sealed unit for storing the fuel that has a build-in air space (approximately 11% of tank volume) to allow for fuel expansion due to temperature increases.
 - B. Fuel Tank Filler Cap - TM-3 - Seals the fuel tank and acts as a pressure vacuum relief valve to protect the fuel tank from excessive pressure or vacuum.
 - C. Vapor Vent Lines - TM-1 - Allow vapors to escape from the fuel tank and pass to a vapor-liquid separator.
 - D. Vapor-Liquid Separator - TM-4 - Prevents passage of liquid fuel to the carbon canister by means of either a float valve that seals the outlet when liquid fuel enters or by means of standpipes. The standpipes are set at different heights to allow liquid fuel to return to the tank and only vapors to escape.
 - E. Charcoal Canister - TM-5 - Contains activated charcoal that traps and stores fuel vapors. When the canister is purged with fresh air the trapped fuel vapors are removed and vented to the carburetor.
 - F. Purge Line - Allows passage of fuel vapor from the charcoal canister to the carburetor or air cleaner when the engine is running.

G. Carburetor Vapor Control - The following are some of the methods used to control carburetor vapors:

1. External carburetor vents are being eliminated.
2. Use of lower temperature thermostats to reduce under hood temperatures.
3. Reduction of carburetor fuel bowl temperatures by:
 - a. Insulating washers on carburetor hold-down studs.
 - b. Use of insulating gaskets and aluminum radiant heat shields.
4. Venting carburetor fuel bowls to the charcoal canister.

III. EXPLANATION OF EVAPORATIVE EMISSIONS CONTROL SYSTEM OPERATION - When the fuel tank is full and subjected to changes in temperature the following will occur:

- (1) As the fuel becomes warm it expands and at the same time releases fuel vapors.
- (2) The expansion is taken up in the design of the fuel tank which prevents filling approximately 11 of the tank's volume.
- (3) The vapors that are released, pass through the vent line to the vapor-liquid separator which allows the vapors to pass through but will prevent any liquid fuel from passing.
- (4) The vapors travel to the activated charcoal canister where they are trapped and stored.
- (5) When the engine is started, the canister is purged via a vent line that runs to the carburetor or air cleaner.

NOTE: There are different methods used to purge the charcoal canister and FIG. 15, 16, 17, 18 show three of these systems.

- (6) As fuel is consumed, a partial vacuum develops in the fuel tank. The filler cap, which acts as a relief valve, opens when fuel tank vacuum pressure reaches approximately .5 to 1 psi to allow air into equalize the pressure and prevent fuel tank damage.

EVAPORATIVE EMISSIONS CONTROL SYSTEM

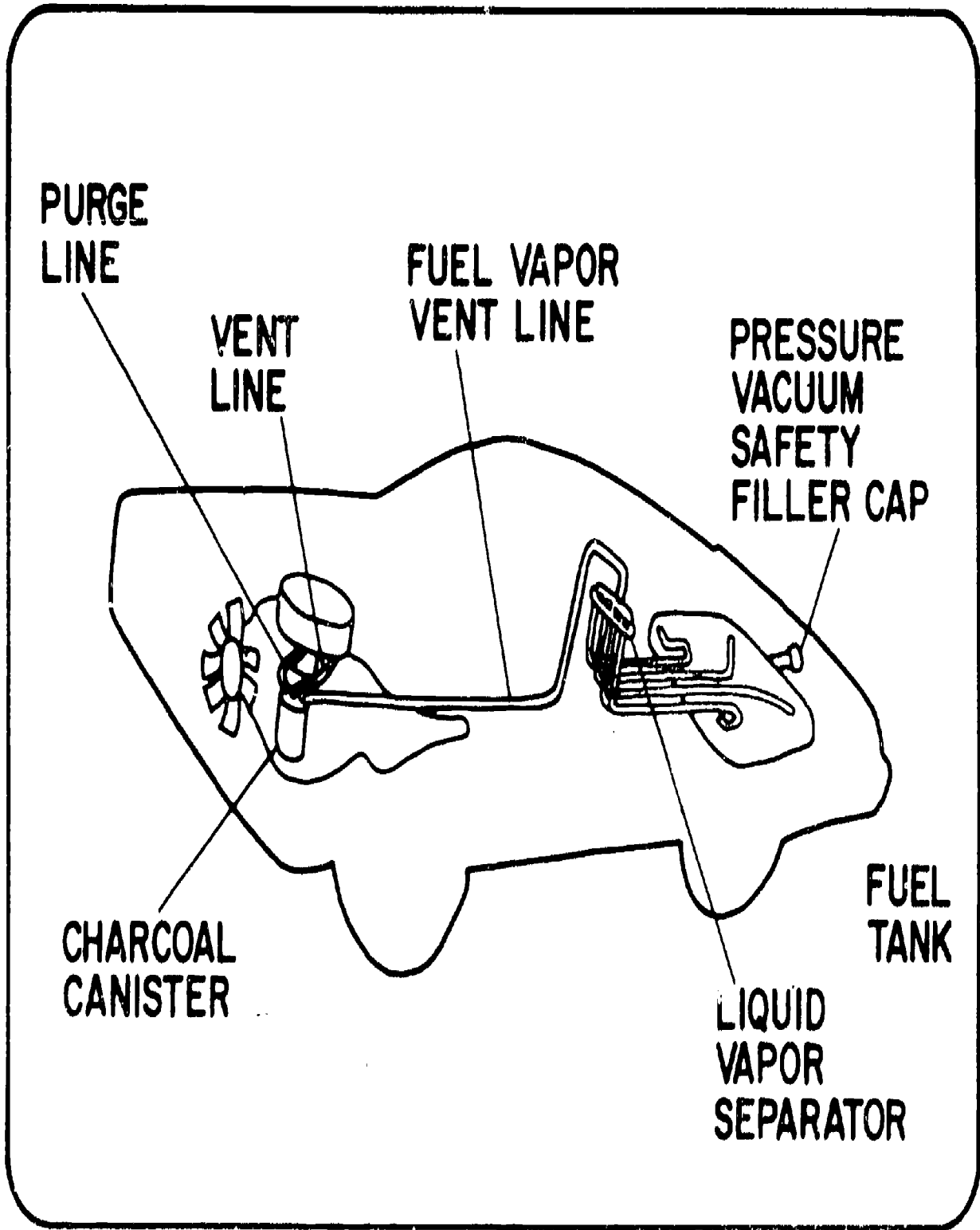

FUEL TANK WITH THERMAL EXPANSION VOLUME

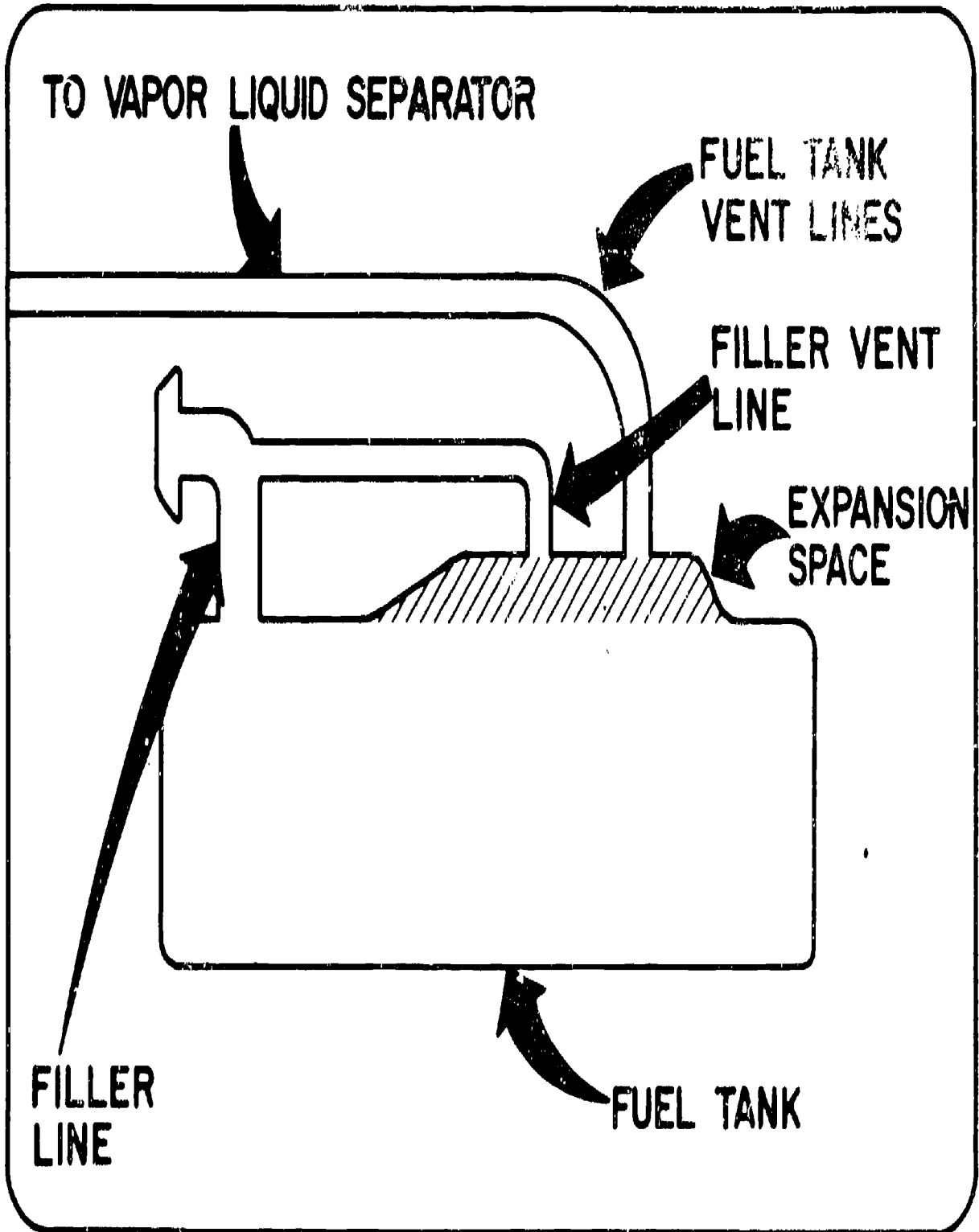

TM

PRESSURE - VACUUM RELIEF FILLER CAP

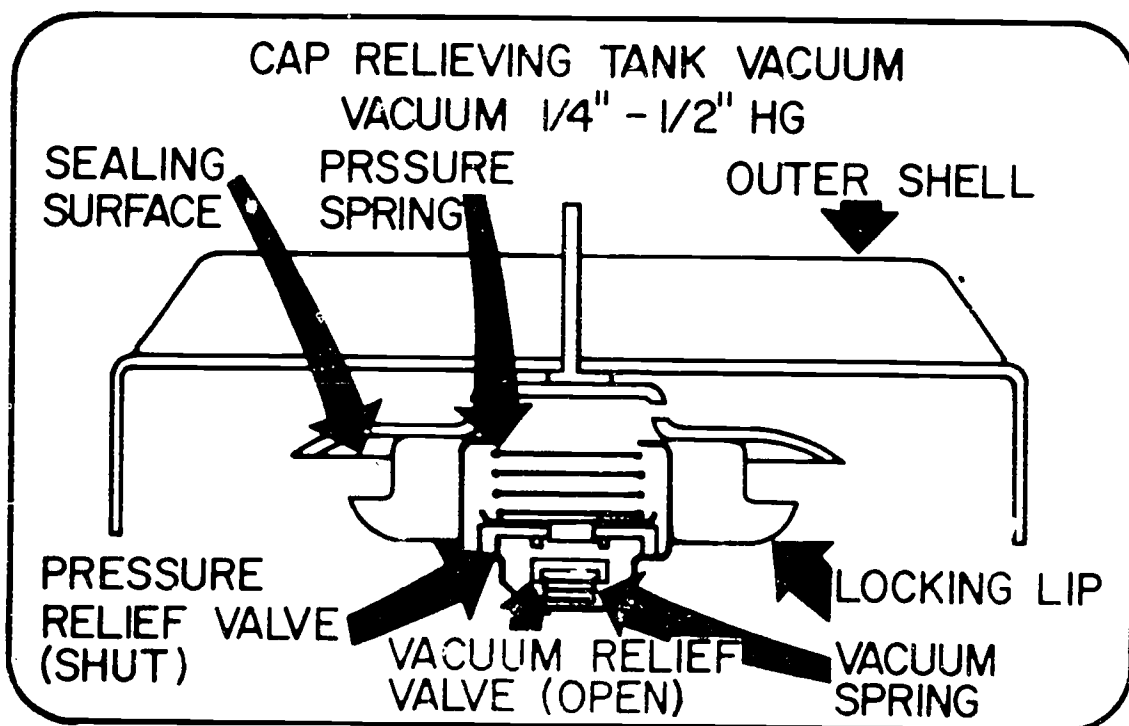
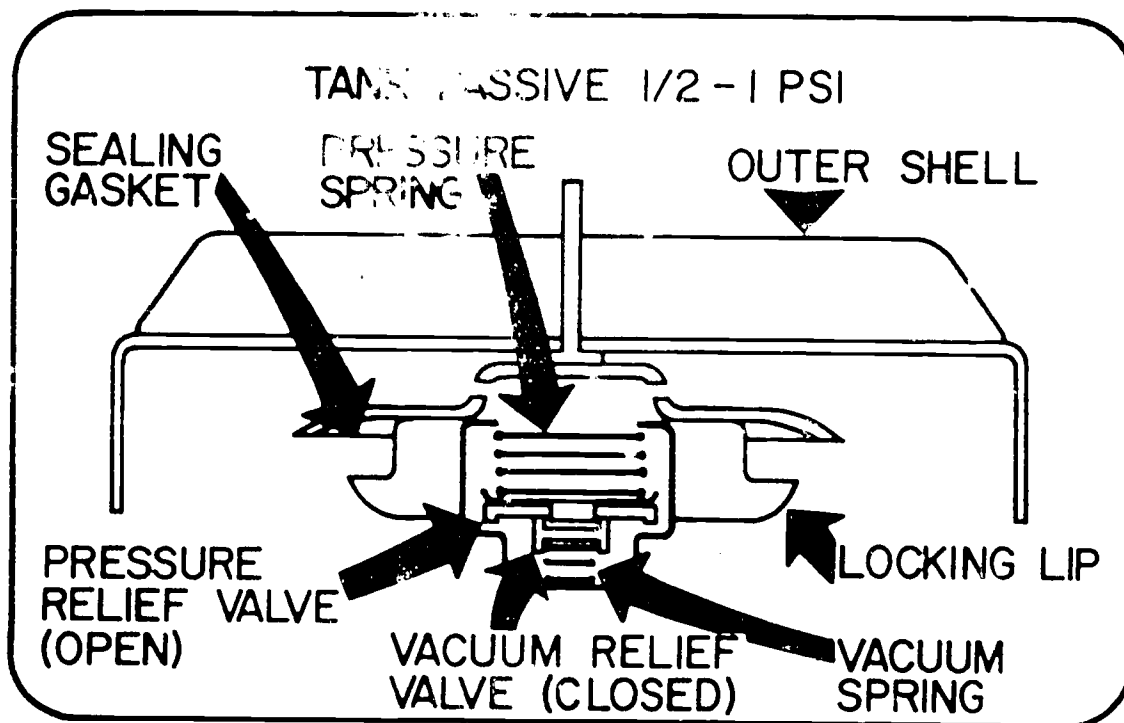

VAPOR LIQUID SEPARATOR

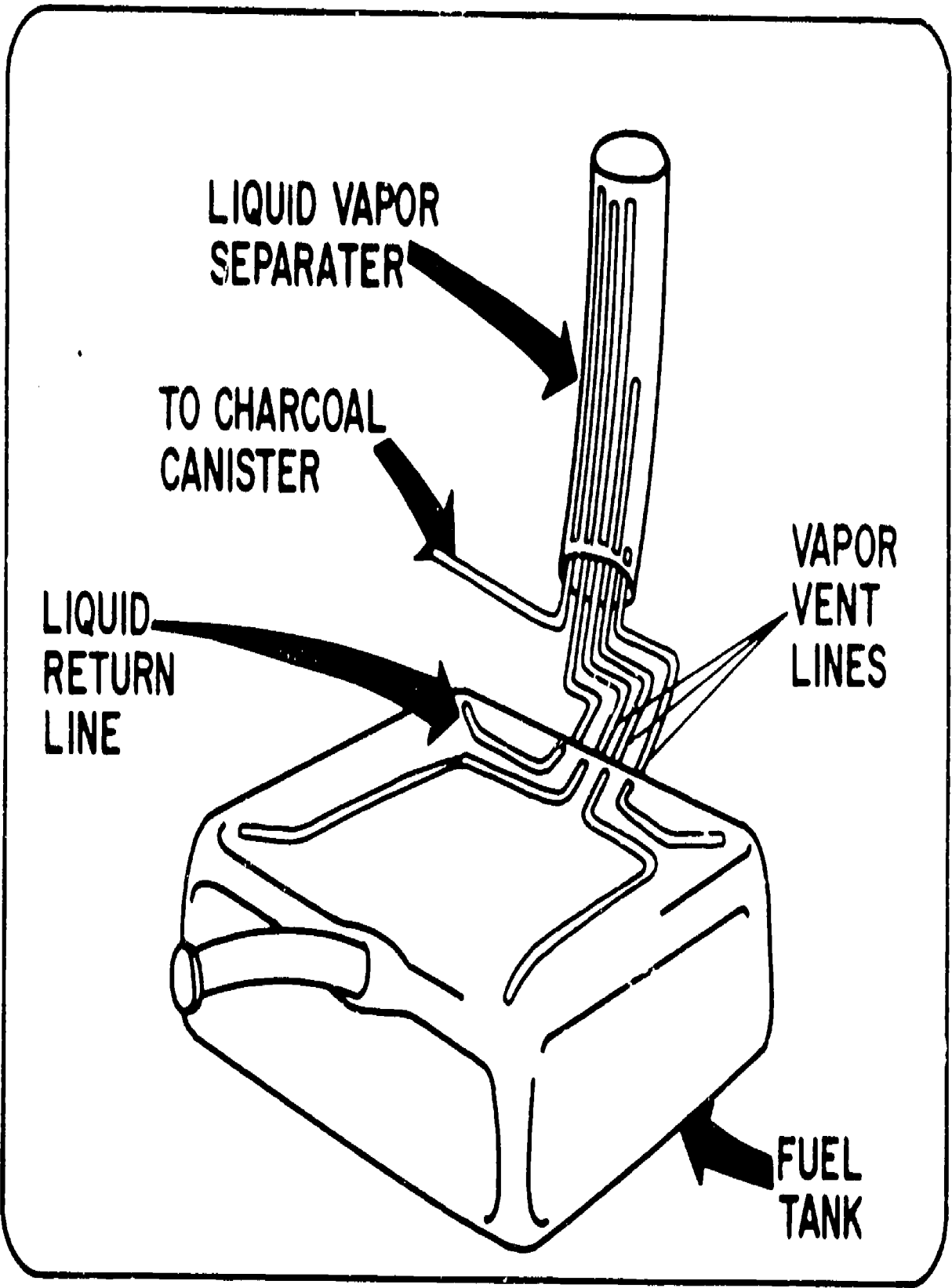

CHARCOAL CANISTER

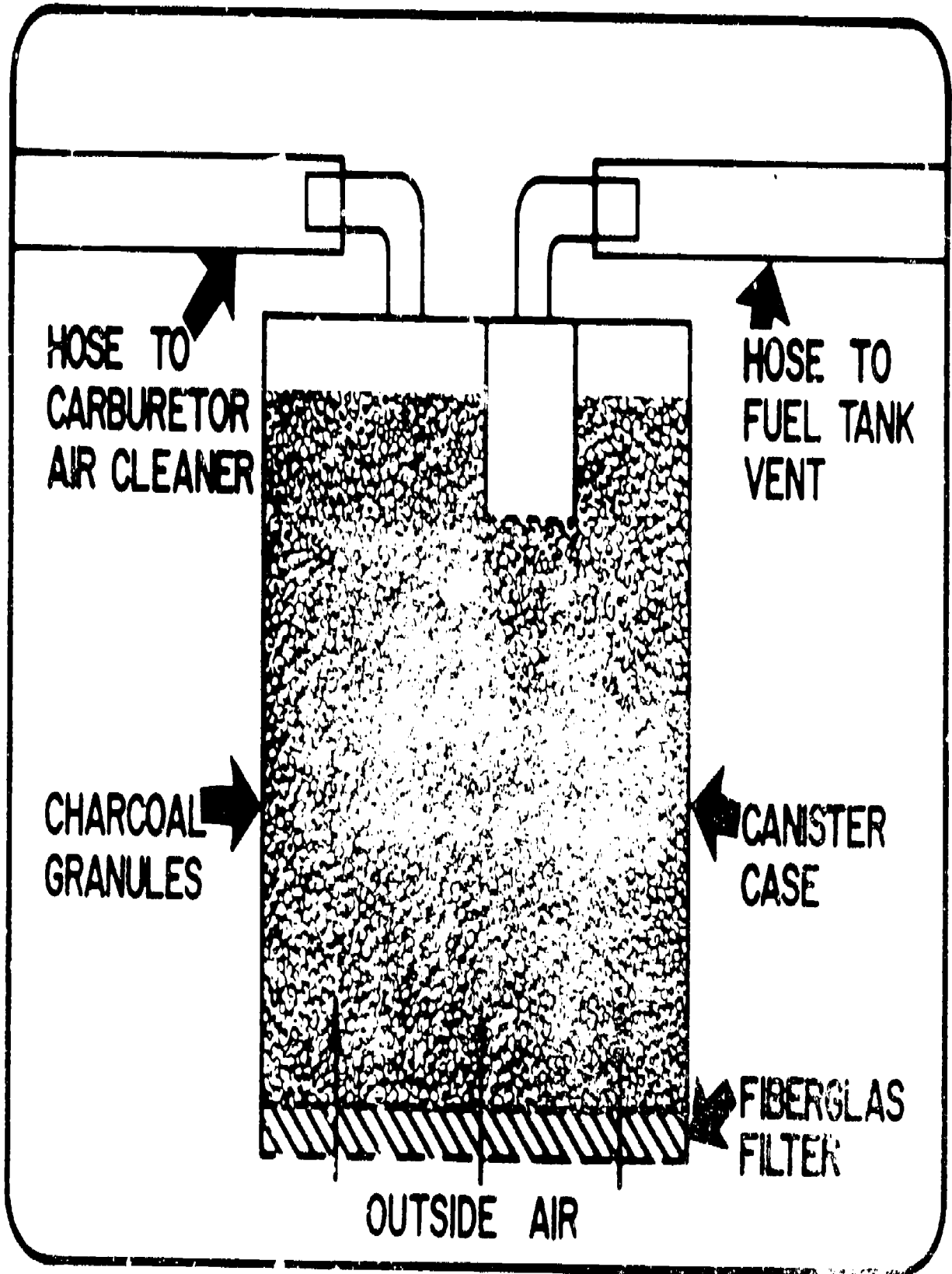

CHARCOAL CANISTER PURGING METHODS

PURGE AIR FLOW (AIR CLEANER METHOD)

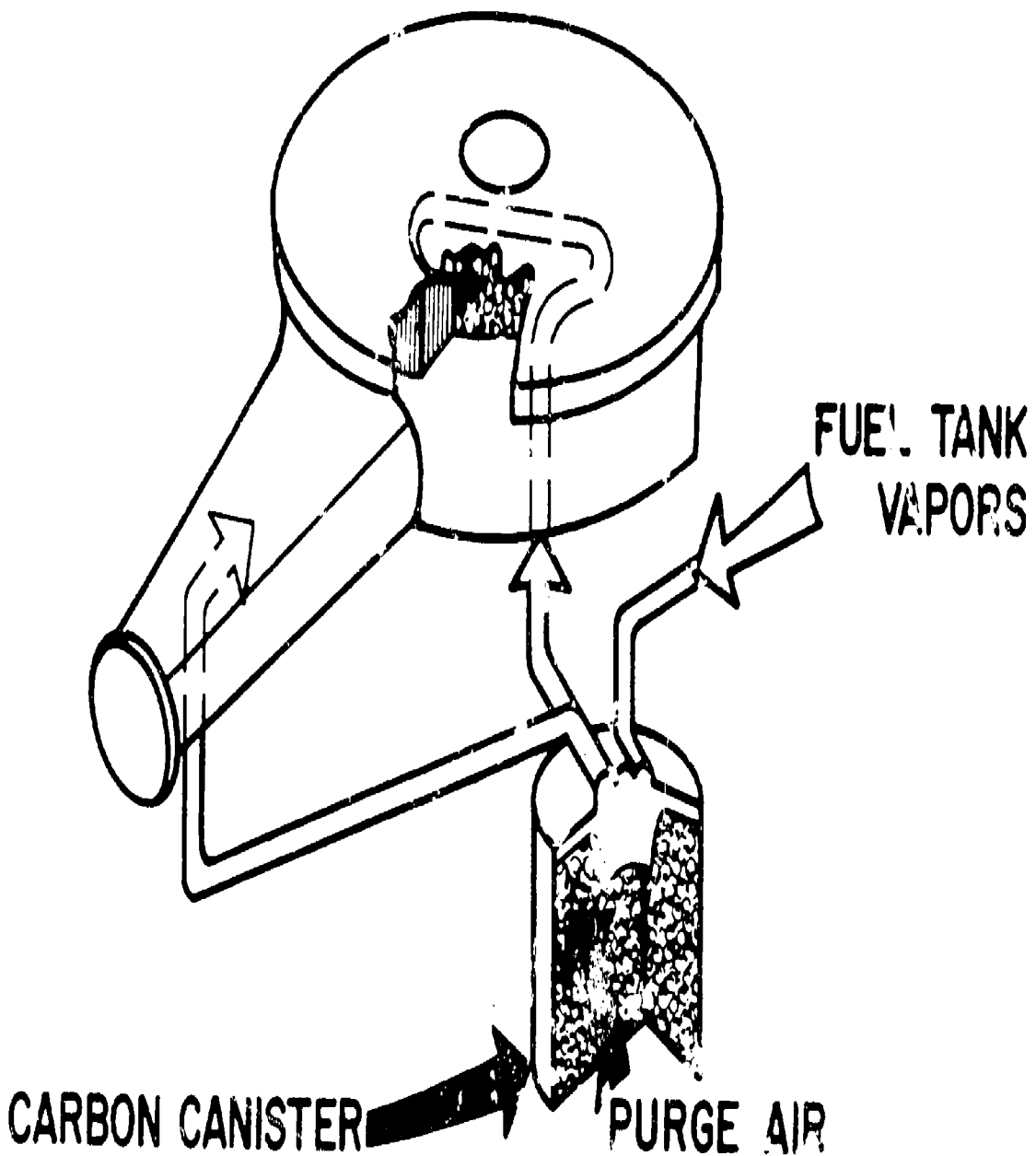

CHARCOAL CANISTER PURGING METHODS

PURGE VALVE, HEAT SHIELD, AND CARBURETOR VENT

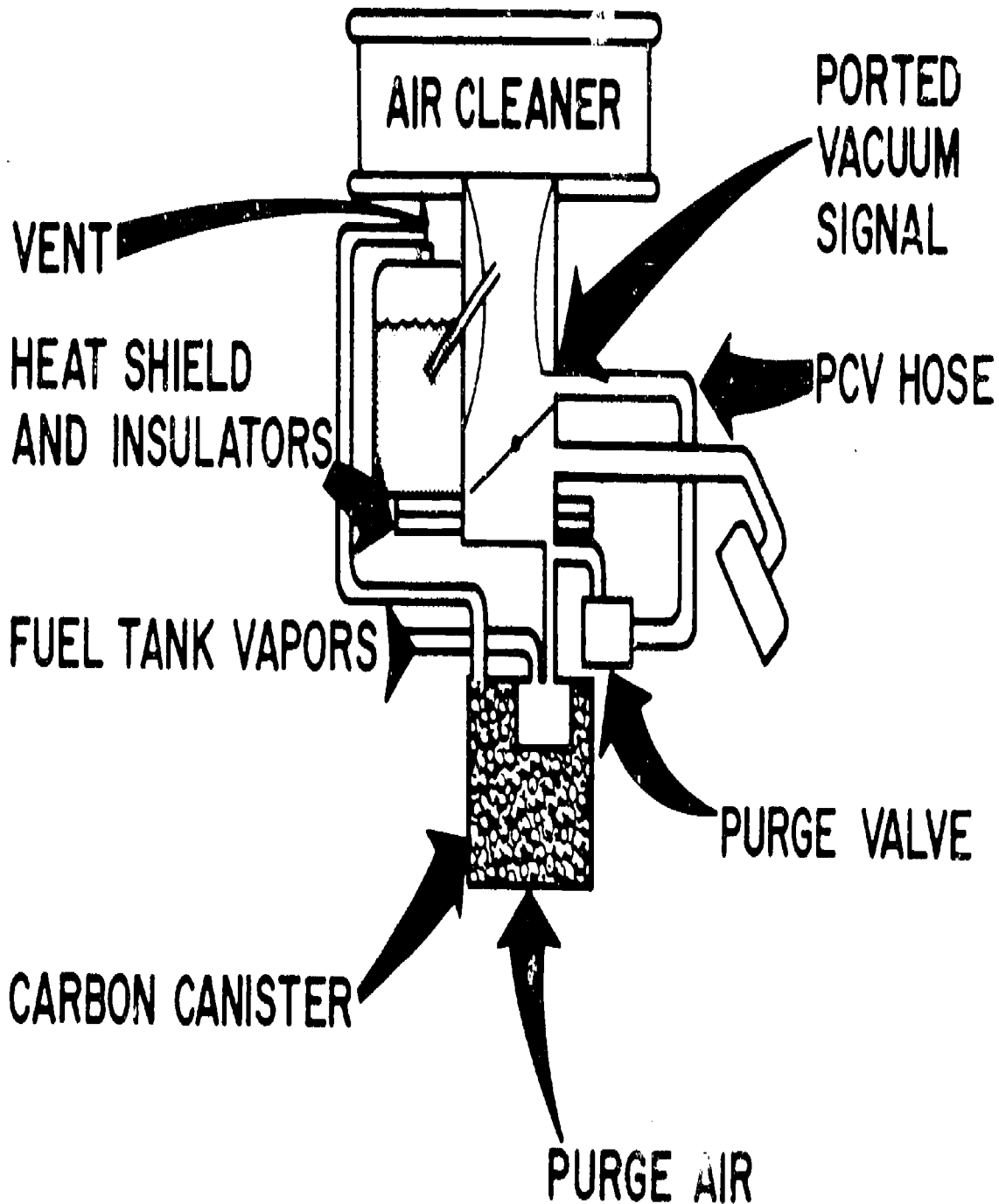

CHARCOAL CANISTER PURGING METHODS

CONSTANT PURGE METHOD

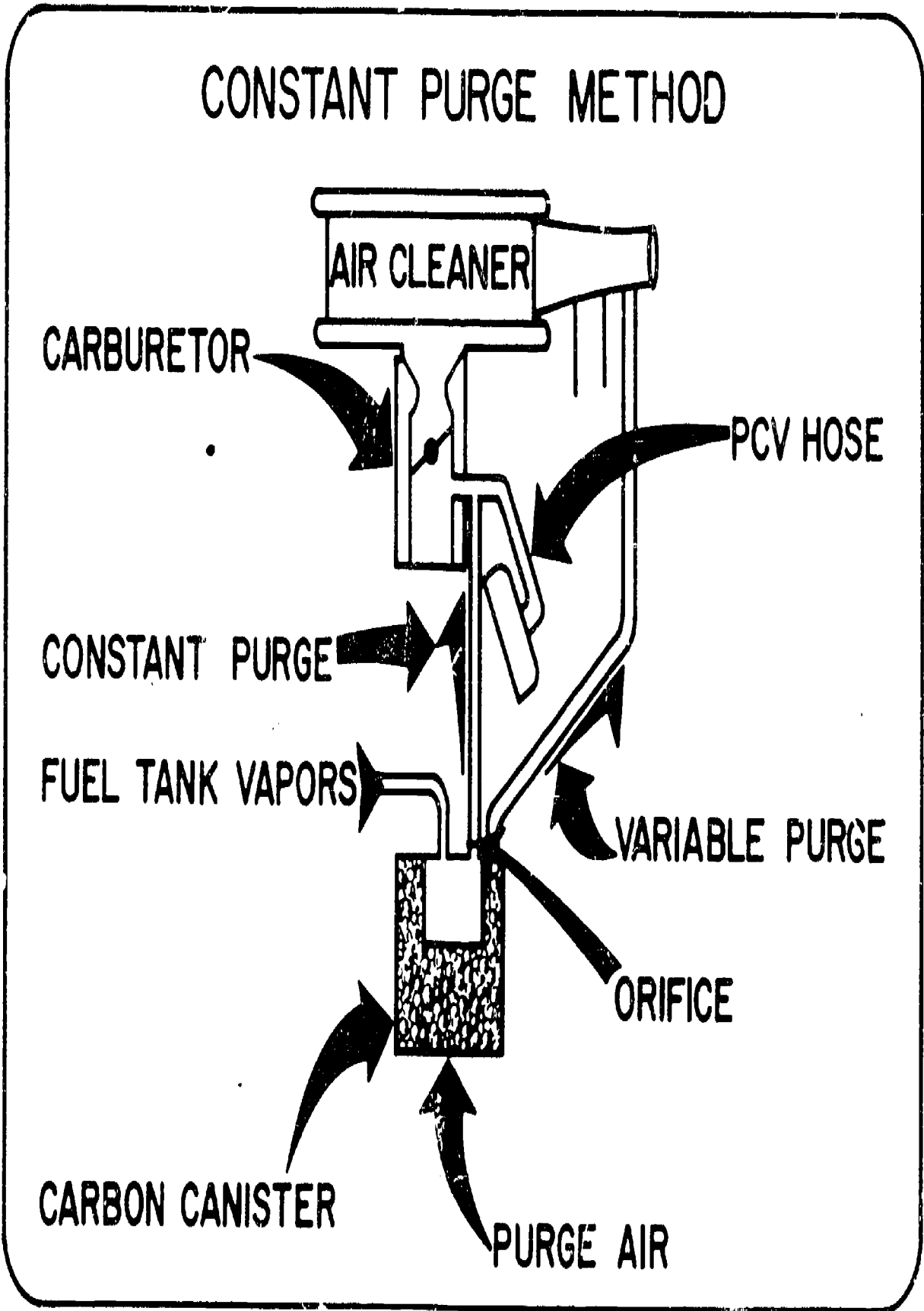

EVAPORATIVE EMISSIONS CONTROL SYSTEM

UNIT 5

JOB SHEET #1 - CHANGE CHARCOAL CANISTER FILTER

I. Tools required

As necessary

II. Procedure

- A. Disconnect hoses from top of canister.
- B. Remove canisters from mounting bracket.
- C. Remove cover from bottom of canister.
- D. Remove filter element.
- E. Install new filter element.
- F. Replace cover.
- G. Reinstall canister in mounting bracket.
- H. Reconnect hoses.

NOTE: These are BASIC PROCEDURES. Check the manufacturers service shop manual or technical manual for exact procedures for each make and model.

JOB SHEET #2 - TESTING THE FUEL TANK FILLER CAP

I. Tools required

None

II. Procedure

- A. Remove fuel tank filler cap.
- B. Apply oral vacuum and check that valve opens under vacuum and closes under pressure.
- C. If valve fails to open or close, replacement of the filler cap is required.

NOTE: These are BASIC PROCEDURES. Check the manufacturers service shop manual or technical manual for exact procedures for each make and model.

EVAPORATIVE EMISSIONS CONTROL SYSTEM

UNIT 5

T E S T

1. What is the purpose of the evaporative emission control system?

2. Identify the components of the evaporative emission control system.

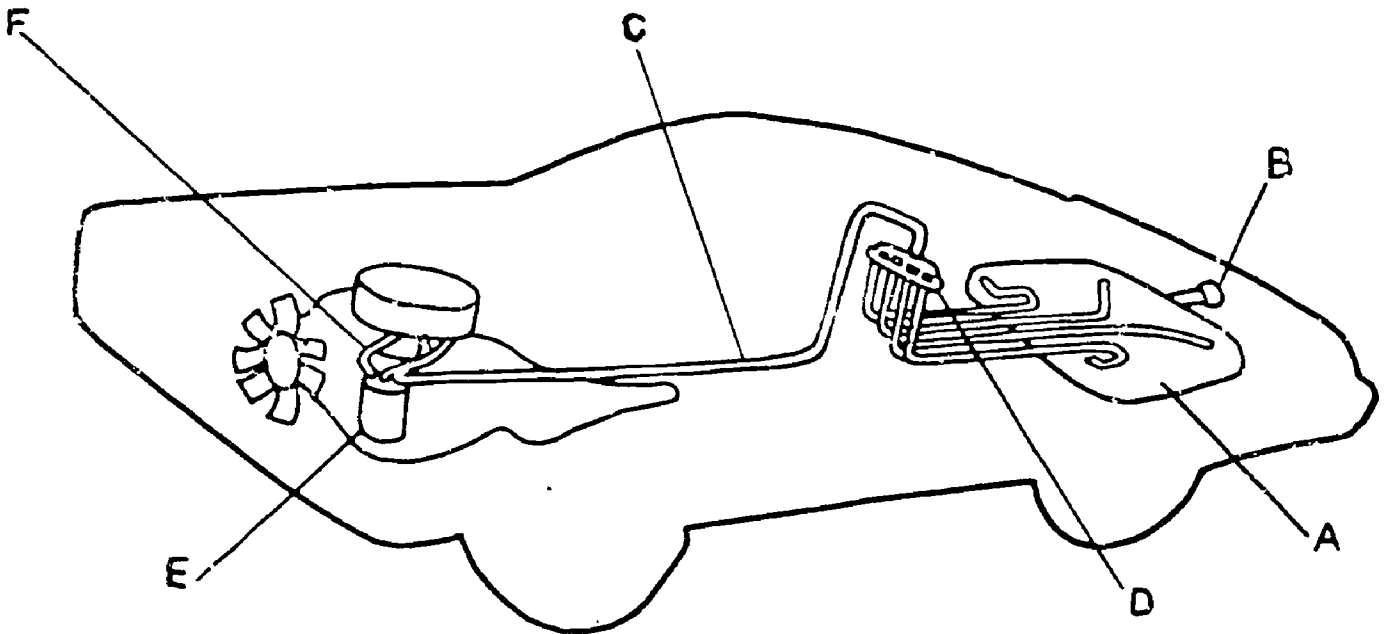

a.

b.

c.

d.

e.

f.

3. Explain the function of each component.

a.

b.

c.

d.

e.

f.

4. Explain the operation of the basic system.

5. List the methods of carburetor vapor control.

a.

b.

c.

d.

EVAPORATIVE EMISSIONS CONTROL SYSTEM

UNIT 5

ANSWERS TO TEST

1. Purpose of the evaporative emissions control system - To control the release of hydrocarbons to the atmosphere that results from fuel vapors escaping from fuel tanks and carburetor vents.
2. Identify basic components - TM-1
 - a. Fuel tank
 - b. Fuel tank filler cap
 - c. Vapor vent lines
 - d. Vapor-liquid separator
 - e. Charcoal canister
 - f. Purge line
3. Explain function of each component.
 - a. Fuel Tank - Stores the fuel in a sealed unit and is designed to allow for fuel expansion by having a special air space.
 - b. Fuel Tank Filler Cap - Seals fuel tank and acts as a relief valve to protect the tank from excessive pressure or vacuum.
 - c. Vapor Vent Lines - Allow vapors to escape from the fuel tank to the vapor-liquid separator.
 - d. Vapor-Liquid Separator - Allows vapors to pass on to the charcoal canister but prevents the passage of liquid fuel by means of standpipes or a float valve.
 - e. Charcoal Canister - Stores and traps fuel vapors in activated charcoal.
 - f. Purge Line - Allows passage of the fuel vapors from charcoal canister to the air cleaner or carburetor when the engine is running.

4. Basic system operation - As fuel increases in temperature it expands and gives off vapors. The expansion is compensated for by fuel tank design which has a built-in volume of approximately 11% of tank capacity for an air space. The vapors pass through the vapor vent lines to the vapor-liquid separator where the vapors pass forward to be trapped and stored in the charcoal canister. Liquid fuel is stopped at the vapor-liquid separator and returned to the fuel tank. When the engine is started, vapors are drawn from the charcoal canister to the carburetor or air cleaner and burned in the engine. As fuel is used and the vacuum in the fuel tank increases the filler cap opens to allow air into the tank to equalize the pressure and prevent damage.
5. Methods of carburetor vapor control.
 - a. Eliminate external vents.
 - b. Insulating washers on carburetor hold-down bolts.
 - c. Insulating gasket and radiant aluminum heat shield.
 - d. Venting carburetor fuel bowls to charcoal canister.

ENGINE MODIFICATIONS

UNIT 6

TERMINAL OBJECTIVE

After the completion of this unit the student will be able to explain the purpose of engine modifications and explain each engine modification and its purpose.

This will be evidenced by scoring 85% minimum on the unit test.

SPECIFIC OBJECTIVES

After completion of this unit the student will be able to:

1. Write the purpose of engine modifications.

2. Write the purpose of intake manifold modifications.

Explain how intake manifold modifications reduce emissions.

3. Write the purpose of higher engine operating temperatures.

Explain how higher coolant temperatures reduce emissions.

4. Write the purpose of modified combustion chambers.

Explain how modified combustion chambers reduce emissions.

5. Write the purpose of lower compression ratios.

Explain how lower compression ratios reduce emissions.

6. Write the purpose of modified valve timing.

Explain how modified valve timing reduces emissions.

ENGINE MODIFICATIONS

UNIT 6

SUGGESTED ACTIVITIES

- I. Instructor
 - A. Provide students with objective sheet
 - B. Provide students with information sheets
 - C. Make transparencies
 - D. Discuss terminal and specific objectives
 - E. Discuss information sheets
 - F. Give test
- II. Student
 - A. Read objective sheet
 - B. Study information sheet
 - C. Take test

INSTRUCTIONAL MATERIALS

- I. Included in this unit:
 - A. Objective sheet
 - B. Information sheet
 - C. Transparency masters
 - 6-TM-1 - Intake Manifold Modifications
 - 6-TM-2 - Combustion Chamber Modifications
 - D. Test
 - E. Answers to test

II. References

1. Chrysler Corporation, 1973 Emission Controls, Chrysler Corp., P. O. Box 2119, Detroit, Mich. 48231, Attention C. G. Palus.
2. Gargano Promotions. Vehicle Emission Control, 12824 West Seven Mile Road, Detroit, Mich. 48235, Gargano Promotions (1973).
3. Glenn, H. T. Glenn's Emission Control Systems, Henry Regnery Co., Chicago, Ill., (1972).
4. Heinen, C. M. We've Done the Job - What's Next? SAE Vehicle Emissions, Part III, Vol. 14 P.T.
5. Henein, N. A. and Patterson, D. J. Emissions From Combustion Engines and Their Control, Ann Arbor Science Publications, Inc., Ann Arbor, Mich., (1972).
6. Springer, G. S. and Patterson, D. J. Engine Emission Pollutant Formation and Measurement, Plenum Press, 227 W. 17th Street, New York, N. Y.,(1973).

ENGINE MODIFICATIONS

UNIT 6

INFORMATION SHEET

- I. PURPOSE OF ENGINE MODIFICATIONS - To redesign various engine components and change certain operating conditions to achieve more complete combustion and reduce engine emissions.
- II. PURPOSE OF INTAKE MANIFOLD MODIFICATIONS - TM-1 - To reduce cylinder to cylinder and cycle to cycle variations in air-fuel mixtures which results in more complete combustion and lower HC and CO emissions.
- A. Intake manifolds have been redesigned with more exact passage sizes, a smoother finish on passages and better matching of manifold to cylinder head parts.
- B. Other modifications include redesigned crossover passages for exhaust gases so better vaporization of the fuel mixture can occur during warm-up, and a single plane manifold that reduces the size of manifold pulsations and allows a more constant distribution of fuel to each cylinder.
- C. These modifications result in a more even distribution of the air-fuel mixture to each cylinder.
- III. PURPOSE OF HIGHER ENGINE OPERATING TEMPERATURES - Higher coolant temperatures result in higher combustion chamber wall temperatures and more complete combustion.

Thermostats that control coolant temperatures between 81°C(180°F) and 92°C(200°F) provide for faster engine warm up and reduced hydrocarbon emissions.

NOTE: On later models 1971-74 82°C(185°F) thermostats are being used to lower combustion chamber temperatures for the reduction of NO_x emissions.

- IV. PURPOSE OF MODIFIED COMBUSTION CHAMBERS - TM-2 - To reduce cold surface areas and increase quench areas to lower the amount of fuel that is unburned in these areas.
- A. More closely made head gaskets that better follow combustion chamber shape have reduced the small space between the cylinder head and block where quenching could occur and result in unburned hydrocarbons.
 - B. Larger exhaust valves have been used to reduce the amount of exhaust backflow that could dilute the air-fuel mixture.
- V. PURPOSE OF LOWER COMPRESSION RATIOS - Compression ratios were primarily lowered to allow the use of lead-free, low-octane gasoline.
- A. The required changes in combustion chamber design to lower the compression ratio also resulted in lower emissions.
 - B. The lower compression ratio and retarded ignition timing results in higher exhaust manifold temperatures that burn the unburned hydrocarbons from combustion.
- VI. PURPOSE OF MODIFIED VALVE TIMING - To reduce peak combustion chamber temperatures and lower emissions.
- A. Camshafts with extended overlap tend to cause some dilution of the air-fuel mixture with exhaust gases.
 - B. This dilution of the fuel mixture results in lower combustion temperatures and reduces NO_x emissions.
- NOTE: Earlier designs reduced valve overlap to lower HC emissions.

INTAKE MANIFOLD MODIFICATIONS

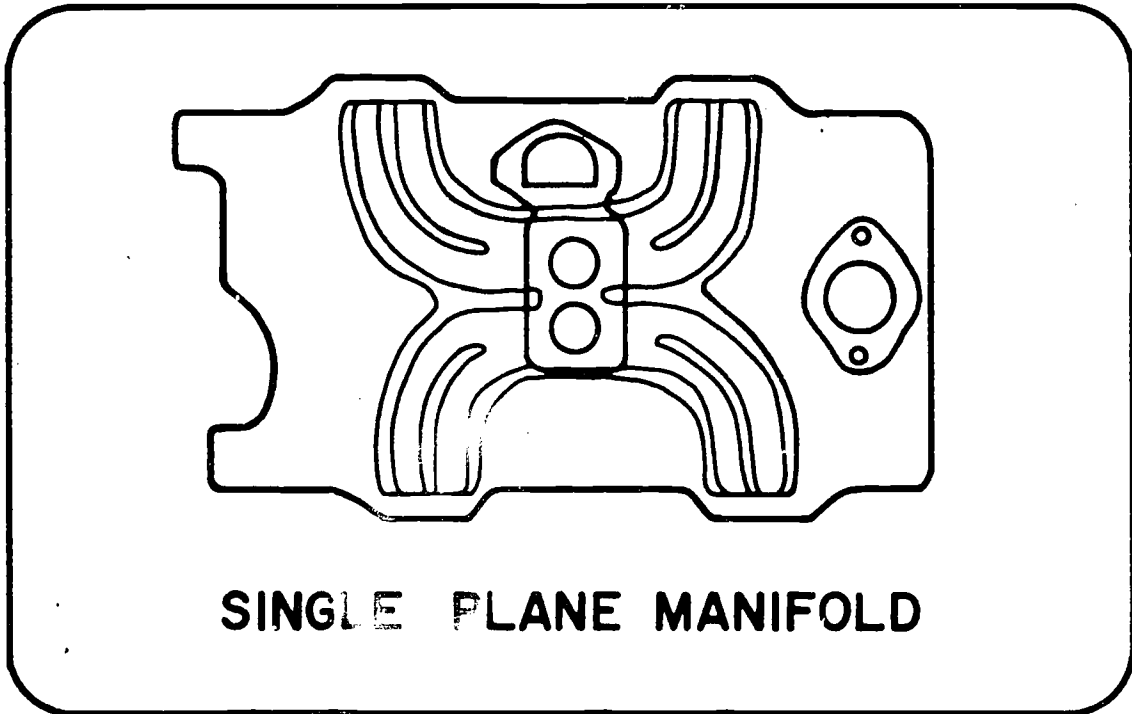
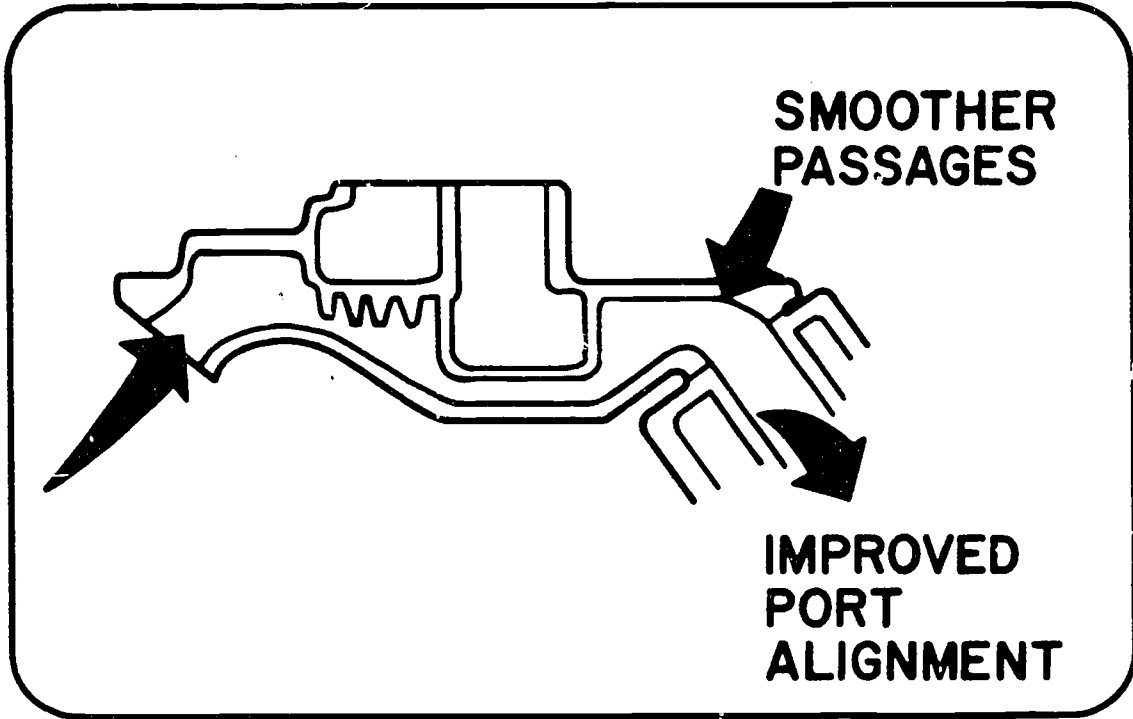

COMBUSTION CHAMBER MODIFICATIONS

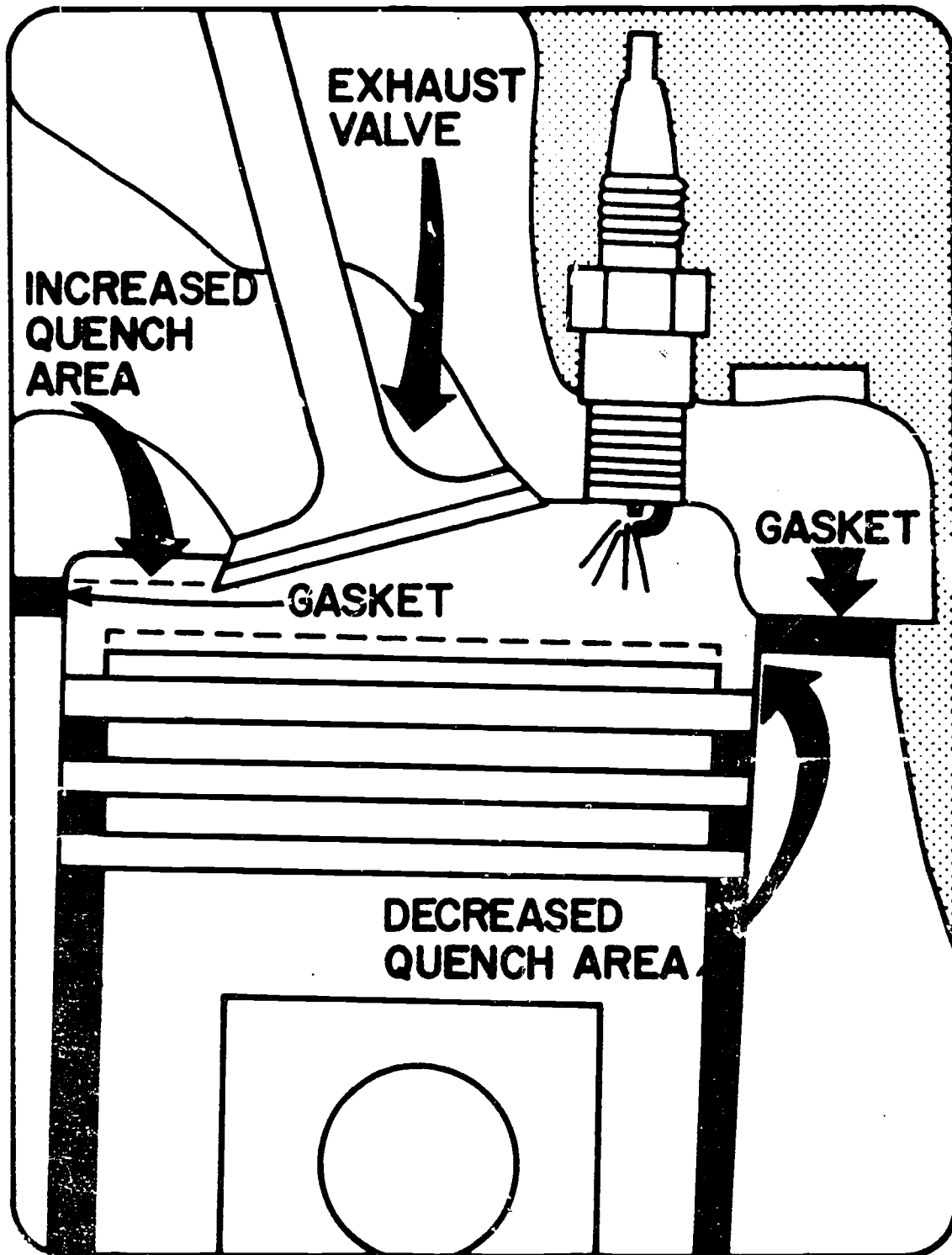

ENGINE MODIFICATIONS

UNIT 6

T E S T

1. What is the purpose of engine modifications?

2. What is the purpose of the intake manifold modifications?

Explain how intake manifold modifications reduce emissions.

3. What is the purpose of higher engine operating temperatures?

Explain how higher coolant temperatures reduce emissions.

4. What is the purpose of modified combustion chambers?

Explain how modified combustion chambers reduce emissions.

5. What is the purpose of lower compression ratios?

Explain how lower compression ratios reduce emissions.

6. What is the purpose of modified valve timing?

Explain how modified valve timing reduces emissions.

ENGINE MODIFICATIONS

UNIT 6

ANSWERS TO TEST

1. What is the purpose of engine modifications?

To redesign various engine components and parameters to achieve more complete combustion and reduce engine emissions.

2. What is the purpose of the intake manifold modifications?

To reduce cylinder to cylinder and cycle to cycle variations in air-fuel mixtures which results in more complete combustion and lower hydrocarbon and carbon monoxide emissions.

Explain how intake manifold modifications reduce emissions.

1. Intake manifolds have been redesigned with more exact passage sizes, a smoother finish on passages and better matching of manifold to cylinder head parts.
2. Other modifications include redesigned crossover passages for exhaust gases so better vaporization of the fuel mixture can occur during warm-up, and a single plane manifold that reduces the size of manifold pulsations and allows a more constant distribution of fuel to each cylinder.
3. These modifications result in a more even distribution of the air-fuel mixture to each cylinder.

3. What is the purpose of higher engine operating temperatures?

Higher coolant temperatures result in higher combustion chamber wall temperatures and more complete combustion.

Explain how higher coolant temperatures reduce emissions.

1. Thermostats that control coolant temperatures between 81°C (180°F) and 92°C (200°F) provide for faster engine warm up and reduced hydrocarbon emissions.

4. What is the purpose of modified combustion chambers?

To reduce cold surface areas and increase quench heights to limit the amount of fuel that is unburned in these areas.

Explain how modified combustion chambers reduce emissions.

1. More closely made head gaskets that better follow combustion chamber shape have reduced the small space between the cylinder head and block where quenching could occur and result in unburned hydrocarbons.
2. Larger exhaust valves have been used to reduce the amount of exhaust backflow that could dilute the air-fuel mixture.

5. What is the purpose of lower compression ratios?

Compression ratios were primarily lowered to allow the use of lead-free, low-octane gasoline.

Explain how lower compression ratios reduce emissions.

1. The required changes in combustion chamber design to lower the compression ratio also resulted in lower emissions.
2. The lower compression ratio results in higher exhaust manifold temperatures that further burn the unburned hydrocarbons from combustion.

6. What is the purpose of modified valve timing?

To reduce peak combustion chamber temperatures and lower emissions.

Explain how modified valve timing reduces emissions.

1. Camshafts with extended overlap tend to cause some dilution of the air-fuel mixture with exhaust gases.
2. This dilution of the fuel mixture results in lower combustion temperatures and reduces NO_x emissions.

CARBURETOR MODIFICATIONS

UNIT 7

TERMINAL OBJECTIVE

After completion of this unit the student will be able to explain the purpose of carburetor modifications. He will be able to list the modifications made to carburetors and the purposes of these modifications.

This will be evidenced by scoring 85% minimum on the unit test.

SPECIFIC OBJECTIVES

After completion of this unit the student will be able to:

1. Write the purpose of carburetor modifications.
2. Write the purpose of the choke system modifications.
3. List the choke system modifications.
4. Write the purpose of idle system modifications.
5. List the idle system modifications.
6. Write the purpose of the triple venturi in carburetors.

CARBURETOR MODIFICATIONS

UNIT 7

SUGGESTED ACTIVITIES

- I. Instructor
 - A. Provide students with objective sheet
 - B. Provide students with information and job sheets
 - C. Make transparencies
 - D. Discuss terminal and specific objectives
 - E. Discuss information sheets
 - F. Demonstrate and discuss procedures outlined on job sheets
 - G. Give test
- II. Student
 - A. Read objective sheet
 - B. Study information sheet
 - C. Demonstrate ability to accomplish the procedures
 - D. Take test

INSTRUCTIONAL MATERIALS

- I. Included in this unit:
 - A. Objective sheet
 - B. Information sheet
 - C. Transparency masters
 - 7-TM-1 - Electric Choke System
 - 7-TM-2 - Stainless Steel Thermostatic Coil Well
 - 7-TM-3 - Staged Choke Pulldown
 - 7-TM-4 - Off Idle Air Bleed Adjusting Screw
 - 7-TM-5 - Fixed Orifice Restriction Idle Limiters

7-TM-6 - Stoplock Screws

7-TM-7 - External Idle Control Limiters

7-TM-8 - Idle Speed Control (Solenoid)

7-TM-9 - Carburetor Dash Pot

7-TM-10 - Triple Venturi

D. Test

E. Answers to test

II. References

1. 1973 Chevrolet Service Manual (contact local dealer).
2. Chrysler Corporation, 1973 Emission Controls, Chrysler Corp., P. O. Box 2119, Detroit, Mich. 48231, Attention C. G. Palus.
3. Gargano Promotions. Vehicle Emission Control, 12824 West Seven Mile Road, Detroit, Mich. 48235, Gargano Promotions (1973).
4. Glenn, Harold T. Glenn's Emission Control Systems, Chicago, Ill., Henry Regnery Co., (1972).

CARBURETOR MODIFICATIONS

UNIT 7

INFORMATION SHEET

- I. PURPOSE OF CARBURETOR MODIFICATIONS - To reduce hydrocarbons and carbon monoxide emissions to atmosphere especially during periods of engine warm up, idle and deceleration. This is accomplished by modifications that keep the air-fuel mixture from being excessively rich when it reaches the combustion chamber.
- II. PURPOSE OF AUTOMATIC CHOKE MODIFICATIONS - To allow faster opening of automatic chokes during warm up, to reduce rich warm up air-fuel mixtures and reduce the emission of hydrocarbons and carbon monoxide during this period.
- III. TYPES OF AUTOMATIC CHOKE MODIFICATIONS.
 - A. Electric Assist Chokes - TM-1 - Supplies additional heat to the thermostatic choke coil to reduce the amount of time the choke operates and reduce the amount of engine heat required to open the choke.
 - B. Stainless Steel Thermostatic Coil Wells - TM-2 - Allows faster heat transfer to the thermostatic choke coil thus providing a shorter time for choke operation.
 - C. Two-Stage Choke Pulldown - TM-3 - Uses a temperature sensing bi-metallic "snap" valve to control intake manifold vacuum and a timing device which consists of a linkage diaphragm and a vacuum diaphragm with a silicone liquid between them whose flow is controlled by an orifice. Above 16°C(60°F) the bimetallic valve opens allowing manifold vacuum to cause a low pressure area. Atmospheric pressure forces the linkage diaphragm to overcome spring tension and force fluid from the forward chamber through the orifice to the rear chamber. This opens the choke 15-20 seconds after the engine is started.

IV. PURPOSE OF IDLE SYSTEM MODIFICATIONS - To prevent idle mixtures that are excessively rich and thereby reduce the emission of HC and CO at idle conditions.

V. TYPES OF IDLE SYSTEM MODIFICATIONS.

A. Off-Idle Air Bleed Adjusting Screw - TM-4 - Allows establishing narrower off-idle limits which reduces the richer mixture normally required. These are set at the factory with flow meters and then sealed.

B. Internal Idle Control Limiters -

1. Internal Needle Limiters - TM-5 - Located in the internal idle circuit passage and prevent an overrich mixture even if the external idle adjusting screw is turned out all the way. The internal limiter needles are preset at the factory and sealed.

2. Stop Lock Screw - TM-6 - Fits in the necked-down portion of the idle mixture adjusting screw and restricts the travel of the idle mixture adjusting screw thereby preventing excessively rich mixtures.

3. Fixed Orifice Restriction - TM-5 - Located in the internal idle circuit passage and prevent an overly rich idle mixture.

C. External Idle Control Limiters - TM-7 - These are plastic caps with tabs on them. The idle is preset at the factory and the caps are installed. The tabs contact the body of the carburetor and limit adjusting range to 3/4 of a turn.

- D. Idle Speed Control (Solenoid) - TM-8 - Accomplished by a solenoid that allows higher idle speeds so air-fuel mixtures can be set closer to approximately 15:1 to improve combustion at idle. The solenoid holds the throttle blades at this higher idle speed during deceleration which allows more air to enter and improves combustion during deceleration. When the ignition switch is turned off, the solenoid is deenergized and allows the throttle blades to shut completely to prevent "dieseling".
- E. Carburetor Dash Pot - TM-9 - A device that can be controlled by a hydraulic system, an internal spring and atmospheric pressure or manifold vacuum. This device holds the throttle blades open for a longer period of time during deceleration. This in turn allows more air to enter the manifold and provides a more combustible mixture during deceleration. This reduces emissions during deceleration.
- VI. TRIPLE VENTURI - TM-10 - These allow three velocity increases in the carburetor. These increases in air speed provide better mixing of the air-fuel mixture thereby a more even air-fuel mixture reaches each cylinder.

ELECTRIC CHOKE SYSTEM

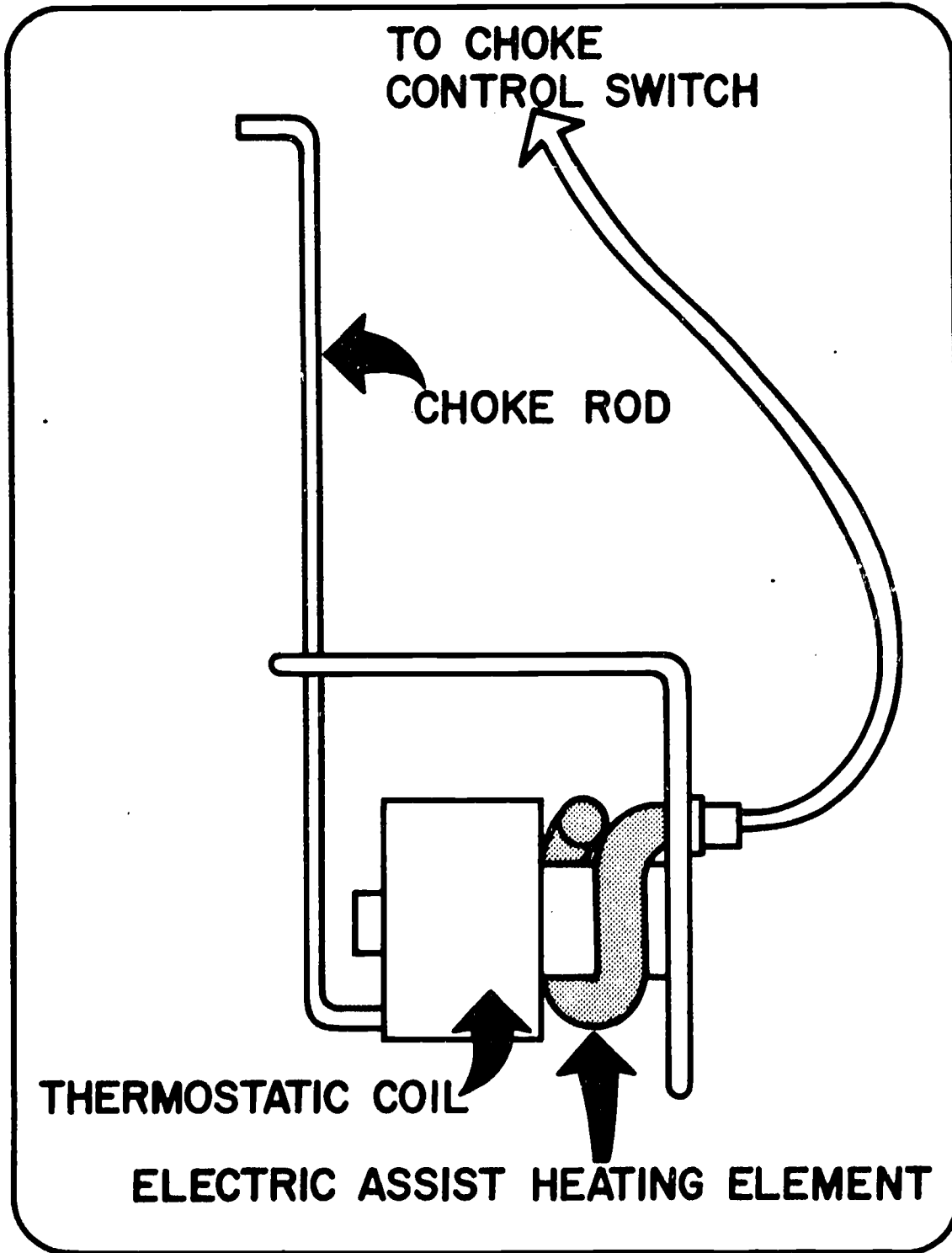

STAINLESS STEEL THERMOSTATIC COIL WELL

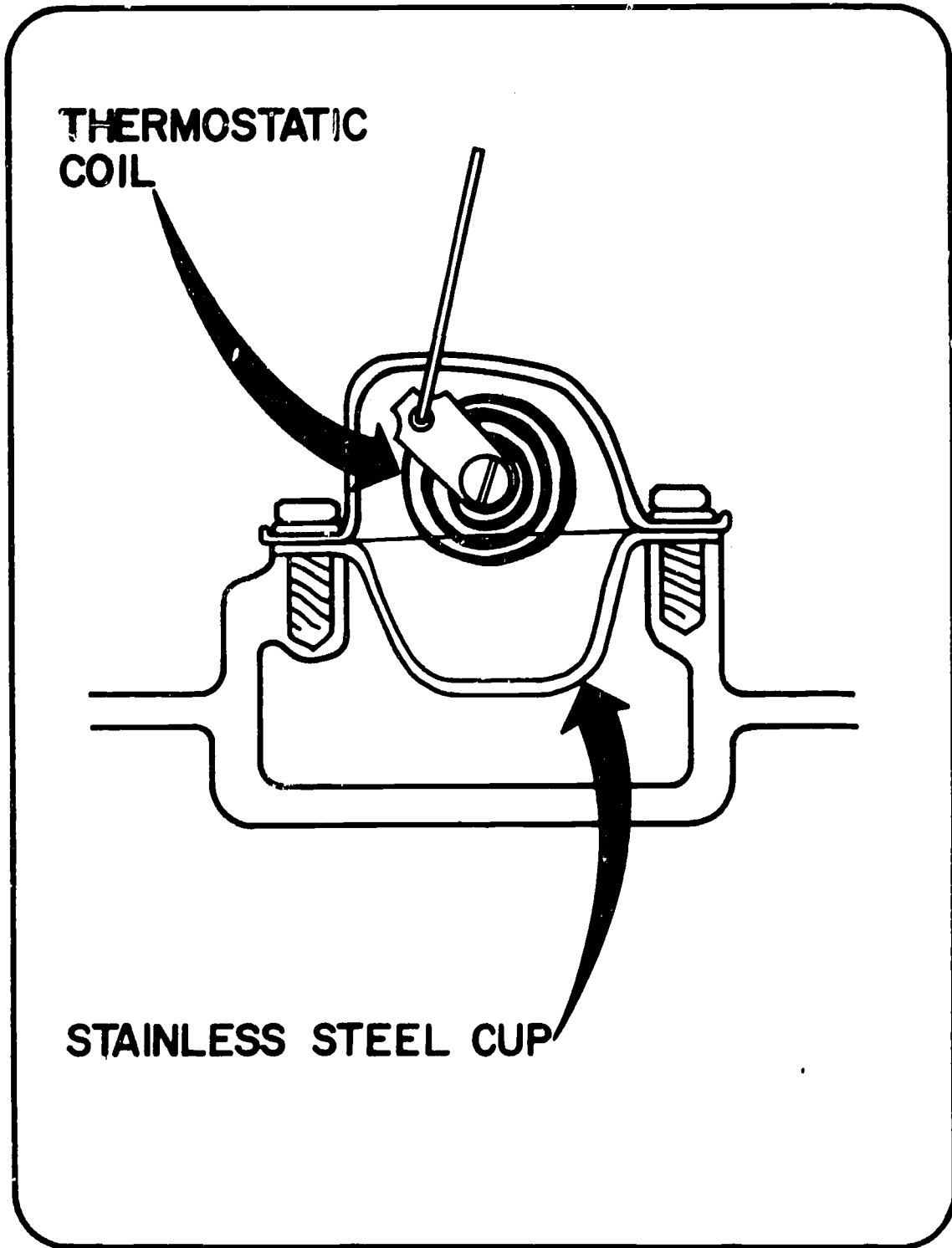

STAGED CHOKE PULLDOWN

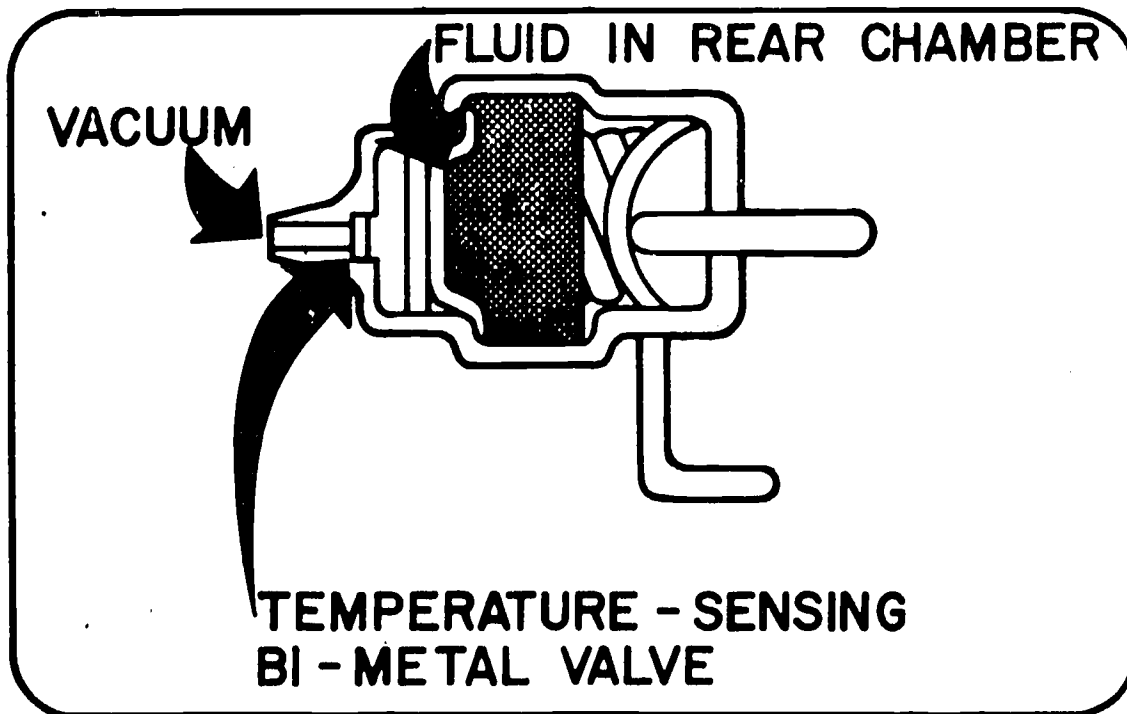
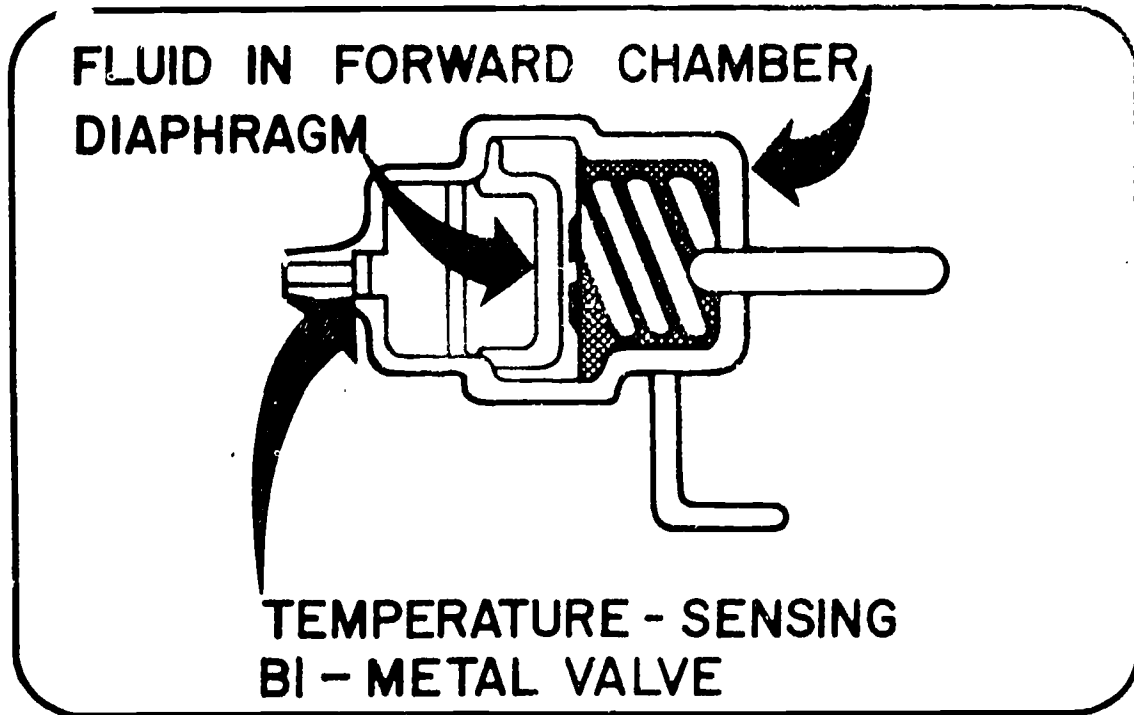

OFF IDLE AIR BLEED ADJUSTING SCREW

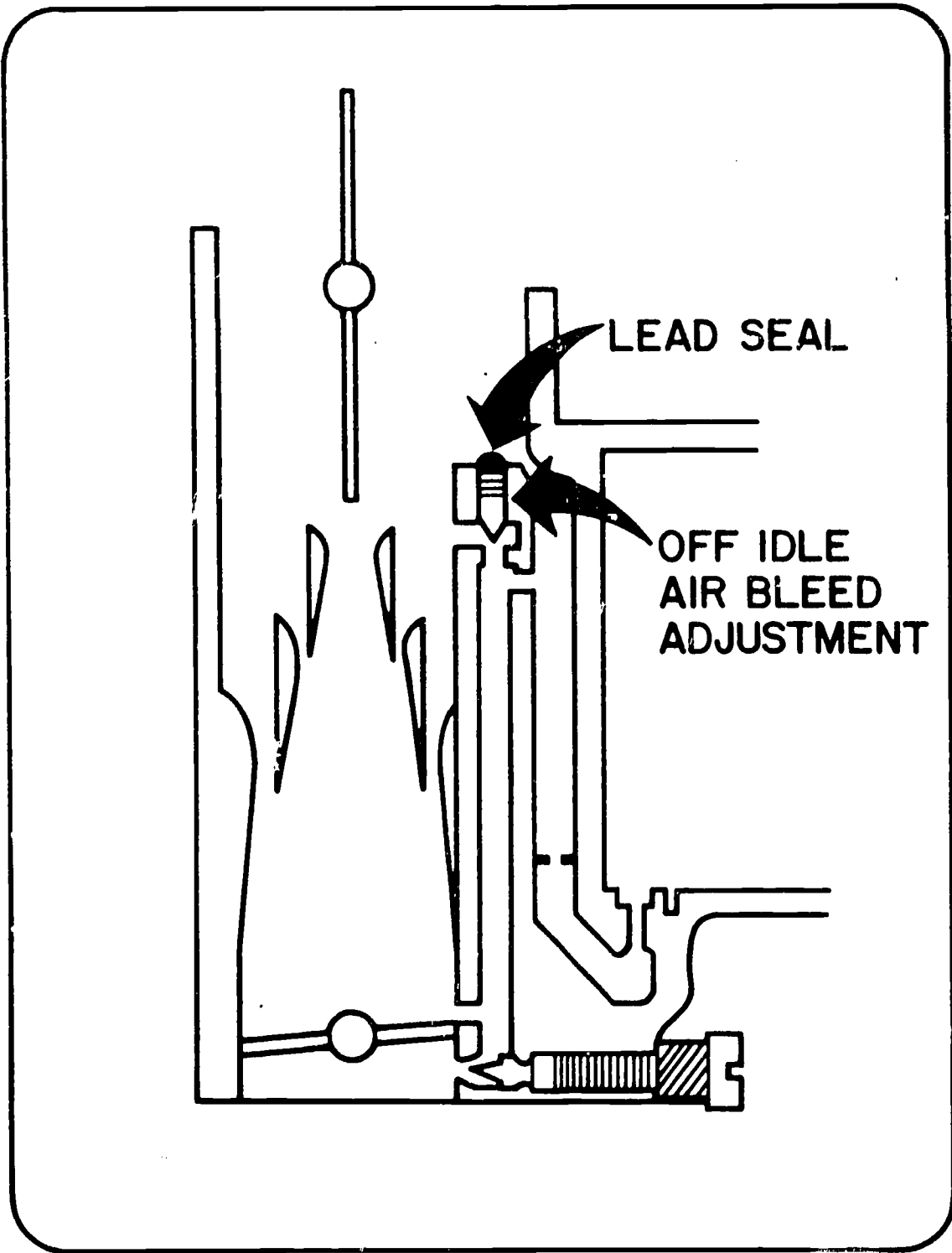

121

TM-4

FIXED ORIFICE RESTRICTION IDLE LIMITERS

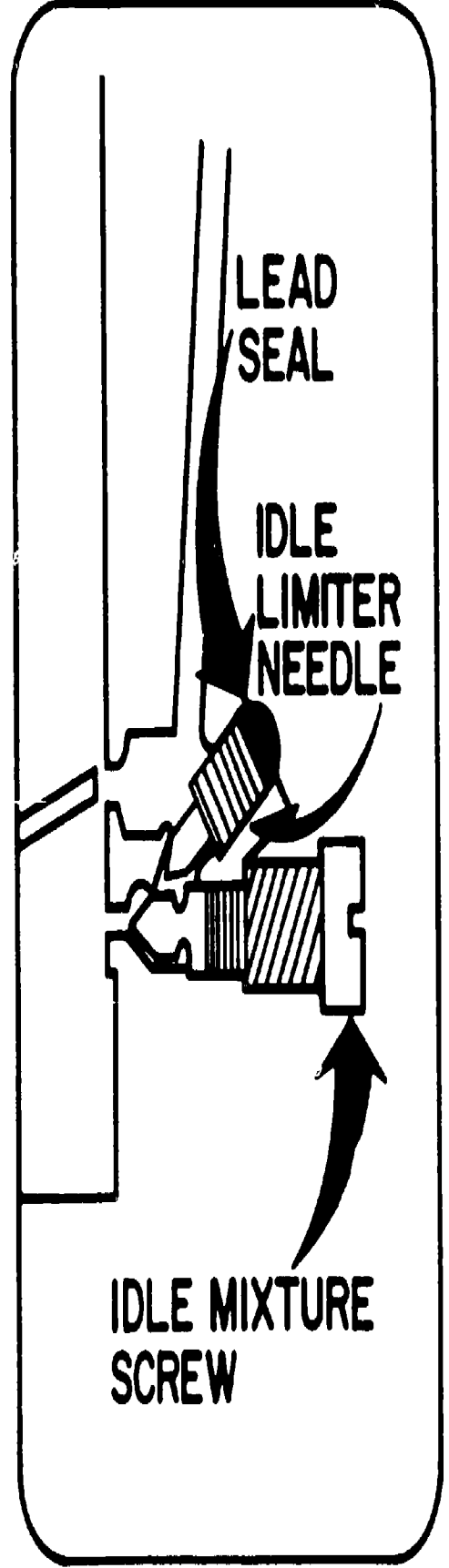
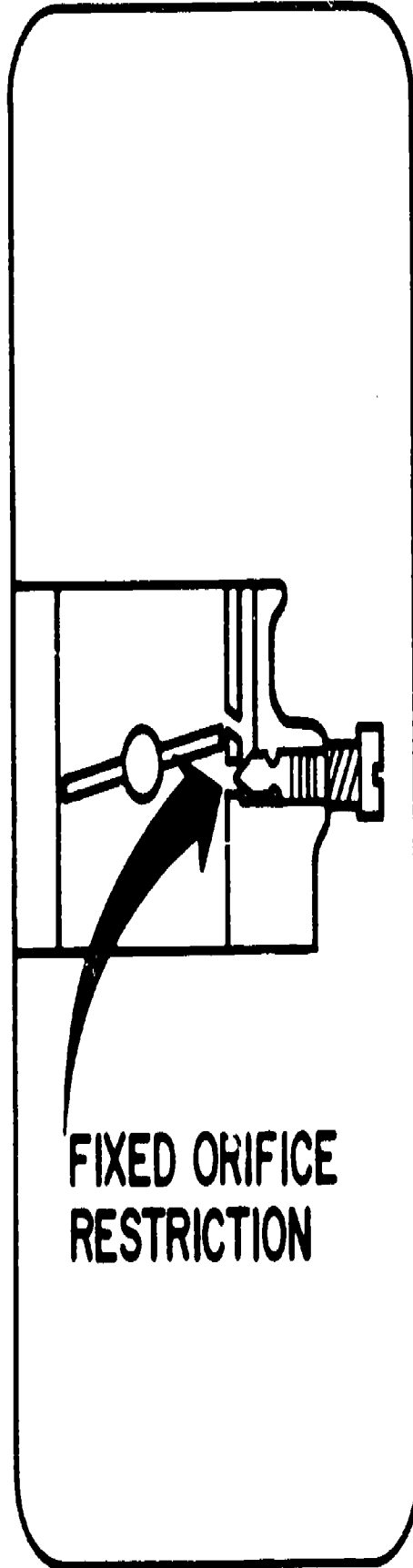
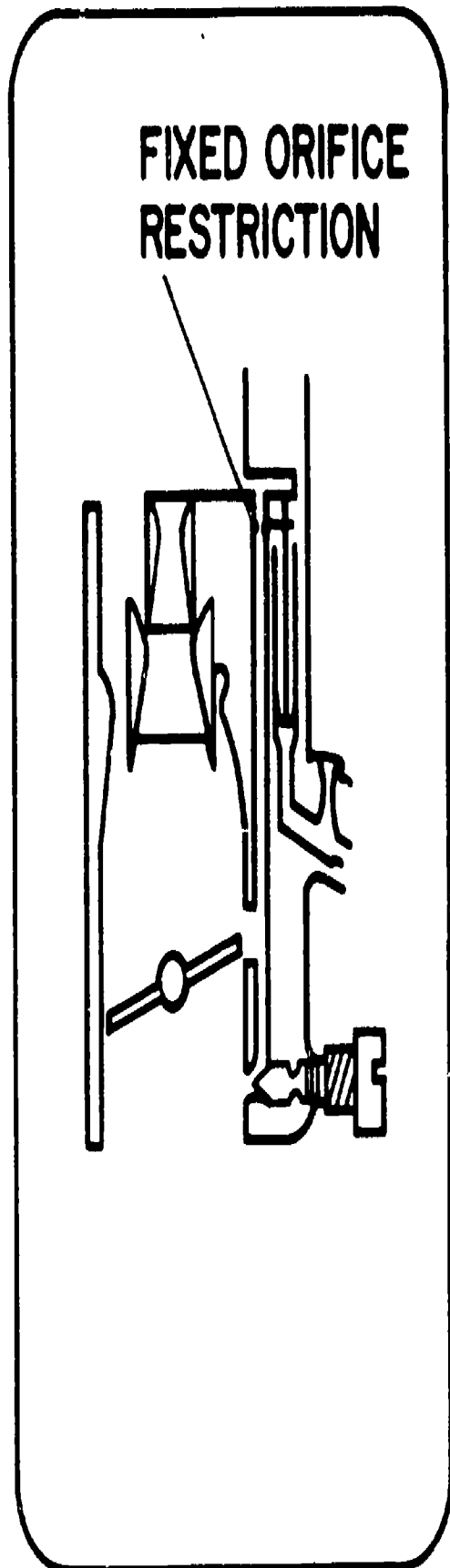

STOP LOCK SCREW

NECKED DOWN TO
CLEAR STOP SCREW

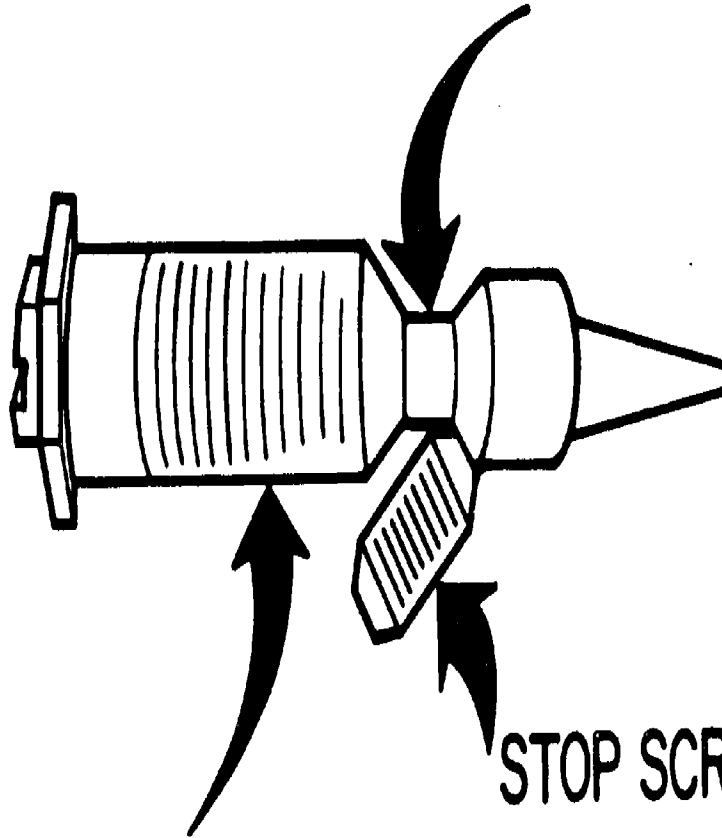

IDLE MIXTURE
ADJUSTING SCREW

EXTERNAL IDLE CONTROL LIMITERS

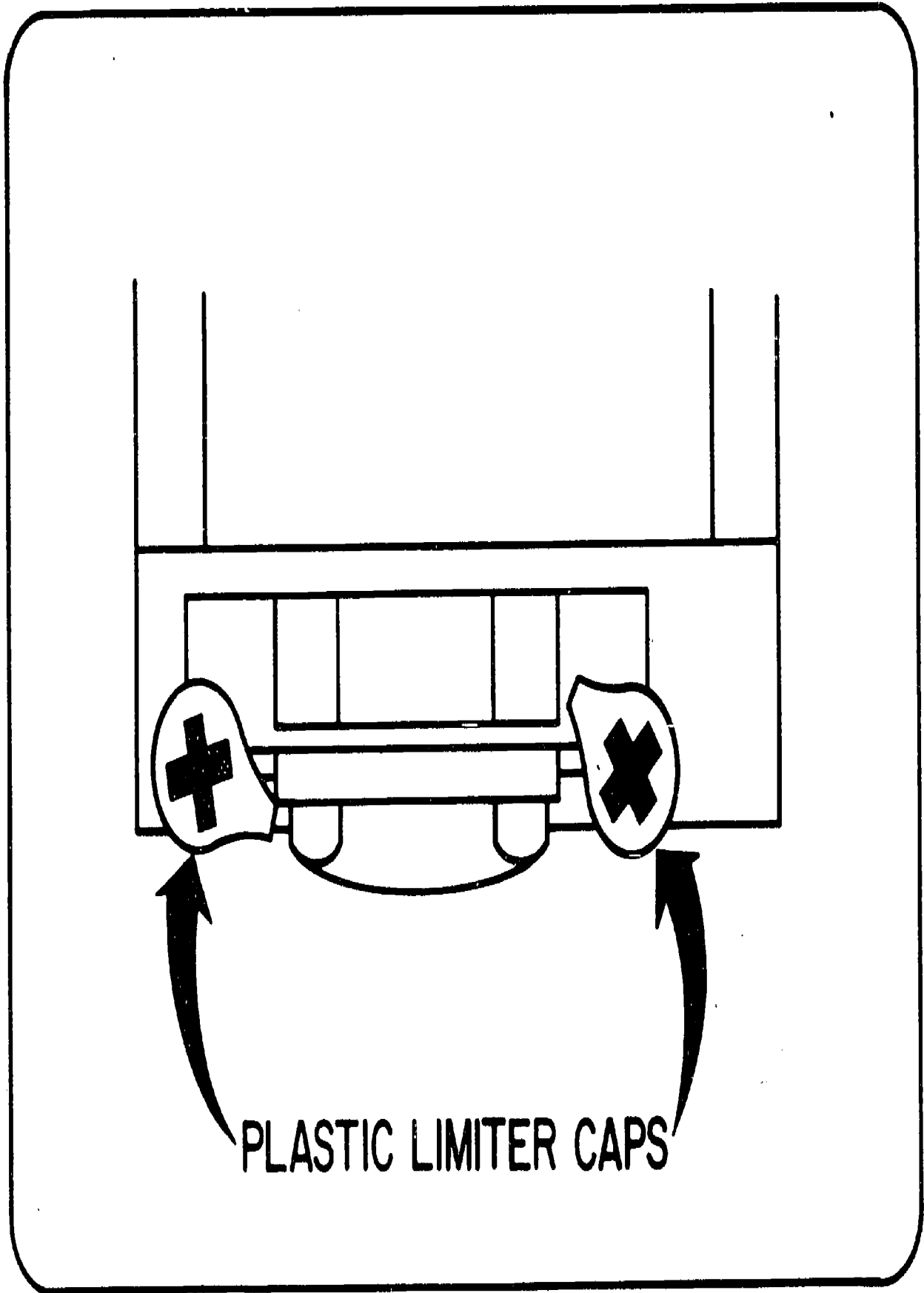

PLASTIC LIMITER CAPS

IDLE SPEED CONTROL (SOLENOID)

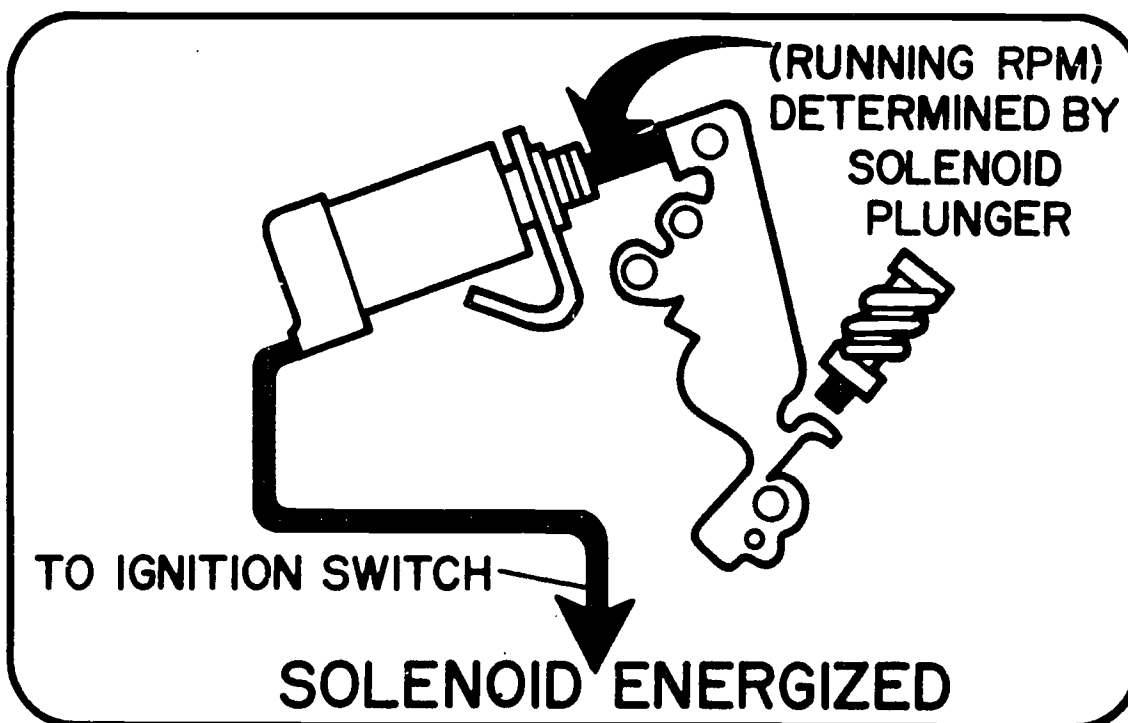
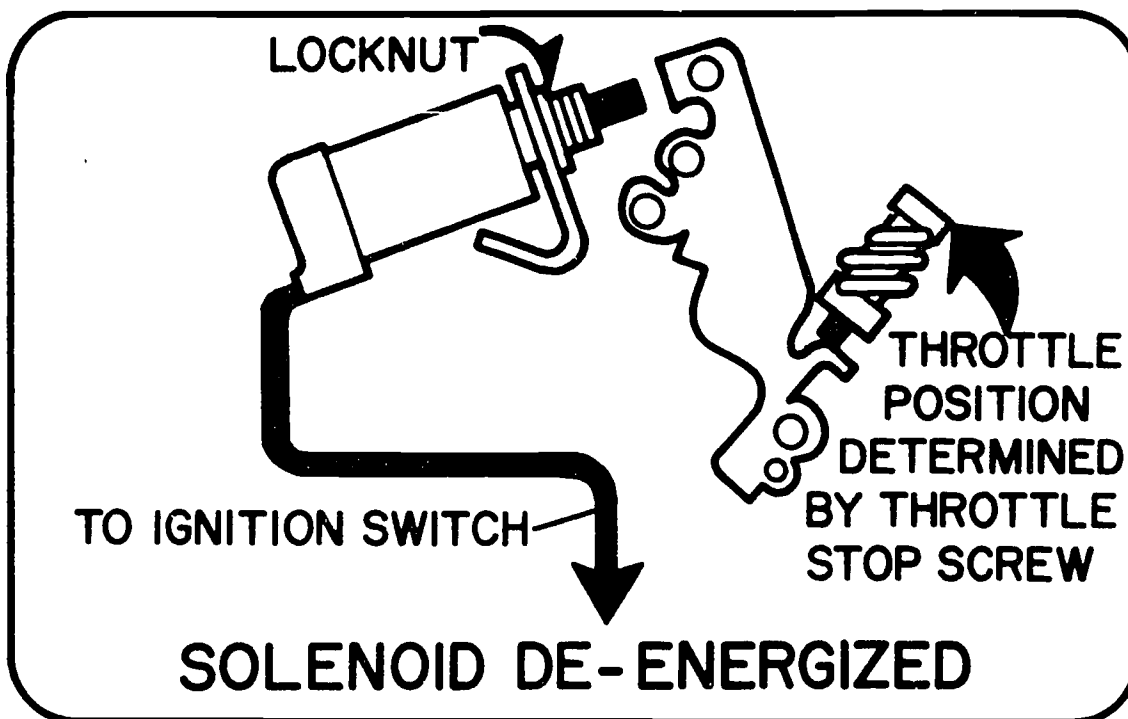

CARBURETOR DASHPOT

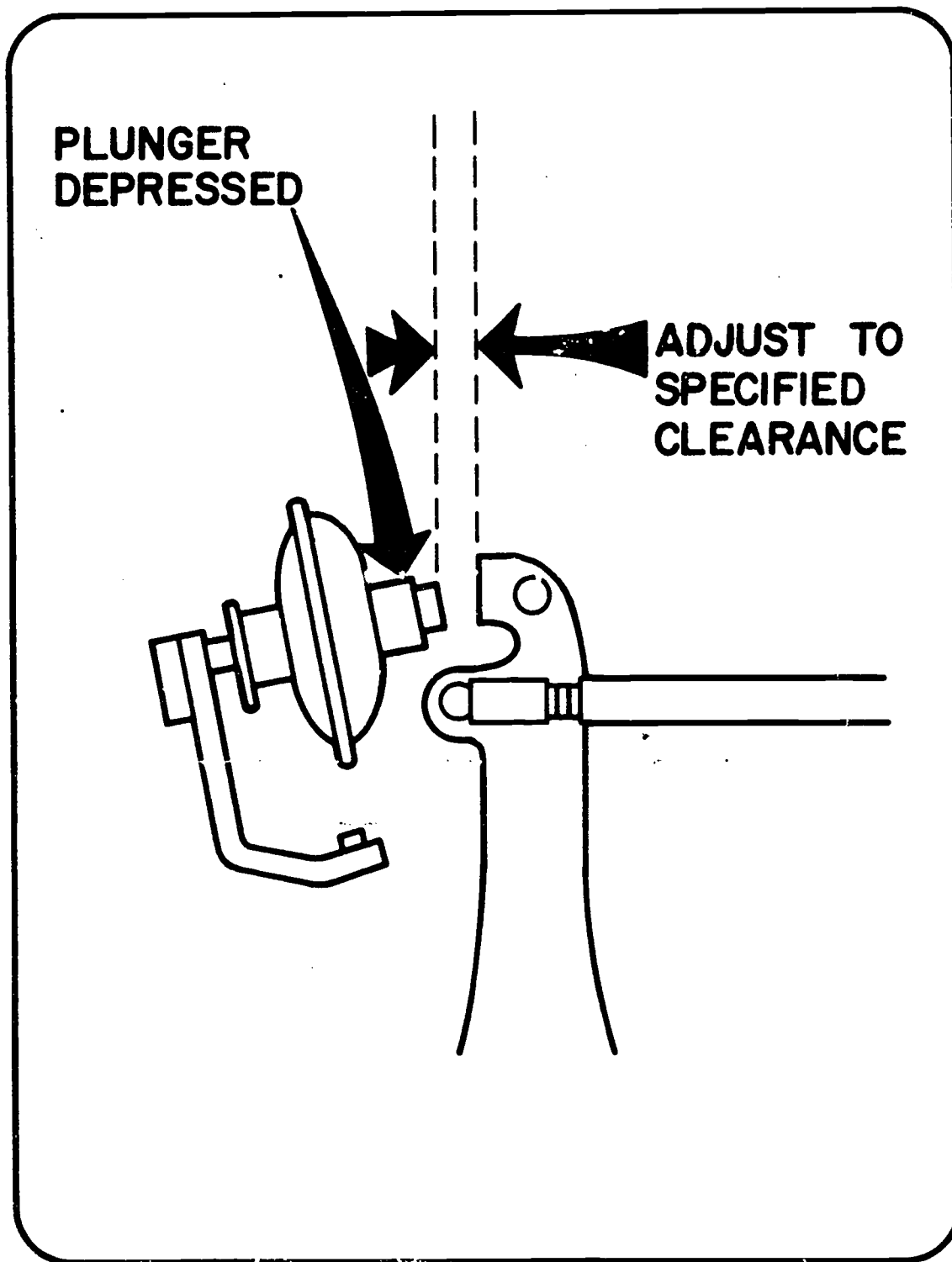

129

TM-9

TRIPLE VENTURI

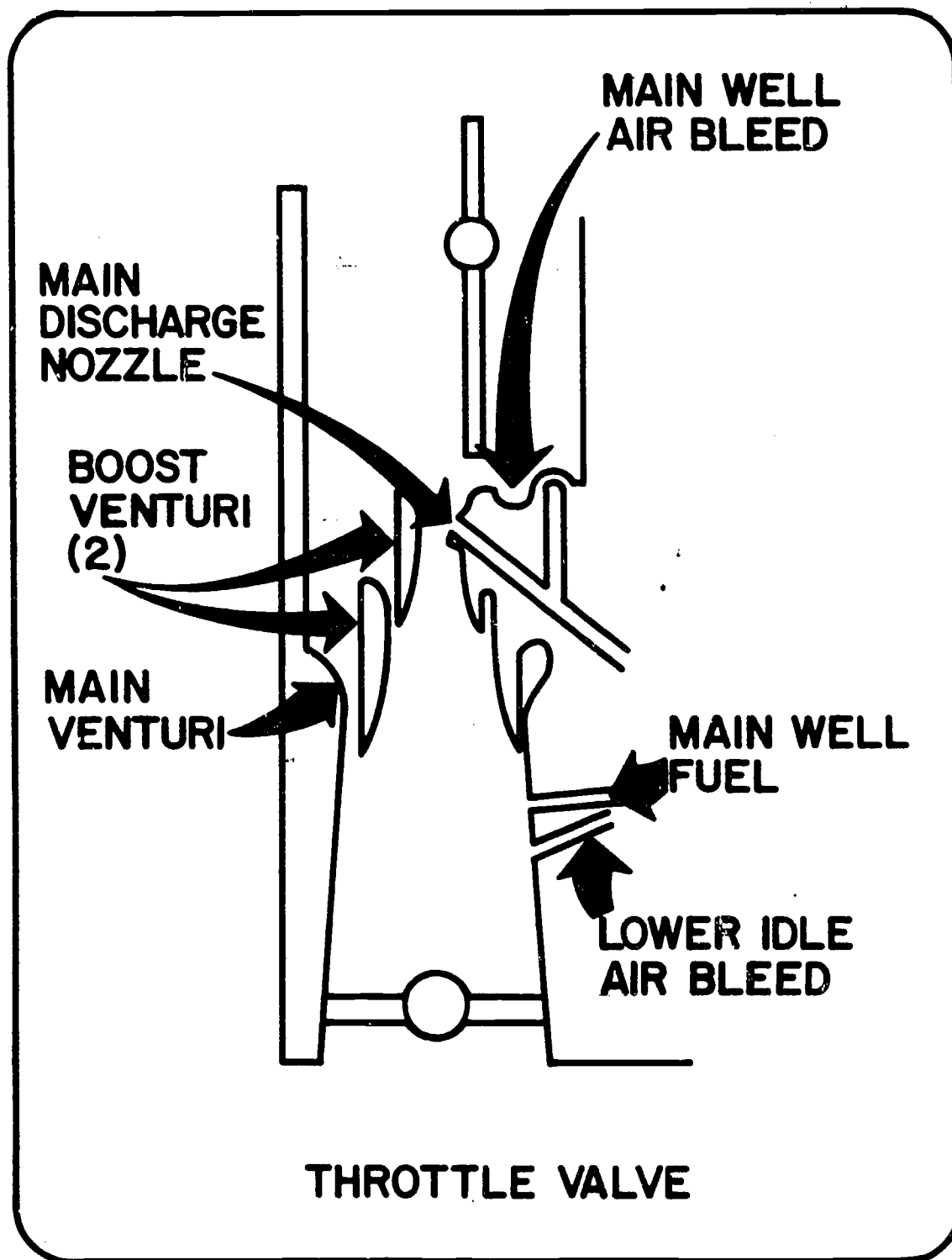

CARBURETOR MODIFICATIONS

UNIT 7

T E S T

1. What is the purpose of carburetor modifications?

2. What is the purpose of choke system modifications?

3. List the choke system modifications.
 - a.

 - b.

 - c.

4. What is the purpose of idle system modifications?

5. List the idle system modifications.
 - a.

b. (1)

(2)

(3)

c.

d.

e.

6. What is the purpose of triple venturi in carburetors?

CARBURETOR MODIFICATIONS

UNIT 7

ANSWERS TO TEST

1. Purpose of carburetor modifications - To reduce HC and CO emissions during periods of engine warm up, idle and deceleration.
2. Purpose of choke system modification - To allow faster opening of automatic chokes during warm up and reduce rich air-fuel mixtures during this period thereby reducing HC and CO emissions.
3. List the choke system modifications.
 - a. Electric assist choke.
 - b. Stainless steel thermostatic choke wells.
 - c. Two-stage choke pulldown.
4. Purpose of idle system modifications - To prevent idle mixtures that are excessively rich and reduce emissions of HC and CO.
5. List the idle system modifications.
 - a. Off-idle air bleed adjusting screw.
 - b. Internal idle control limiters.
 - (1) Internal
 - (2) Stop lock screws
 - (3) Fixed orifice restriction
 - c. External idle control limiters.
 - d. Idle speed control solenoid.
 - e. Carburetor dash pot.
6. Purpose of triple venturi - To increase air and fuel velocity three times. This allows better mixing of the fuel with the air and results in a more evenly mixed fuel mixture.

IGNITION TIMING SYSTEMS

UNIT 8

TERMINAL OBJECTIVE

After completion of this unit the student will be able to explain the purpose of the ignition timing system. He will be able to explain the purpose and operation of each of the ignition timing systems. The student will be able to visually inspect, test and service these systems.

This will be evidenced through demonstration and scoring 85% minimum on the unit test.

SPECIFIC OBJECTIVES

After completion of this unit the student will be able to:

1. Write the purpose of ignition timing systems.
2. Write the purpose of the ported vacuum advance system.
3. Discuss in writing the operation of the ported vacuum advance system.
4. Write the purpose of the deceleration valve.
5. Discuss in writing the operation of the deceleration valve.
6. Write the purpose of the dual diaphragm vacuum advance unit.
7. Discuss in writing the operation of the dual diaphragm vacuum advance unit.
8. Write the purpose of the temperature sensing distributor control valve.
9. Explain the operation of the temperature sensing distributor control valve.
10. Demonstrate the ability to:
 - a. Test deceleration control valve operation.
 - b. Test dual diaphragm vacuum advance unit.
 - c. Test temperature sensing distributor control valve.

IGNITION TIMING SYSTEMS

UNIT 8

SUGGESTED ACTIVITIES

- I. Instructor
 - A. Provide students with objective sheets
 - B. Provide students with information and job sheets
 - C. Make transparencies
 - D. Discuss terminal and specific objectives
 - E. Discuss information sheets
 - F. Demonstrate and discuss procedure outlined on job sheets
 - G. Give test
- II. Student
 - A. Read objective sheet
 - B. Study information sheet
 - C. Demonstrate ability to accomplish procedures
 - D. Take test

INSTRUCTIONAL MATERIALS

- I. Included in this unit:
 - A. Objective sheet
 - B. Information sheets
 - C. Transparency masters
 - 8-TM-1 - Ported Vacuum Advance
 - 8-TM-2 - Deceleration Valve Operation
 - 8-TM-3 - Dual Diaphragm Vacuum Advance Unit and Operation
 - 8-TM-4 - Temperature Sensing Distributor Control Valve
 - 8-TM-5 - Temperature Sensing Distributor Control Valve Operation

D. Job Sheets

1. Testing deceleration control valve operation
2. Testing dual diaphragm vacuum advance units
3. Testing the temperature sensing distributor control valve

E. Test

F. Answers to test

II. References

1. Ethyl Technical Notes. Controlling Exhaust Emissions, 1777 S. Bellaire, Denver, Colorado.
2. Gargano Promotions. Vehicle Emission Control, 12824 West Seven Mile Road, Detroit, Mich. 48235, Gargano Promotions (1973).
3. Glenn, Harold T. Glenn's Emission Control Systems, Chicago, Ill., Henry Regnery Co., (1972).
4. Henein, N. A. and Patterson, D. J. Emissions From Combustion Engines and Their Control, Ann Arbor Science Publications, Inc., Ann Arbor, Mich., (1972).
5. Springer, G. S. and Patterson, D. J. Engine Emission Pollutant Formation and Measurement, Plenum Press, 227 W. 17th Street, New York, N. Y. (1973).

IGNITION TIMING SYSTEMS

UNIT 8

INFORMATION SHEET

- I. PURPOSE OF IGNITION TIMING SYSTEMS - To extend timing control and improve combustion by:
 - A. Retarding the spark at idle where sufficient time is available for combustion to occur due to low engine speeds. This also increases exhaust gas temperatures which promotes additional burning of hydrocarbons in the exhaust manifold. Retarded spark at idle also requires a larger throttle opening to obtain the desired idle speed. This results in more air entering during idle, which reduces fuel mixture dilution with exhaust gases and gives better mixing of the air-fuel charge to improve combustion.
 - B. Advancing timing during deceleration to allow sufficient time for the completion of the combustion process when engine speed is high.
- II. PORTED VACUUM ADVANCE SYSTEM - TM-1 - The ported vacuum advance system provides a retarded spark at idle that allows higher exhaust gas temperatures for additional burning of hydrocarbons in the exhaust manifold.
 - A. The vacuum port for the vacuum advance unit is located above the throttle valve.
 - B. During idle or deceleration when the throttle valve is closed no vacuum signal is felt at the vacuum advance unit.
 - C. Under closed throttle conditions the initial spark timing and the centrifugal advance control the spark timing.

- III. DECELERATION VALVE - TM-2 - The deceleration valve advances timing during deceleration to allow a longer time for combustion to occur.
- A. During deceleration when manifold vacuum exceeds 20" Hg, the deceleration valve closes off the ported carburetor vacuum supply to the vacuum advance diaphragm on the distributor.
 - B. The intake manifold vacuum is then ported to the vacuum advance unit to fully advance ignition timing for a few seconds.
 - C. After the vehicle has slowed down and manifold vacuum approaches idle conditions, the deceleration valve switches from intake manifold vacuum to ported carburetor vacuum.
- IV. DUAL DIAPHRAGM VACUUM ADVANCE UNIT - TM-3 - The dual diaphragm vacuum advance unit provides normal spark advance during normal driving and a retarded spark during idle or deceleration conditions.
- A. The dual diaphragm vacuum advance unit consists of a primary or advance diaphragm and a secondary or retard diaphragm.
 - B. The advance diaphragm is connected to the normal vacuum port located above the carburetor throttle valve.
 - C. The retarded side or diaphragm is acted upon by manifold vacuum.
 - D. The primary or advance side of the unit operates in the same manner as a normal vacuum advance unit, as the throttle valves are opened carburetor vacuum is sensed at the advance diaphragm and the timing is advanced.
 - E. When the throttle valve is closed, during idle or deceleration, the normal vacuum port is closed off and the retard side of the unit receives a manifold vacuum signal that retards the timing.
- NOTE: The dual diaphragm vacuum advance may be used with a deceleration valve to provide maximum spark retard at idle and maximum vacuum advance during deceleration.

- V. TEMPERATURE SENSING DISTRIBUTOR CONTROL VALVE - TM-4, TM-5 - The temperature sensing distributor control valve or thermostatic vacuum switch (TVS) controls the source of vacuum to the dual diaphragm vacuum advance unit to advance ignition timing thus preventing overheating when the engine is allowed to idle for a long period of time.
- A. As engine coolant temperature exceeds approximately 103°C(220°F), the temperature sensing portion of the thermostatic vacuum switch causes the check ball to move up.
 - B. When the check ball is in the "up" position, it blocks off the ported vacuum supply and at the same time allows full manifold vacuum to be directed to the advance side of the dual diaphragm vacuum advance unit.
 - C. This increase in the spark advance causes the engine to speed up.
 - D. The increased engine speed results in increased coolant flow and fan speed which lowers the coolant temperature.
 - E. When coolant temperatures are reduced to a safe temperature, the temperature sensing portion of the thermostatic vacuum switch moves down and spring pressure and manifold vacuum seat the check ball. This shuts off the full manifold vacuum to the advance diaphragm and reopens the ported vacuum source to the advance diaphragm.

PORTED VACUUM ADVANCE

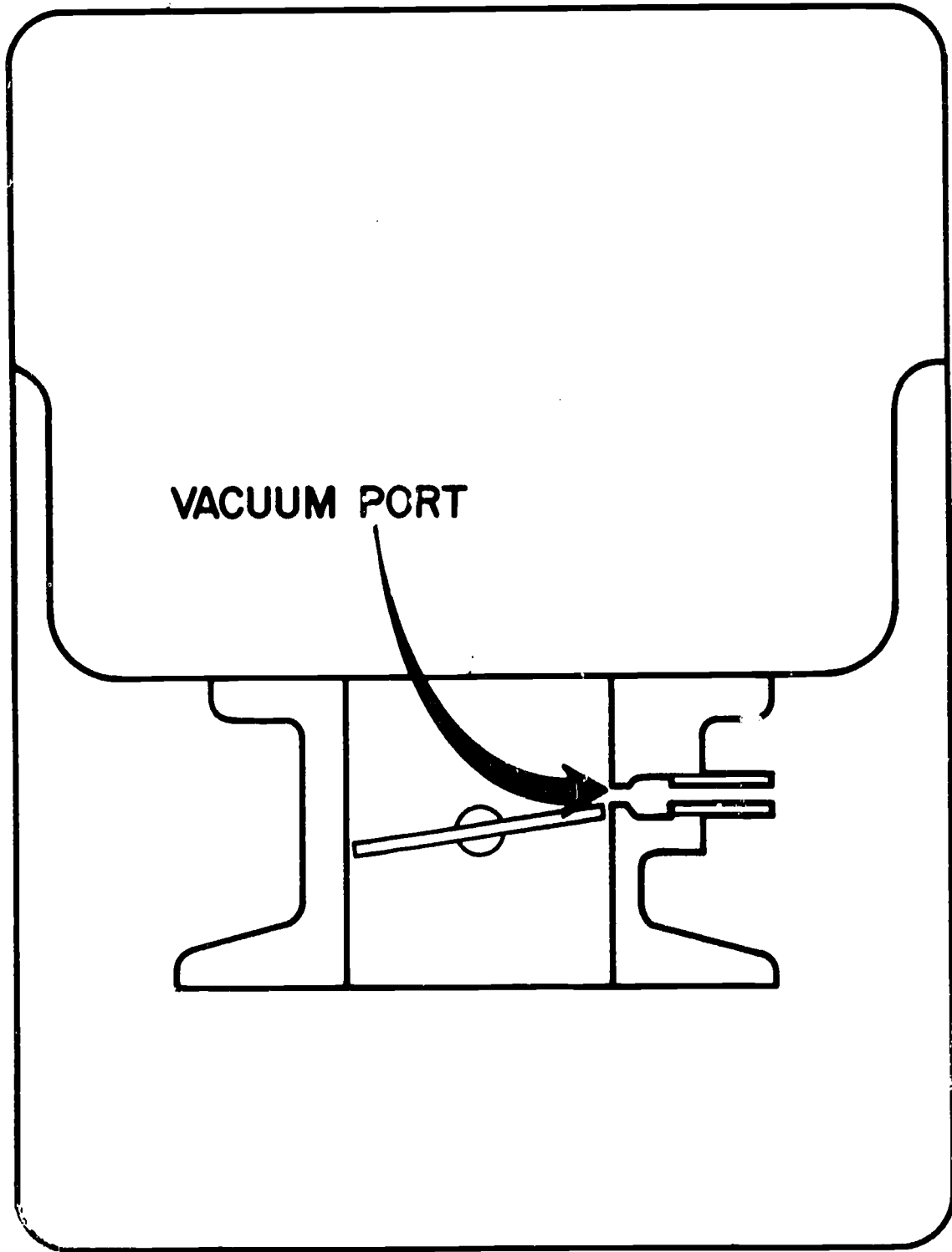

DECELERATION VALVE OPERATION

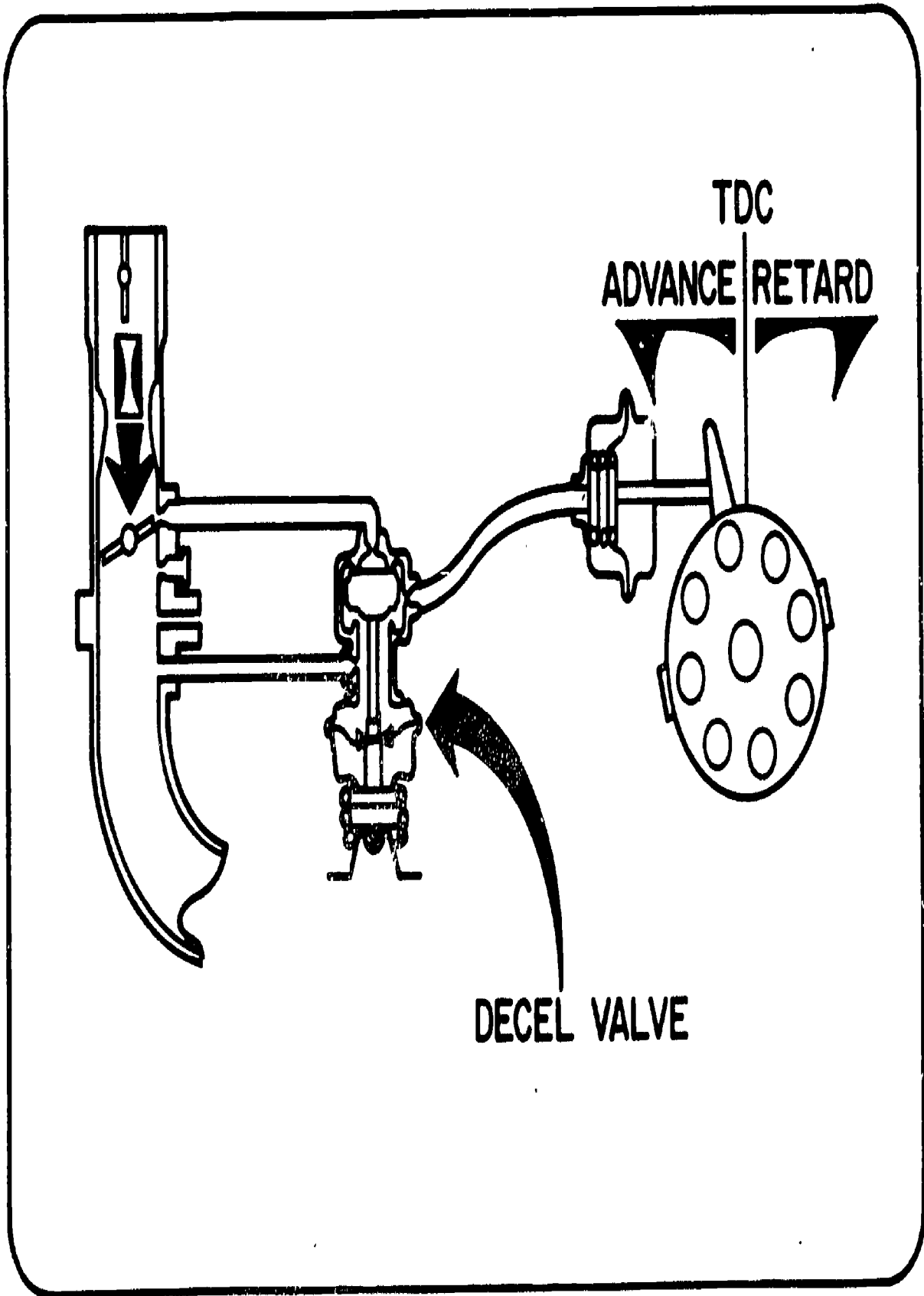

DUAL DIAPHRAGM VACUUM ADVANCE UNIT & OPERATION

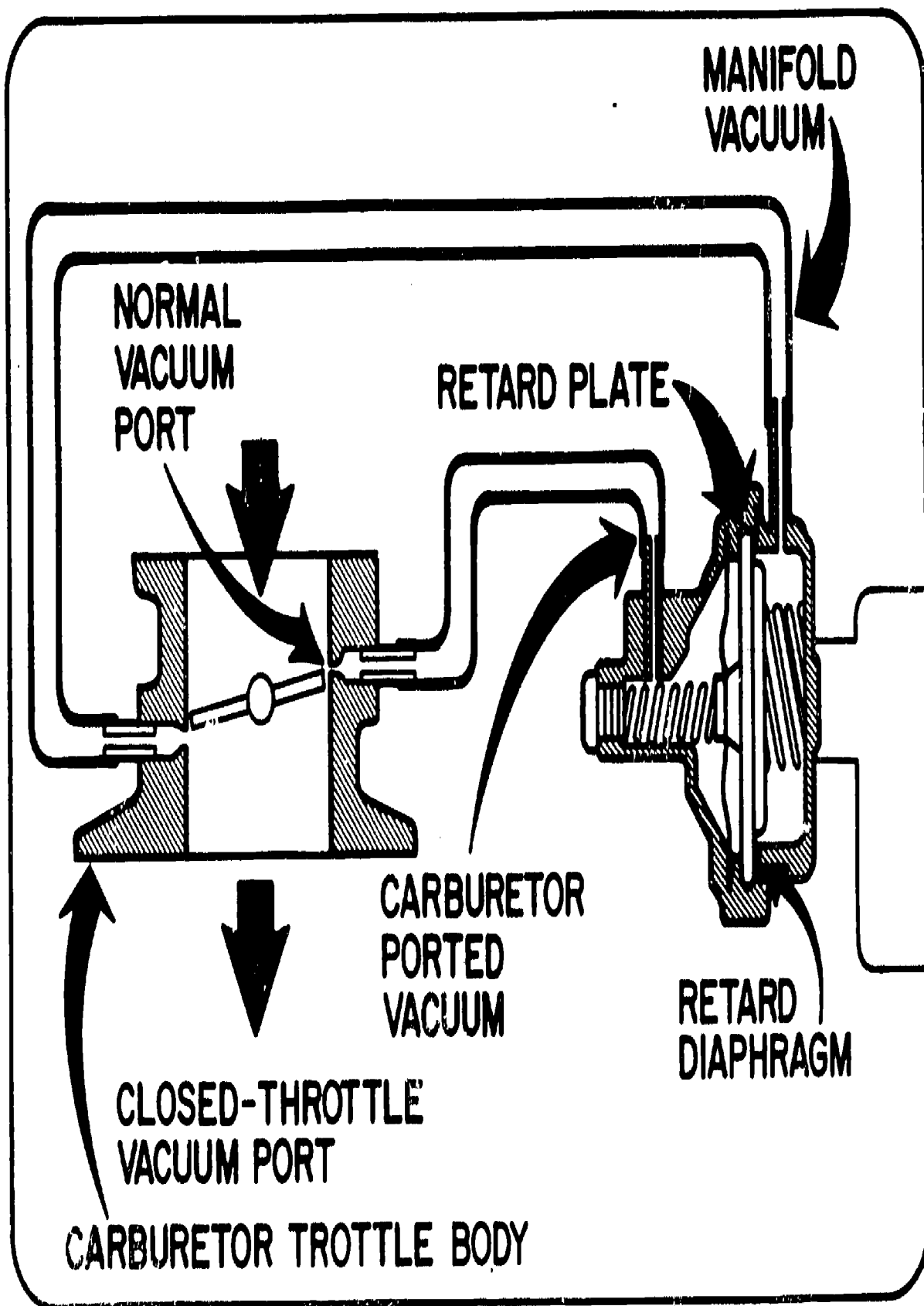

TM-3

TEMPERATURE SENSING DISTRIBUTOR CONTROL VALVE

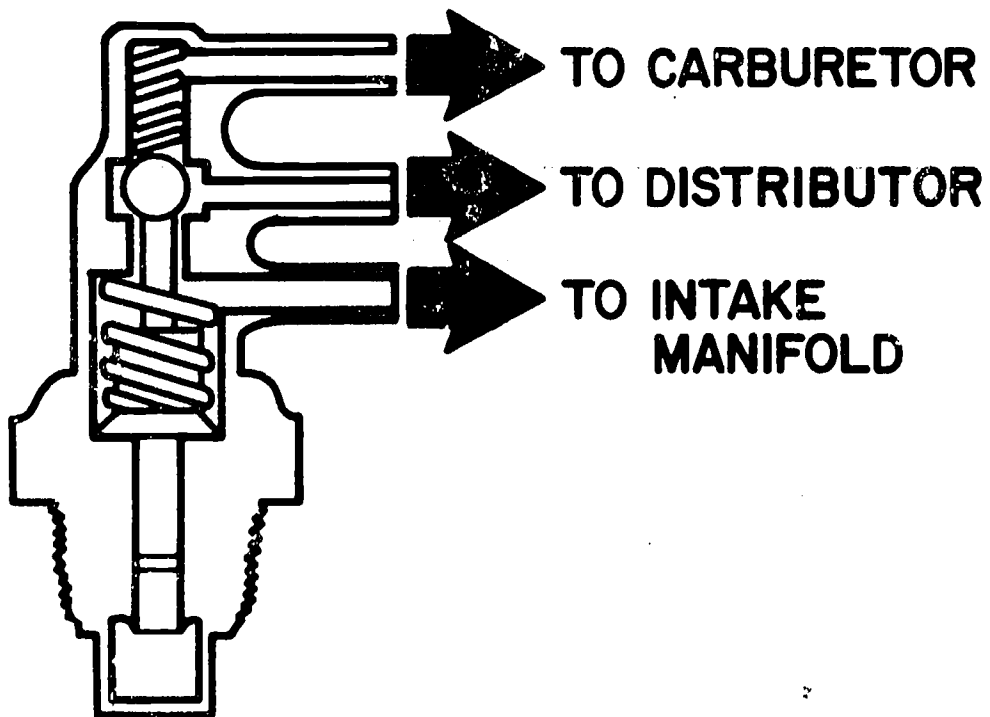

145

TM-4

TEMPERATURE SENSING DISTRIBUTOR CONTROL VALVE OPERATION

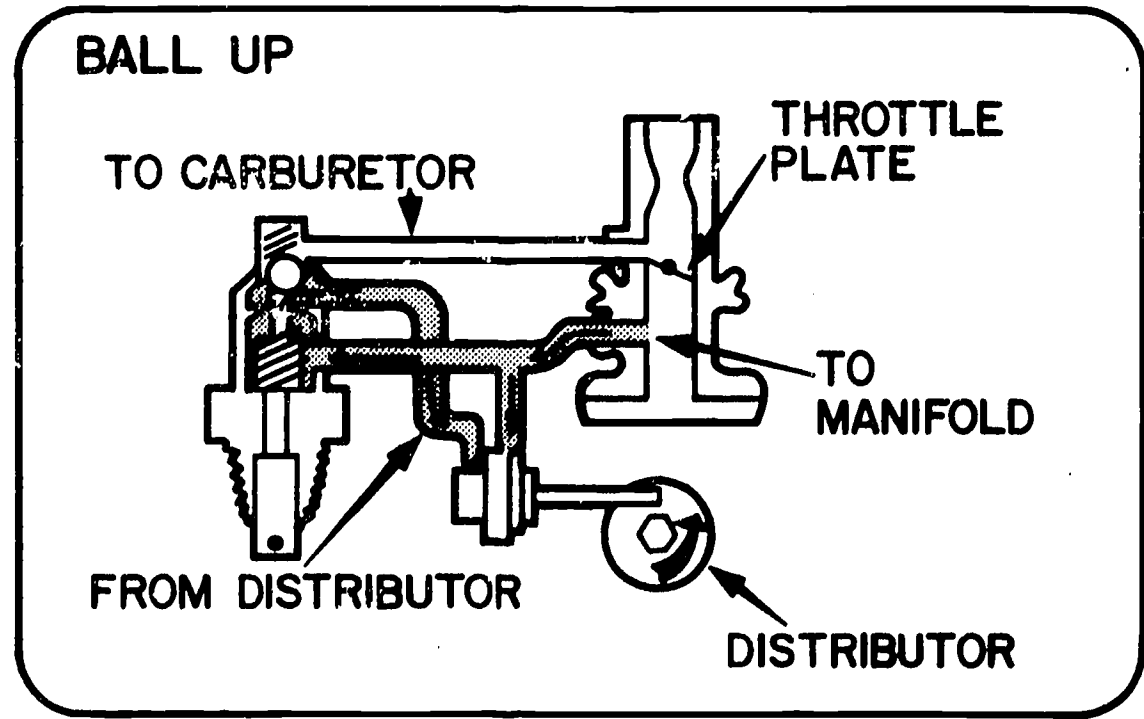
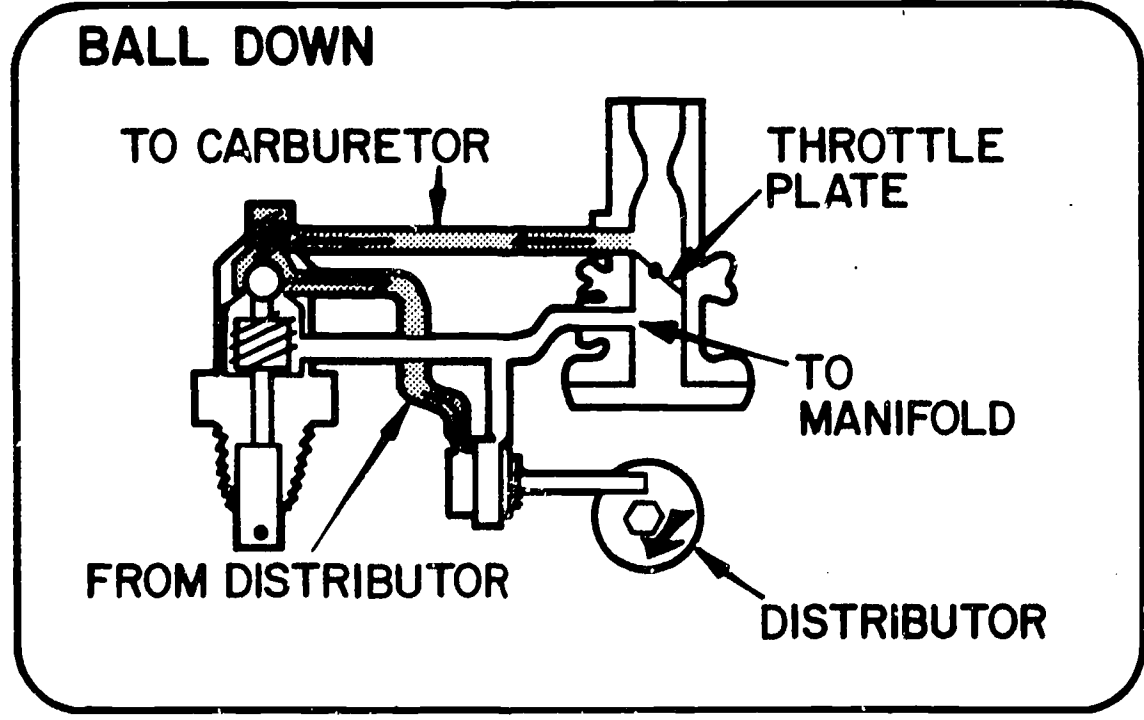

IGNITION TIMING SYSTEMS

UNIT 8

JOB SHEET #1 - TESTING THE DECELERATION VALVE

I. Tools required

- A. Tachometer
- B. Vacuum gauge
- C. Timing light

II. Procedure

- A. Inspect all hose connections for looseness.
- B. Check for hardened or cracked vacuum hoses.
- C. Hook up tachometer.
- D. Connect vacuum gauge to distributor vacuum advance line.
- E. With transmission in neutral and parking brake set, start engine and allow it to come to normal operating temperature.

NOTE: If carburetor dashpot is present, insure the dashpot rod is not in contact with the throttle lever.

- F. Check distributor vacuum reading, it should be below 6" Hg at idle.
- G. Set initial timing and adjust carburetor for specified idle speed and air-fuel ratio.
- H. Increase engine speed to 2000 rpm and maintain for at least 5 seconds.
- I. Release throttle and observe vacuum gauge. The reading should increase to above 16" Hg and remain there for a minimum of 1 second and should not take more than 3 seconds to fall below 6" Hg.
- J. If the deceleration valve is not within the above limits, remove the cap on the deceleration valve.

K. Turning the adjusting screw counter-clockwise will increase the time the distributor vacuum will remain above 6" Hg after releasing the throttle.

NOTE: Complete one turn of the adjusting screw will change the vacuum setting by 1/2" Hg.

L. If the valve cannot be adjusted, replace it.

NOTE: These are BASIC PROCEDURES. Check the manufacturers service shop manual or technical manual for exact procedures and specifications for each make and model.

JOB SHEET #2 - TESTING THE DUAL DIAPHRAGM VACUUM ADVANCE UNIT

I. Tools required

Tachometer

II. Procedure

- A. Inspect all hose connections for looseness.
- B. Check for hardened or cracked vacuum hoses.
- C. With transmission in neutral and parking brake set, start engine and allow it to come to normal operating temperature.
- D. Disconnect the vacuum hoses to the advance and retard connections on the unit.

NOTE: The connection closest to the distributor is the retard diaphragm section and is connected to intake manifold vacuum. The outer connection is the advance diaphragm section and is connected to ported vacuum source.

- E. Set engine up at fast idle speed and note tachometer reading.
- F. Connect the ported vacuum hose to the outer connection. The engine rpm should increase.
- G. Reset engine idle speed to specified hot idle rpm.
- H. Connect manifold vacuum hose to retard diaphragm connection. Engine speed should decrease.

NOTE: These are BASIC PROCEDURES. Check the manufacturers service shop manual or technical manual for exact procedures and specifications for each make and model.

JOB SHEET #3 - TEST TEMPERATURE SENSING DISTRIBUTOR CONTROL VALVE

I. Tools required

Tachometer

II. Procedure

- A. Inspect all hose connections for looseness.
- B. Check for cracked vacuum hoses.
- C. Connect tachometer.
- D. With transmission in neutral and parking brake set, start engine and allow it to come to normal operating temperature.
- E. Insure choke is in the vertical position and the engine is not overheated.
- F. Note the engine rpm.
- G. Disconnect vacuum hose from the intake manifold source at the temperature sensing valve and clamp it shut.
- H. If the engine rpm does not change the valve is good to this point. If idle speed drops 100 rpm or more, replace the valve.
- I. Reconnect the vacuum hose to the temperature sensing valve.
- J. Check that the correct radiator cap is installed and the cooling system antifreeze is up to specifications.
- K. Cover the radiator to reduce air flow enough to cause a high temperature condition.
- L. By the time the red temperature warning light comes on, the engine speed should have increased by at least 100 rpm. If the speed increase occurs the temperature sensing valve is operating properly.

NOTE: These are BASIC PROCEDURES. Check the manufacturers service shop manual or technical manual for exact procedures and specifications for each make and model.

IGNITION TIMING SYSTEMS

UNIT 8

T E S T

1. What is the purpose of ignition timing systems?

2. What is the purpose of the ported vacuum advance system?

3. Discuss the operation of the ported vacuum advance system.

4. What is the purpose of the deceleration valve?

5. Discuss the operation of the deceleration valve.

6. What is the purpose of the dual diaphragm vacuum advance unit?

7. Discuss the operation of the dual diaphragm vacuum advance unit.

8. What is the purpose of the temperature sensing distributor control valve?

9. Discuss the operation of the temperature sensing distributor control valve.

10. The student should demonstrate the ability to perform the following jobs to the satisfaction of the instructor:

a. Test deceleration control valve operation.

b. Test dual diaphragm vacuum advance unit.

c. Test temperature sensing distributor control valve.

IGNITION TIMING SYSTEMS

UNIT 8

ANSWERS TO TEST

1. What is the purpose of ignition timing systems? To extend timing control and improve combustion by:

a. Retarding spark at idle where sufficient time is available for combustion to occur due to low piston speeds.

(Main Points)

1. Increases exhaust gas temperatures in exhaust manifold and further burns hydrocarbons.
2. Requires larger throttle opening to obtain specified idle rpm. This reduces air-fuel mixture dilution with exhaust gas and results in improved combustion.

b. Advancing timing during deceleration to allow more time for the completion of the combustion process when piston speeds are high.

2. What is the purpose of the ported vacuum advance system?

Provides a retarded spark at idle which leads to further burning of hydrocarbons in the exhaust manifold because of higher gas temperatures.

3. Discuss the operation of the ported vacuum advance system.

(Main Points)

- a. Vacuum port located above throttle valve.
- b. During idle or deceleration no vacuum advance.
- c. Initial spark timing and centrifugal advance controls spark under closed throttle conditions.

4. What is the purpose of the deceleration valve?

To advance timing during deceleration and allow more time for combustion to occur.

5. Discuss the operation of the deceleration valve.
 - a. When manifold vacuum exceeds 20" Hg during deceleration, the deceleration valve shuts off the ported vacuum supply to the vacuum advance unit.
 - b. Intake manifold vacuum is then ported to the vacuum advance unit to fully advance timing for a few seconds.
 - c. When idle conditions are approached, the deceleration valve switches from manifold vacuum to ported carburetor vacuum.
 - d. Basic timing controls ignition during idle.
6. What is the purpose of the dual diaphragm vacuum advance unit?
Provide normal spark advance during normal driving and retarded spark during idle or deceleration.
7. Discuss the operation of the dual diaphragm vacuum advance unit.
 - a. Advance diaphragm is connected to a ported vacuum supply, the retard diaphragm is connected to a source of manifold vacuum.
 - b. As the throttle valves are opened the ported vacuum supply acts on the advance diaphragm and normal vacuum advance takes place.
 - c. When the throttle valve is closed, there is no ported vacuum supply to the advance diaphragm but full intake manifold vacuum is applied to the retard diaphragm and spark timing is retarded.
8. What is the purpose of the temperature sensing distributor control valve?
Controls the source of vacuum to the dual diaphragm vacuum advance unit to prevent engine overheating when the engine is left idling for long periods of time.

9. Discuss the operation of the temperature sensing distributor control valve.
- a. When engine coolant temperature exceeds approximately 103°C (200°F), the check ball is moved upward blocking off the ported vacuum supply to the advance diaphragm.
 - b. At the same time full manifold vacuum is directed to the advance diaphragm.
 - c. The increase in spark advance results in increased engine speed, coolant flow and fan speed and lowers engine coolant temperature.
 - d. When temperature is lowered to a safe valve, the check ball is moved down, blocking off intake manifold vacuum and redirecting ported carburetor vacuum to the advance diaphragm.

TRANSMISSION CONTROLLED SPARK SYSTEM

UNIT 9

TERMINAL OBJECTIVE

After completion of this unit the student will be able to explain the purpose of the transmission controlled spark (TCS) system and explain the purpose of transmission controlled spark system components. The student will be able to perform a functional TCS system check.

This will be evidenced through demonstration and scoring 85% minimum on the unit test.

SPECIFIC OBJECTIVES

After completion of this unit the student will be able to:

1. Write the purpose of the transmission controlled spark system.
2. Write the purpose of each of the components in the transmission controlled spark system.
3. Identify each of the components in the TCS system.
4. Discuss in writing the operation of the TCS system.
5. Demonstrate the ability to:

Perform a functional TCS system check.

TRANSMISSION CONTROLLED SPARK SYSTEM

UNIT 9

SUGGESTED ACTIVITIES

I. Instructor

- A. Provide students with objective sheet
- B. Provide students with information and job sheet
- C. Make transparencies
- D. Discuss terminal and specific objectives
- E. Discuss information sheet
- F. Demonstrate and discuss procedures outlined on job sheets

NOTE: There are many variations in TCS systems, it is suggested the instructor make up more specific job sheets depending on the makes and models of vehicles available to them.

G. Give test

II. Student

- A. Read objective sheet
- B. Study information sheet
- C. Demonstrate ability to accomplish procedures
- D. Take test

INSTRUCTIONAL MATERIALS

I. Included in this unit:

- A. Objective sheet
- B. Information sheet
- C. Transparency masters

9-TM-1 - TCS System Schematic - Engine Off

9-TM-2 - TCS System - Cold Override and Time Relay Energized

- 9-TM-3 - TCS System - Low Gear Operation
- 9-TM-4 - TCS System - High Gear Operation
- 9-TM-5 - Vacuum Advance Diagram TCS System

D. Test

E. Answers to test

II. References

1. 1973 Chevrolet Service Manual (contact local dealer).
2. Echlin Manufacturing Co. Echlin Service Bulletin, March 1969-70; Feb. 1971.
3. Gargano Promotions. Vehicle Emission Control, 12824 West Seven Mile Road, Detroit, Mich. 48235, Gargano Promotions (1973).
4. Glenn, Harold T. Glenn's Emission Control Systems, Chicago, Ill., Henry Regnery Co., (1972).

TRANSMISSION CONTROLLED SPARK SYSTEM

UNIT 9

INFORMATION SHEET

- I. PURPOSE OF THE TRANSMISSION CONTROLLED SPARK SYSTEM - To extend the advantages of retarded timing and reduce emissions by the elimination of distributor vacuum advance in all gears except high gear.
- II. COMPONENTS OF THE TRANSMISSION CONTROLLED SPARK SYSTEM - TM-1
- A. Temperature Switch - Senses cooling system temperature and allows vacuum advance when cooling system temperature is below 33°C(93°F). Above 33°C(93°F) the switch contacts are open and will not allow vacuum advance.
- NOTE: There are several different temperature switches. Refer to proper service or shop manual for vehicle application and specifications.
- B. Time Relay - Allows the vacuum advance solenoid to energize for approximately 20 seconds after the ignition switch is turned on allowing vacuum to the distributor vacuum advance unit.
- C. Transmission Switch - Remains open in all forward gears except high gear. When in high gear the switch is closed and distributor vacuum advance is allowed. The switch is mechanically controlled on standard transmissions and hydraulically controlled on automatic transmissions.
- D. Idle Stop Solenoid - Prevents "dieseling" by allowing the throttle valves to close completely when the ignition switch is turned off and provides a predetermined throttle opening when energized.

- E. Vacuum Advance Solenoid Valve - A two position valve that when energized allows the vacuum supply to reach the vacuum advance unit. When deenergized the vacuum supply is shut off and the distributor vacuum advance unit is vented to the clean air vent. This prevents the vacuum advance unit from being locked in an advanced position.

III. OPERATION OF THE TCS SYSTEM - TM-1

- A. With the engine off and cold, the idle stop solenoid is deenergized and the solenoid plunger is retracted, the temperature switch is in the closed position, the time relay is in the closed position, the transmission switch is in the open position and the vacuum advance solenoid is deenergized.
- B. When the ignition switch is turned on there are two circuits for energizing the vacuum advance solenoid and providing vacuum advance - TM-2.
1. Through the time relay which will remain closed for 20 seconds after the ignition switch is turned on.
 2. Through the temperature switch which will remain closed as long as coolant temperature is below 33°C(93°F).
- C. When approximately 20 seconds have elapsed the time relay will open, breaking the time relay circuit and deenergizing the vacuum advance solenoid.
- D. When engine coolant temperature reaches 33°C(93°F) the temperature switch contacts will open breaking the cold override circuit and deenergizing the vacuum advance solenoid.

- E. While the vehicle is moving forward in the lower gears the transmission switch contacts are open and there are no complete circuits for energizing the vacuum advance solenoid. This prevents vacuum from reaching the vacuum advance unit and timing remains retarded - TM-3.
- F. When the transmission is shifted into high gear, the transmission switch contacts close, completing the circuit and energizing the vacuum advance solenoid. This allows vacuum to the vacuum advance unit and allows normal vacuum advance - TM-4.

TCS SYSTEM SCHEMATIC - ENGINE OFF

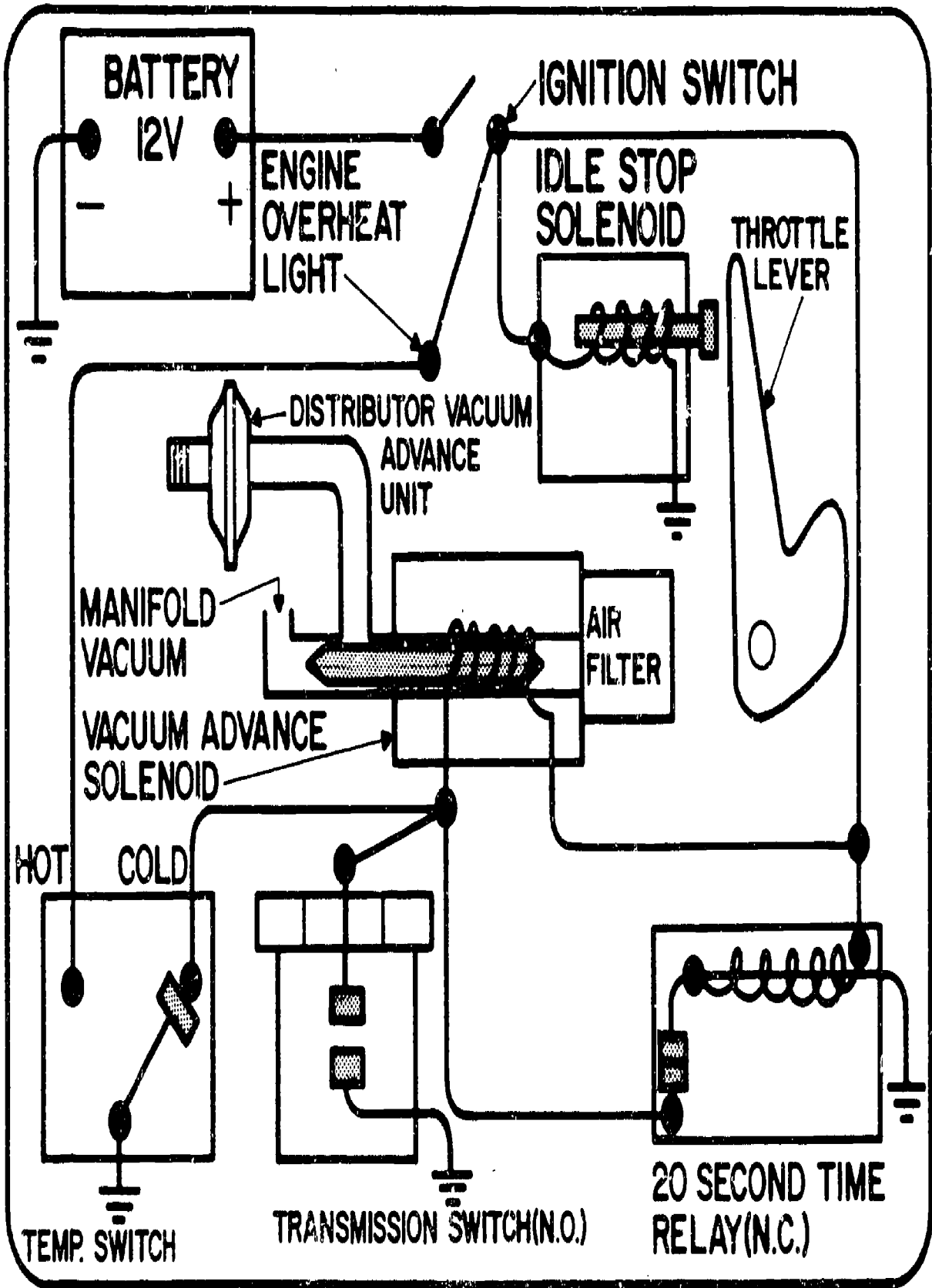

TCS SYSTEM - COLD OVERRIDE AND TIME RELAY ENERGIZED

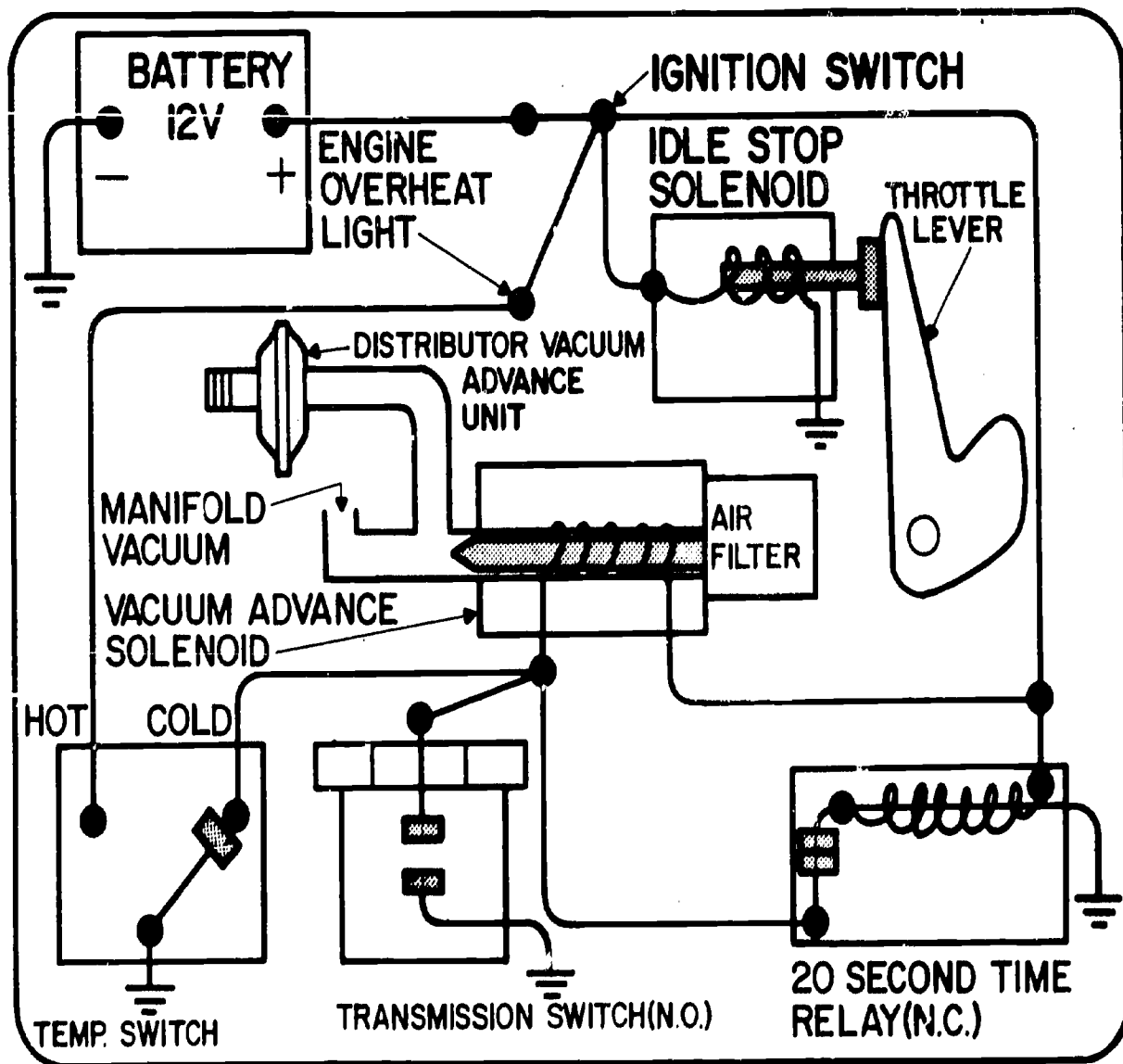

205

TCS SYSTEM - LOW GEAR OPERATION

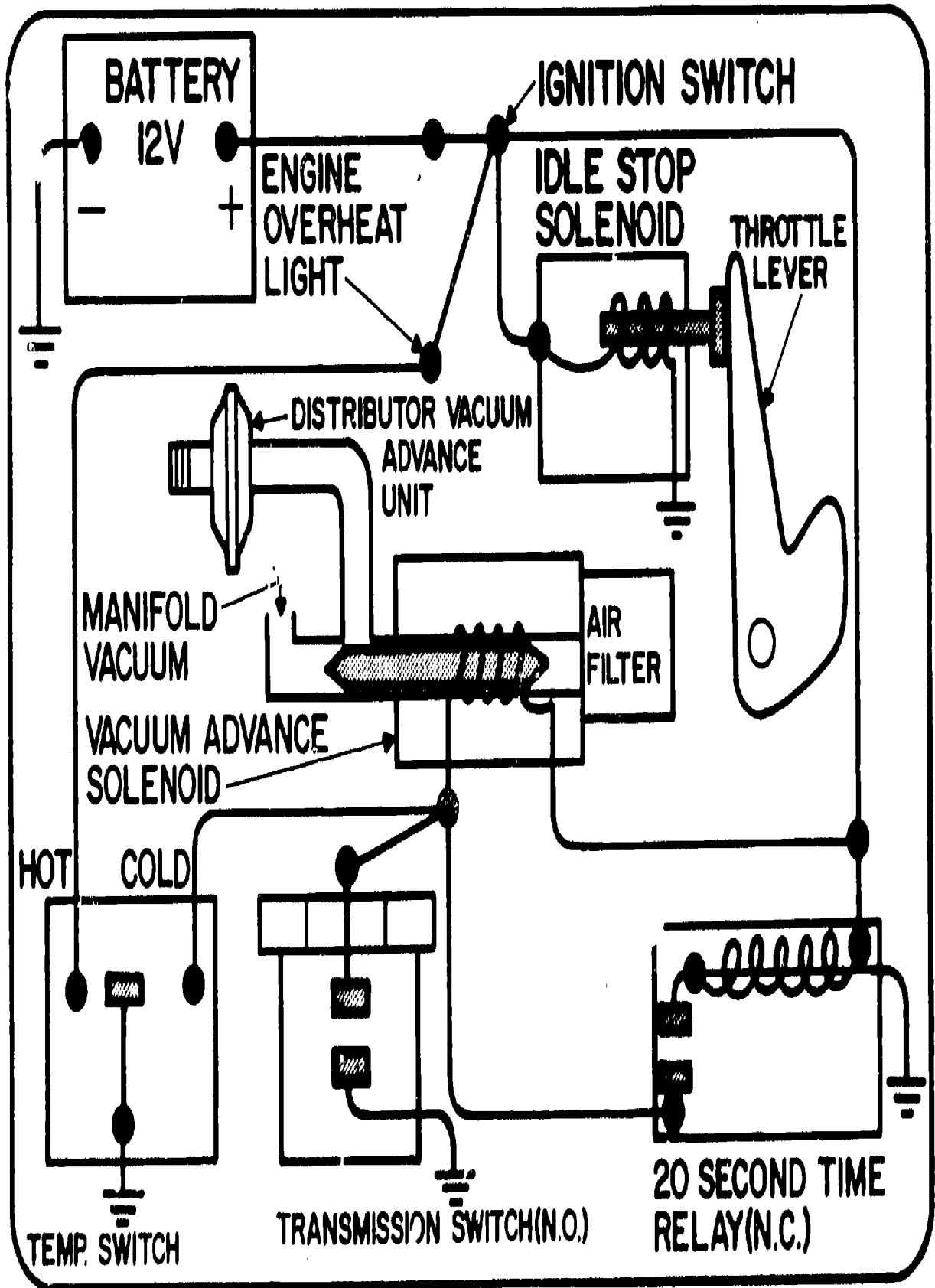

TCS SYSTEM - HIGH GEAR OPERATION

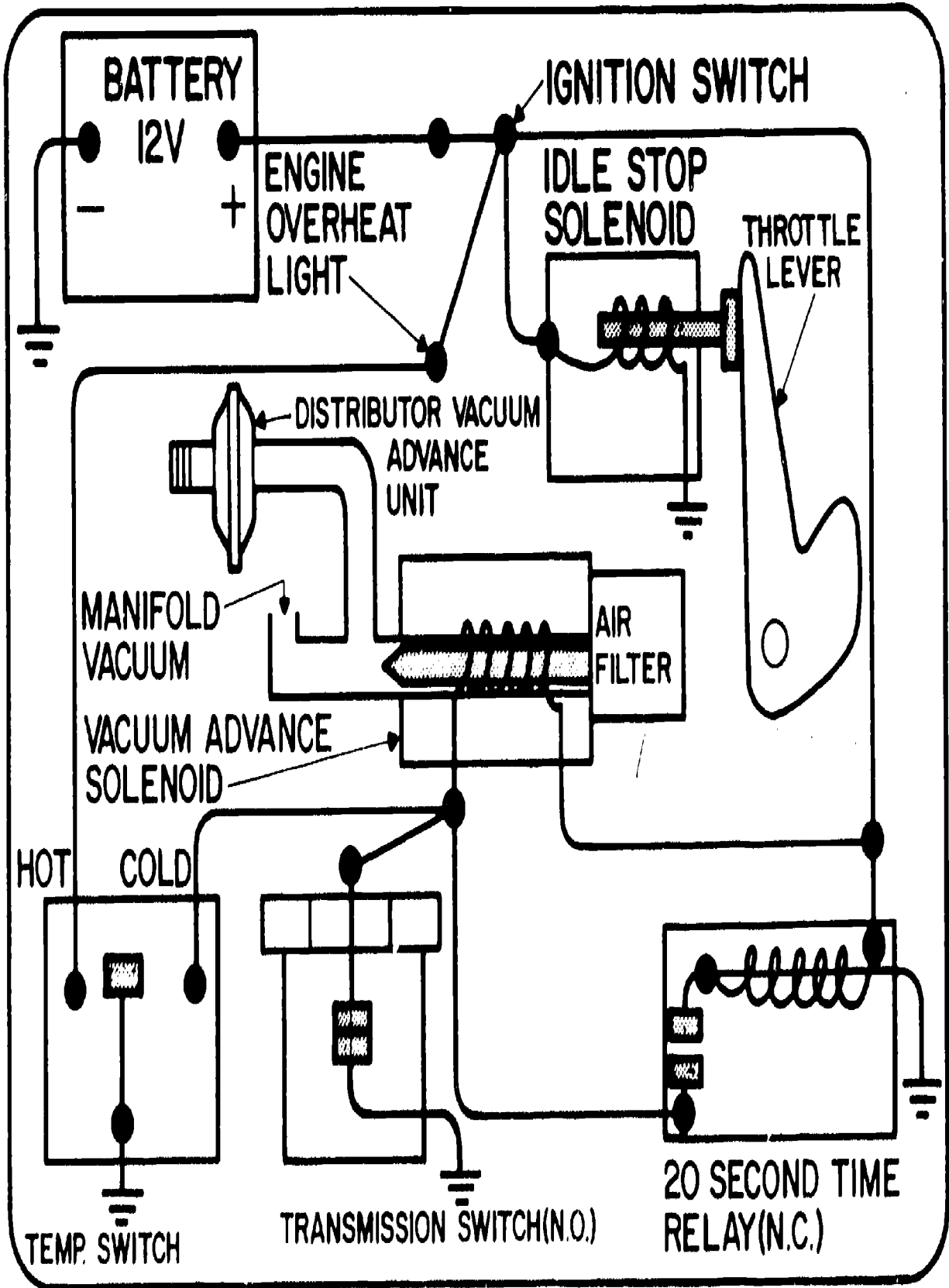

TM-4

VACUUM ADVANCE DIAGRAM TCS SYSTEM

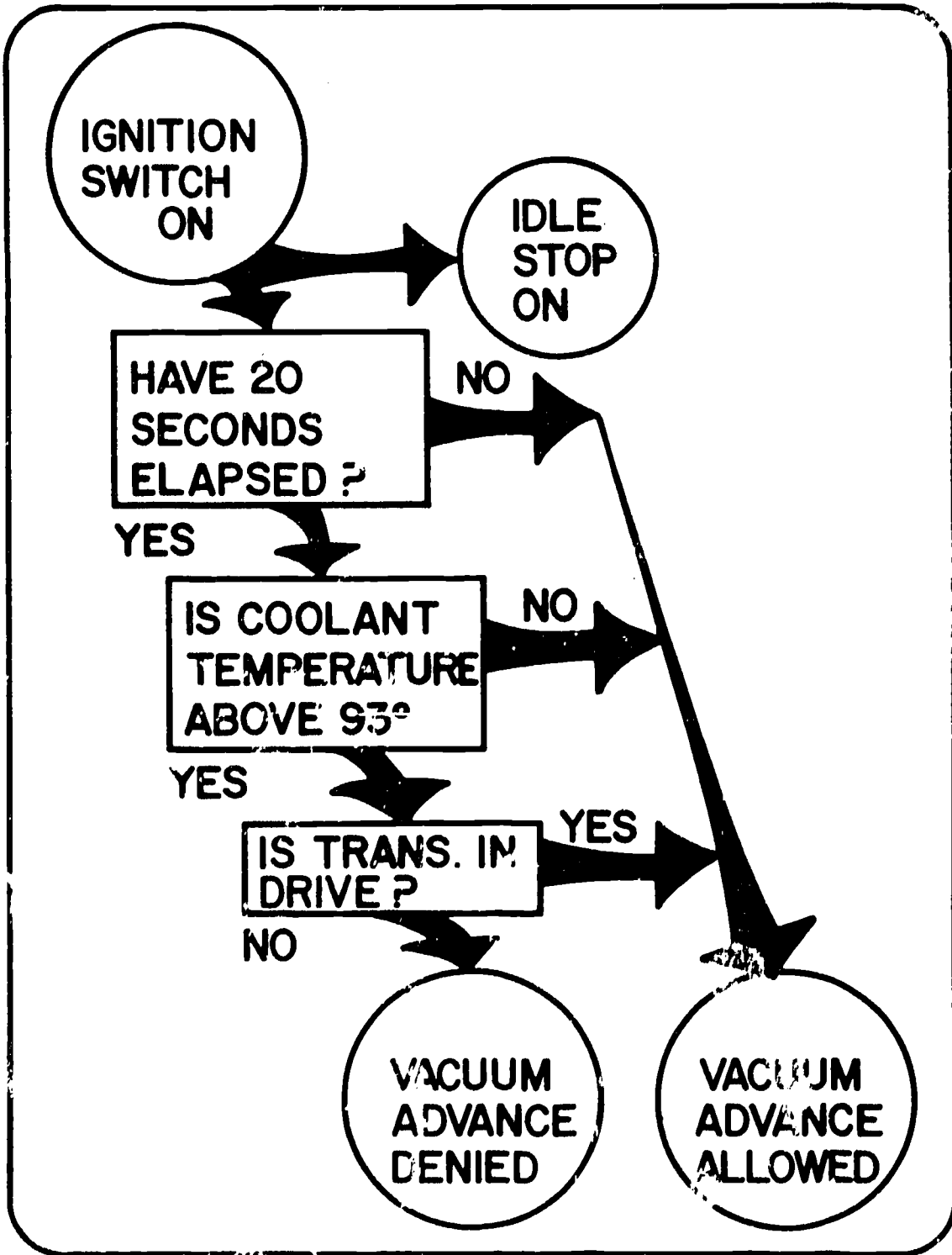

TRANSMISSION CONTROLLED SPARK SYSTEM

UNIT 9

JOB SHEET #1 - FUNCTIONAL TEST OF TCS SYSTEM

I. Tools required

- A. Timing light
- B. Tachometer
- C. Wheel blocks

II. Procedure - (Turbohydromatic Transmissions)

- A. Block one wheel both for the forward position and reverse position (turbohydromatic transmission).
- B. Connect timing light and tachometer.
- C. With transmission in neutral and parking brake set start engine and allow it to come to normal operating temperature.
- D. Move transmission selector into drive.
- E. Increase engine rpm to approximately 1000 rpm.
- F. Check timing - there should be no vacuum advance.
- G. Shift transmission into reverse.
- H. Check timing - there should be full vacuum advance.

NOTE: These are BASIC PROCEDURES. Check the manufacturers service shop manual or technical manual for exact procedures and specifications for each make and model.

TRANSMISSION CONTROLLED SPARK SYSTEM

UNIT 9

T E S T

1. What is the purpose of the transmission controlled spark (TCS) system?

2. Write the purpose of each of the components in the TCS system.

a.

b.

c.

d.

e.

3. Identify each of the components in the TCS system.

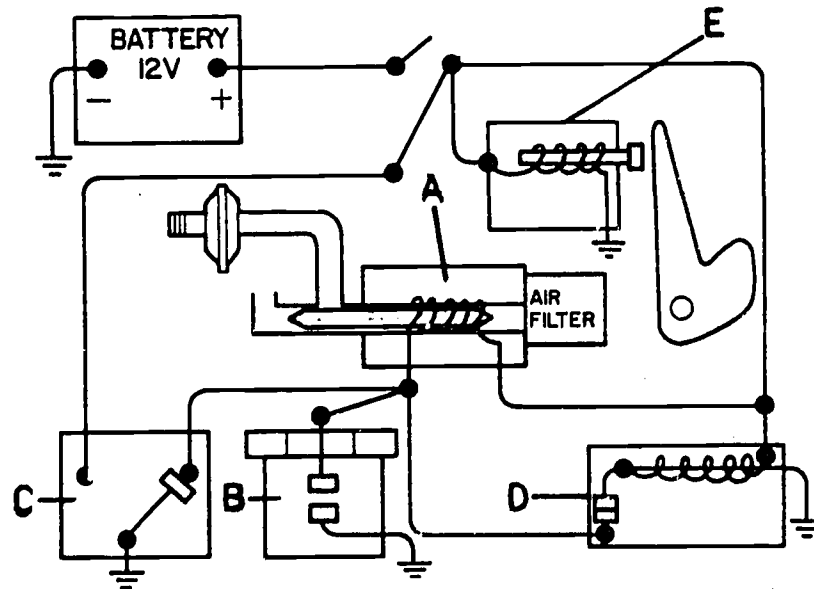

- a.
- b.
- c.
- d.
- e.

4. Discuss in writing TCS system operation.

5. The student should demonstrate the ability to perform the following job to the satisfaction of the instructor:

Perform a functional TCS system check.

TRANSMISSION CONTROLLED SPARK SYSTEM

UNIT 9

ANSWERS TO TEST

1. What is the purpose of the transmission controlled spark (TCS) system?
To extend the advantages of retarded timing and reduce emissions by the elimination of vacuum advance in all gears except high gear.
2. Write the purpose of each of the components in the TCS system.
 - a. Temperature Switch - To sense cooling system temperature and allow vacuum advance when temperature is below 33°C(93°F).
 - b. Time Relay - Allow vacuum advance solenoid to be energized for approximately 20 seconds after ignition switch is turned on.
 - c. Transmission Switch - Remain open and prevent vacuum advance in all gears except high gear.
 - d. Idle Stop Solenoid - Prevent dieseling by allowing the throttle valves to close completely when deenergized and when energized provide a predetermined throttle opening.
 - e. Vacuum Advance Solenoid Valve - A two-position valve that when energized allows vacuum to reach the vacuum advance unit. When deenergized, the vacuum supply is shut off and the distributor vacuum advance unit is vented to atmosphere.
3. Identify each of the components in the TCS system.
 - a. Vacuum advance solenoid valve
 - b. Transmission switch
 - c. Temperature switch
 - d. Time relay
 - e. Idle stop solenoid

4. Discuss in writing TCS system operation.
 - a. When a cold engine is started, two circuits are completed for energizing the vacuum advance solenoid valve:
 1. The temperature switch completes one circuit.
 2. The time relay completes the other for 20 seconds after the ignition is turned on.
 - b. After 20 seconds the time relay circuit deenergizes and when coolant temperature reaches 33°C(93°F) the contacts open deenergizing that circuit. The vacuum advance solenoid is then deenergized and no vacuum is supplied to the vacuum advance unit.
 - c. When the vehicle moves forward in the lower gears the transmission switch contacts are open and the vacuum advance solenoid is deenergized.
 - d. When the transmission is shifted into high gear the transmission switch contacts close, energizing the vacuum advance solenoid. This allows vacuum to be supplied to the vacuum advance diaphragm and permits normal vacuum advance.

ELECTRONIC SPARK CONTROL SYSTEM

UNIT 10

TERMINAL OBJECTIVE

After completion of this unit the student will be able to explain the purpose of the electronic spark control (ESC) system and explain the purpose of electronic spark control system components. The student will be able to perform a functional ESC system check.

This will be evidenced through demonstration and scoring 85% minimum on the unit test.

SPECIFIC OBJECTIVES

After completion of this unit the student will be able to:

1. Write the purpose of the electronic spark control system.
2. Write the purpose of each component in the electronic spark control system.
3. Identify each of the components in the ESC system.
4. Discuss in writing the operation of the ESC system.
5. Demonstrate the ability to:

Perform a functional ESC system test.

ELECTRONIC SPARK CONTROL SYSTEM

UNIT 10

SUGGESTED ACTIVITIES

I. Instructor

- A. Provide students with objective sheet
- B. Provide students with information and job sheets
- C. Make transparencies
- D. Discuss terminal and specific objectives
- E. Discuss information sheet
- F. Demonstrate and discuss procedures outlined on job sheets

NOTE: Only an operational test is included in this unit. Further system checks should be conducted, but will require a shop service manual for the specific make and model to be tested.

G. Give test

II. Student

- A. Read objective sheet
- B. Study information sheet
- C. Demonstrate ability to accomplish procedures
- D. Take test

INSTRUCTIONAL MATERIALS

I. Included in this unit:

- A. Objective sheet
- B. Information sheets
- C. Transparency masters
 - 10-TM-1 - ESC System
- D. Test
- E. Answers to test

II. References

1. Gargano Promotions. Vehicle Emission Control, 12824 West Seven Mile Road, Detroit, Mich. 48235, Gargano Promotions (1973).
2. Glenn, Harold T. Glenn's Emission Control Systems, Chicago, Ill., Henry Regnery Co., (1972).

ELECTRONIC SPARK CONTROL SYSTEM

UNIT 10

INFORMATION SHEET

- I. PURPOSE OF ELECTRONIC SPARK CONTROL SYSTEM - To reduce hydrocarbons and carbon monoxide and NO_x emissions by operating with a retarded spark when outside air temperature is above 15°C (60°F) and the vehicle is moving below a specified road speed.
- II. COMPONENTS OF THE ELECTRONIC SPARK CONTROL SYSTEM - T-1
 - A. Solenoid Vacuum Control Valve - Located in the vacuum line between the carburetor and the distributor vacuum advance unit. The valve is normally open allowing vacuum to reach the distributor vacuum advance unit and providing normal vacuum advance. When the ESC is activated, a control signal from the electronic amplifier energizes the vacuum control valve solenoid and blocks vacuum to the distributor.
 - B. Temperature Switch - Located in a door pillar and uses a bimetallic element to sense ambient air temperature. When air temperatures are above 15°C (60°F), the switch closes and energizes the electronic amplifier. At temperatures below 9°C (49°F) the temperature switch opens.
 - C. Speed Sensor - Located in the speedometer cable and is a small generator. As vehicle speed increases the speed sensor generates a voltage signal that is proportional to vehicle speed. This voltage signal is sent to the electronic amplifier and the strength of the signal determines when the electronic amplifier energizes or deenergizes the solenoid in the vacuum control valve.

3.

D. Electronic Amplifier - Is located under the instrument panel and is energized from the temperature switch when temperature is above 15°C(60°F). When the signal from the speed sensor shows no vehicle speed, the electronic amplifier completes the ground circuit to the solenoid in the vacuum control valve, energizing the solenoid and blocking vacuum to the vacuum advance unit. During acceleration at a preset road speed, the vacuum control solenoid will be deenergized and vacuum advance will be allowed.

NOTE: There are several different electronic amplifiers. Each has a different speed cut in setting ranging from 23 mph to 35 mph. Check the shop service manual for exact settings.

111. OPERATION OF THE ESC SYSTEM

- A. When ambient air temperature is below approximately 15°C(60°F), the temperature switch remains open and the ESC system is deenergized.
- B. The vacuum control valve solenoid is deenergized and normal vacuum advance is allowed regardless of road speed.
- C. When ambient air temperatures are above 15°C(60°F), the temperature switch closes and energizes the electronic amplifier.
- D. At road speeds between 0 mph and approximately 35 mph, the signal from the speed sensor, to the electronic amplifier causes the amplifier to energize the vacuum control valve solenoid and block vacuum to the distributor vacuum advance unit which results in retarded spark timing.
- E. When speed exceeds approximately 35 mph, the speed sensor signal causes the electronic amplifier to deenergize the vacuum control valve solenoid and normal vacuum advance occurs.
- F. During deceleration, the vacuum control valve solenoid is energized at approximately 15 mph and vacuum is blocked to the vacuum advance unit on the distributor.

ESC SYSTEM

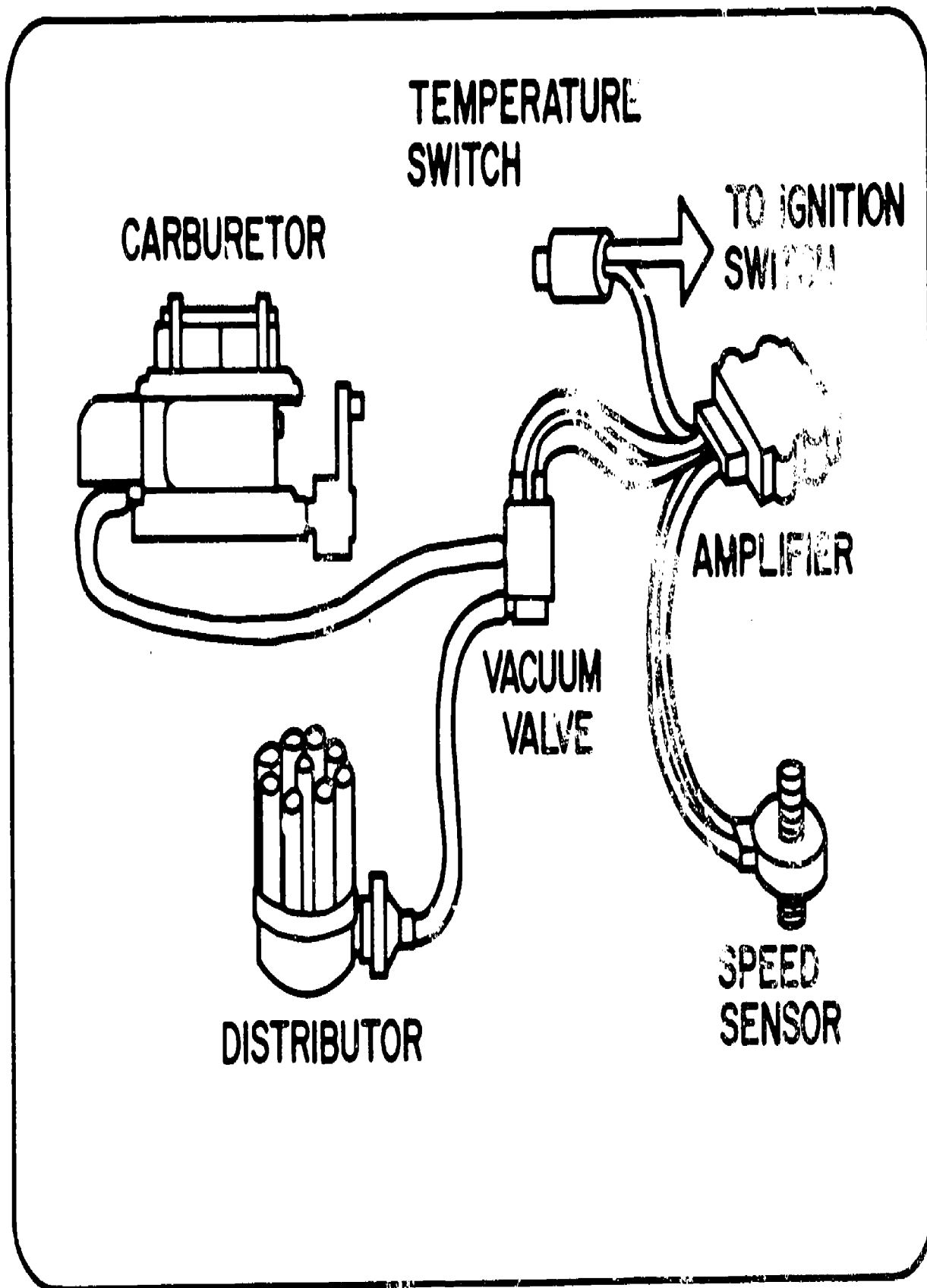

ELECTRONIC SPARK CONTROL SYSTEM

UNIT 10

JOB SHEET #1 - ESC OPERATIONAL TEST

I. Tools required

- A. Vacuum gauge with T fitting
- B. Two safety stands

II. Procedure

- A. Ambient air temperature should be above 18°C(65°F).
- B. Jack up rear wheels and install safety stands.
- C. Connect vacuum gauge at distributor vacuum advance unit.
- D. With the transmission in neutral, start the engine.
 - E. The vacuum gauge should read zero.
- F. Shift the transmission into gear and accelerate slowly to 40 mph.
- G. Somewhere between approximately 21 and 31 mph (depending on amplifier used) the vacuum gauge should read at least 6" Hg.
- H. Slowly start allowing the engine to decelerate.
- I. Somewhere between 31 and 15 mph the vacuum gauge reading should drop to zero.
- J. Place transmission in neutral.
- K. Set engine up on fast idle (approximately 1500 rpm).
- L. Cool the thermal switch to below 90°C(49°F).
- M. The vacuum gauge should have some reading.

NOTE: These are BASIC PROCEDURES. Check the proper manufacturers technical or shop manual for exact procedures for each make and model.

ELECTRONIC SPARK CONTROL SYSTEM

UNIT 10

TEST

1. What is the purpose of the electronic spark control system?

2. Write the purpose of each of the components in the ESC system.
 - a.

 - b.

 - c.

 - d.

3. Identify each of the components in the ESC system.

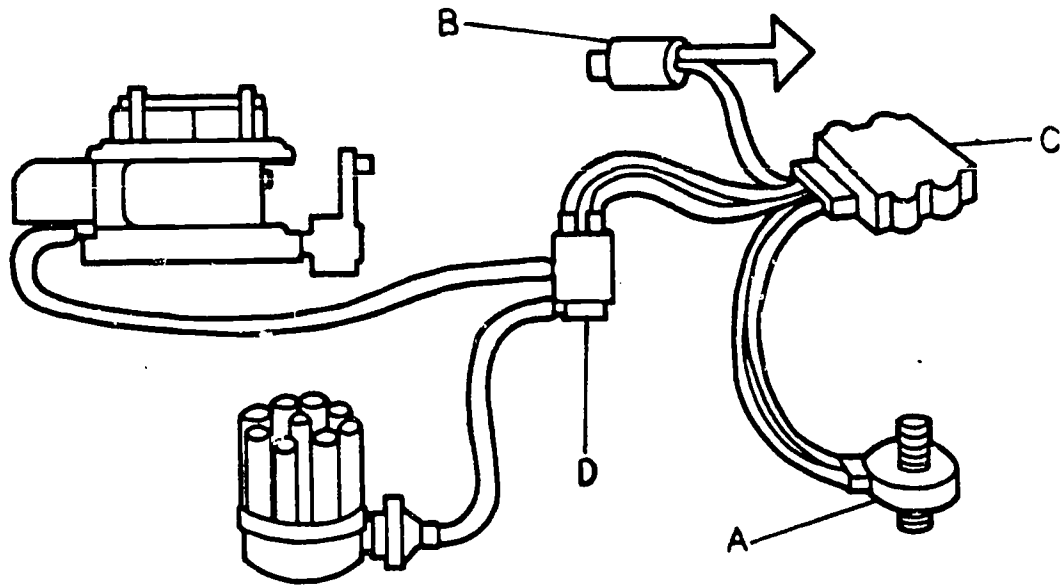

- a.
- b.
- c.
- d.

4. Discuss in writing ESC system operation.

5. The student should demonstrate the ability to perform the following job to the satisfaction of the instructor:
- Perform a functional ESC system check.

ELECTRONIC SPARK CONTROL SYSTEM

UNIT 10

ANSWERS TO TEST

1. What is the purpose of the electronic spark control system?

To reduce HC, CO and NO_x emissions by operating with a retarded spark when outside air temperature is below 15°C(60°F) and vehicle speed is below a specified road speed.

2. Write the purpose of each of the components in the ESC system.

(Main Points)

- a. Solenoid Vacuum Control Valve - To control carburetor vacuum to the vacuum advance unit. This determines whether spark will be retarded or advanced. When the valve solenoid is energized - no vacuum advance can occur.
- b. Temperature Switch - Provides power to the electronic amplifier when ambient air temperature is above 15°C(60°F). Located in door pillar to sense ambient air temperature.
- c. Speed Sensor - A small generator that develops a voltage signal proportional to vehicle speed. This signal is sent to the electronic amplifier and its strength determines when the solenoid on the vacuum control valve is energized or deenergized. The speed sensor is located in the speedometer cable.
- d. Electronic Amplifier - Energized from the temperature switch when ambient air temperature is above 15°C(60°F). Between 0 and some preset speed the electronic amplifier energizes the solenoid on the vacuum control valve and blocks vacuum to the vacuum advance unit. Above a preset speed the vacuum control valve solenoid will be deenergized and normal vacuum advance will be allowed.

3. Identify components of the ESC system.
 - a. Speed sensor
 - b. Temperature switch
 - c. Electronic amplifier
 - d. Solenoid vacuum control valve
4. Discuss in writing ESC system operation.
 - a. When ambient temperature is below 15°C(60°F).
 1. Temperature switch is open
 2. Electronic amplifier is deenergized
 3. Normal vacuum advance allowed
 - b. Above 15°C(60°F).
 1. Temperature switch closed, electronic amplifier energized.
 2. Between 0 and 35 mph speed sensor signal causes electronic amplifier to energize solenoid on vacuum control valve.
 3. This blocks vacuum and results in retarded spark timing.
 4. When speed exceeds approximately 35 mph, the speed sensor signal causes the electronic amplifier to deenergize the solenoid on the vacuum control valve allowing vacuum advance to occur.
 5. At approximately 18 mph during deceleration the solenoid on the vacuum control valve is energized, again blocking off vacuum to the vacuum advance unit.

EXHAUST GAS RECIRCULATION SYSTEM

UNIT 11

TERMINAL OBJECTIVE

After completion of this unit the student will be able to explain the purpose of the exhaust gas recirculation system and explain the purpose of exhaust gas recirculation components. The student will be able to visually inspect, test and service the exhaust gas recirculation system.

This will be evidenced through demonstration and scoring 85% minimum on the unit test.

SPECIFIC OBJECTIVES

After completion of this unit the student will be able to:

1. Write the purpose of the exhaust gas recirculation (EGR) system.
2. Write the purpose of each of the components in the ported vacuum control EGR system.
3. Write the purpose of each of the components in the venturi vacuum control system.
4. Identify the components of both EGR systems.
5. Identify the main parts of the EGR valve.
6. Discuss in writing the EGR system operation.
7. Demonstrate the ability to:
 - a. Test EGR control system operation.
 - b. Test EGR valve for proper operation.

EXHAUST GAS RECIRCULATION SYSTEM

UNIT 11

SUGGESTED ACTIVITIES

- I. Instructor
 - A. Provide students with objective sheet
 - B. Provide students with information and job sheets
 - C. Make transparencies
 - D. Discuss terminal and specific objectives
 - E. Discuss information sheets
 - F. Demonstrate and discuss procedures outlined on job sheets
 - G. Give test
- II. Student
 - A. Read objective sheet
 - B. Study information sheet
 - C. Demonstrate ability to accomplish procedures
 - D. Take test

INSTRUCTIONAL MATERIALS

- I. Included in this unit:
 - A. Objective sheet
 - B. Information sheet
 - C. Transparency masters
 - 11-TM-1 - Ported Vacuum Control EGR System
 - 11-TM-2 - Venturi Vacuum Control EGR
 - 11-TM-3 - Temperature Control Vacuum Valve
 - 11-TM-4 - EGR Valve

d. Job sheets

1. Test IGR Control System Operation
2. Test EGR Valve for Proper Operation

E. Test

F. Answers to test

II. References

1. 1973 Chevrolet Service Manual (contact local dealer).
2. Chrysler Corporation. 1973 Emission Controls, Chrysler Corp.,
P. O. Box 2119, Detroit, Mich. 48231, Attention C. G. Palus.
3. Gargano Promotions. Vehicle Emission Control, 12324 West Seven
Mile Road, Detroit, Mich. 48235, Gargano Promotions (1973).

EXHAUST GAS RECIRCULATION SYSTEM

UNIT - 11

INFORMATION SHEET

- I. PURPOSE OF THE EXHAUST GAS RECIRCULATION SYSTEM - To supply, in proper proportion, inert exhaust gas to the air-fuel mixture in the intake manifold. This dilution of the air-fuel mixture reduces peak flame temperatures during combustion and reduces the amount of oxides of nitrogen (NO_x) in the exhaust.
- II. COMPONENTS OF THE PORTED VACUUM CONTROL EGR SYSTEM - TM-1
 - A. EGR Valve - Meters or shuts off exhaust gas flow to the air-fuel side of the intake manifold.
 - B. Intake Manifold - Contains specially cast exhaust passages that connect to the intake side of the manifold through the EGR valve.
 - C. Carburetor Signal Port - Located in the carburetor throttle body where it is exposed to an increasing manifold vacuum signal as the throttle blade opens. This signal controls the EGR valve.
- III. COMPONENTS IN THE VENTURI VACUUM CONTROL EGR SYSTEM - TM-2
 - A. EGR Valve - Meters or shuts off exhaust gas flow to the air-fuel side of the intake manifold.
 - B. Intake Manifold - Contains specially cast exhaust passages that connect to the intake side of the manifold through the EGR valve.
 - C. Venturi Vacuum Signal Tap - Provides a low amplitude vacuum signal from the throat of the carburetor venturi to the amplifier unit.
 - D. Amplifier - Uses weaker venturi vacuum signal to control the stronger manifold vacuum that is needed to control the EGR valve.
 - E. Temperature Controlled Vacuum Valve - TM-3 - Prevents vacuum from reaching and actuating the EGR valve until radiator coolant temperature reaches approximately 16°C (60°F).

NOTE: Also found on some ported vacuum control EGR systems.

10. The manifold vacuum is _____.

A. always the same for all

engines

B. a function of throttle

position

C. valve-in-the-head

D. valve

E. valve-in-head

11. At idle, the _____

A. when engine is started and radiator fan starts to permit the engine to warm up immediately (in 100°F), the temperature controller valve will convert to vacuum, thus opening the lift valve to increase air flow availability.

B. when radiator fan tank temperature is only approximately 100°F , the vacuum circuit opens the lift valve.

C. As engine speed is increased and approximately 1000 RPM is reached, the lift valve is closed and the air flow is held at the increased manifold port, the lift valve is closed.

D. It is allow constant air to flow with and dilute the air-fuel mixture.

E. The dilution lowers the post flame temperature of engine and reduces NO_x emissions.

F. As acceleration is increased, the manifold vacuum falls and the air flow signal port increases and as between 1000 and 1500 RPM maximum flow occurs through the lift valve.

G. At wide open throttle, the manifold vacuum drops to zero with the vacuum to the lift valve and to the air flow signal port is closed.

H. At idle, the throttle plate position is below the manifold vacuum port and no exhaust gas recirculation takes place.

PORTED VACUUM CONTROL EGR SYSTEM

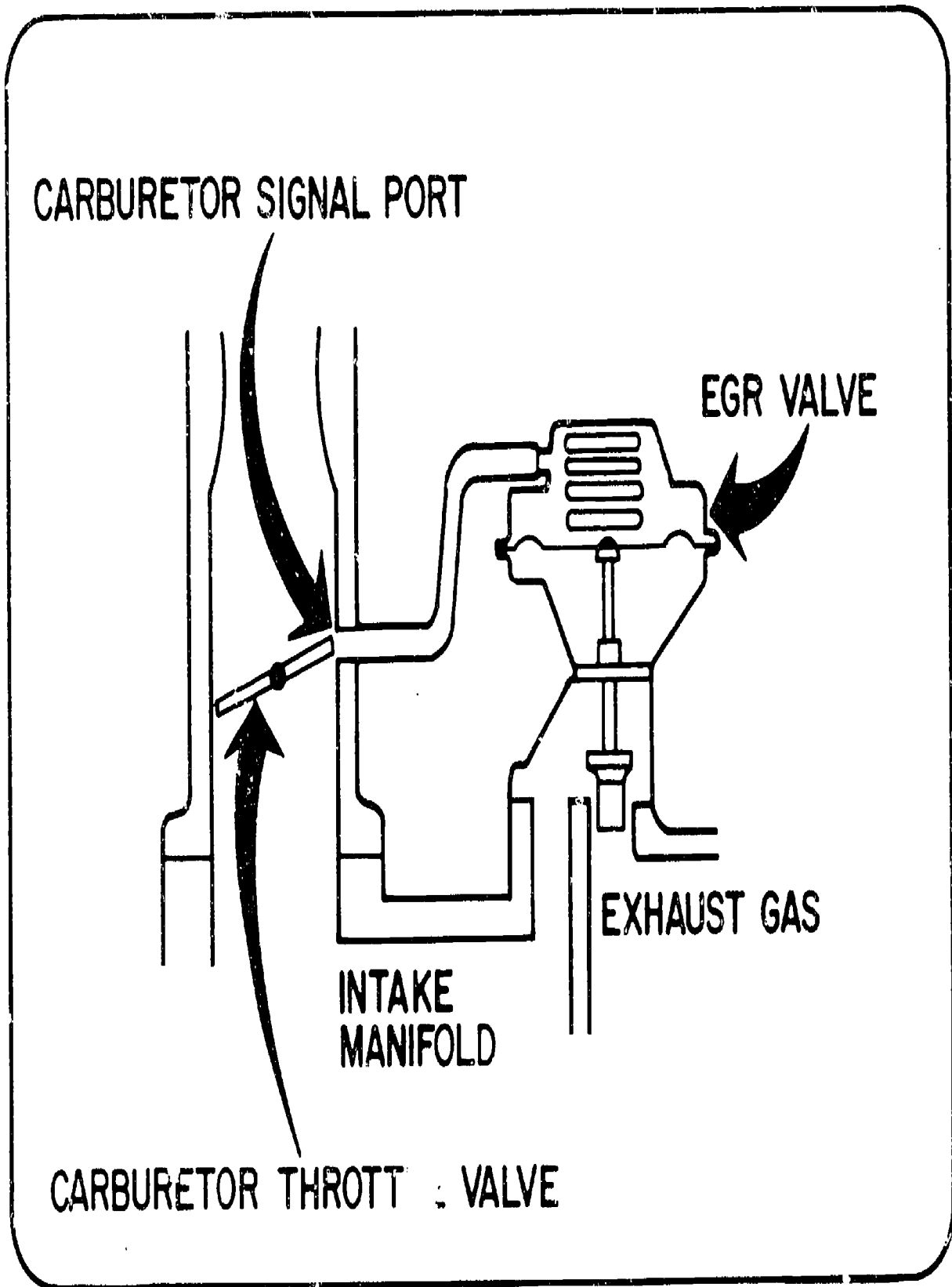

VENTURI VACUUM CONTROL EGR

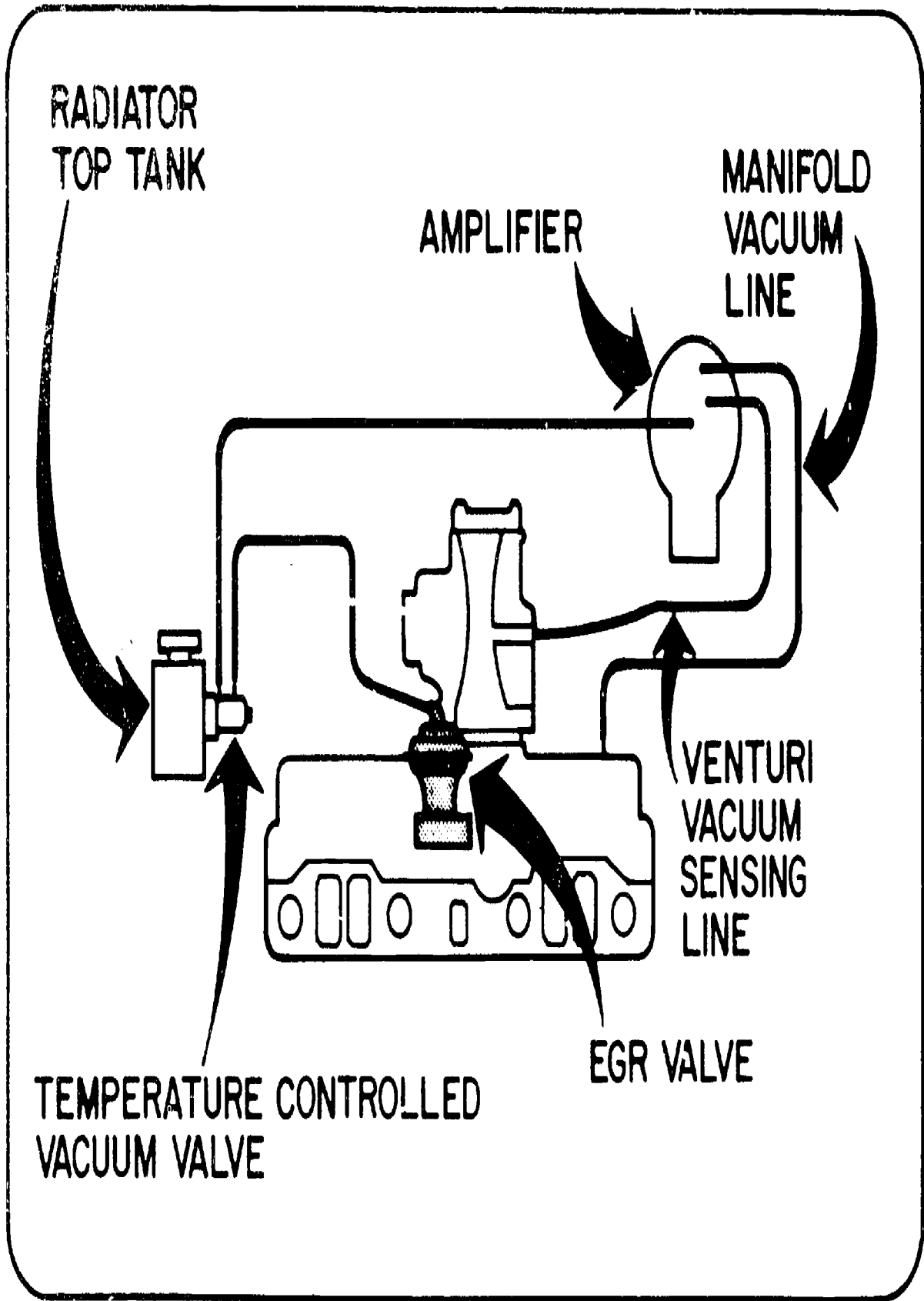

TM-2

TEMPERATURE CONTROL VACUUM VALVE

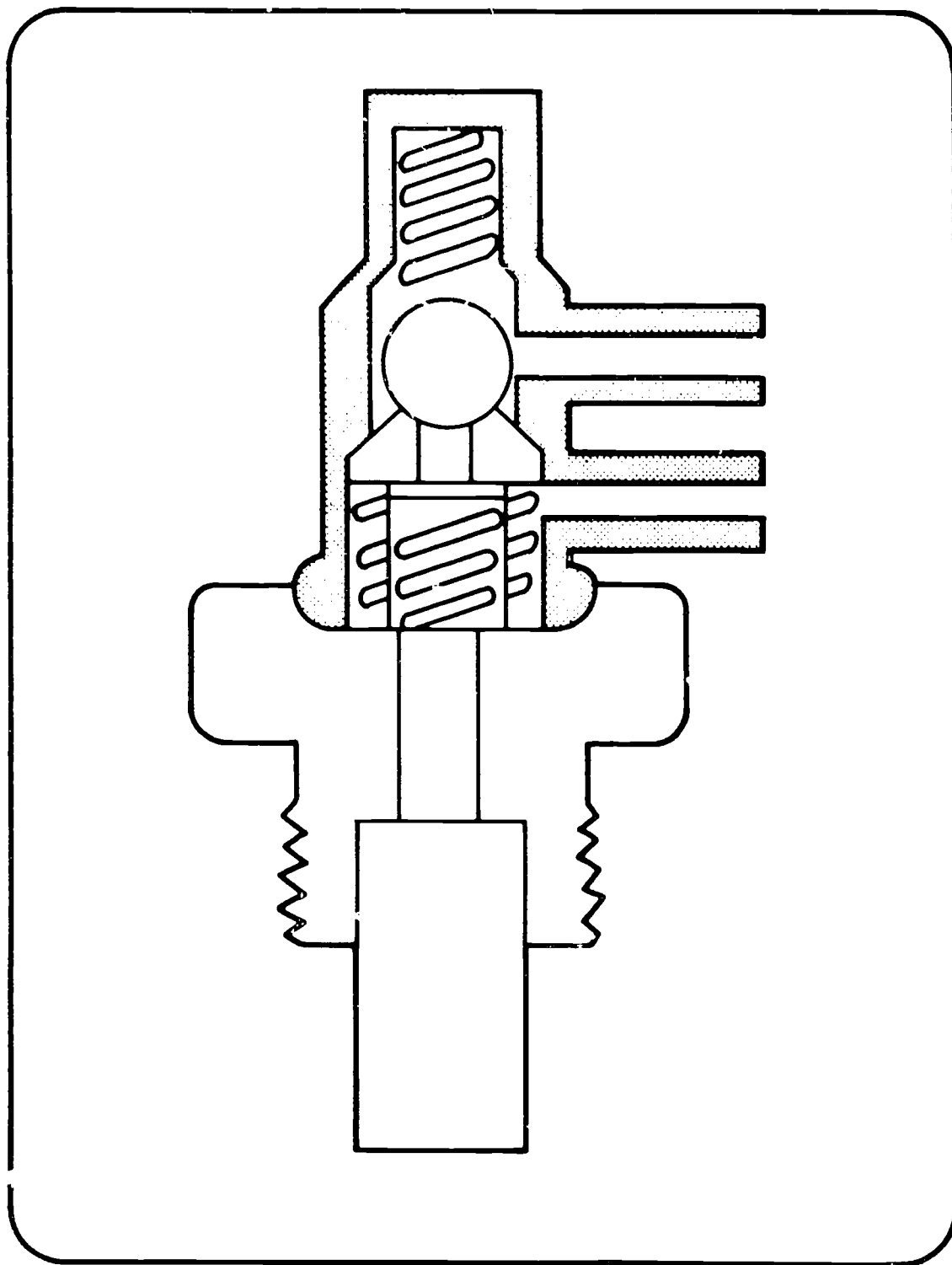

199

EGR VALVE

EGR VALVE (CLOSED)

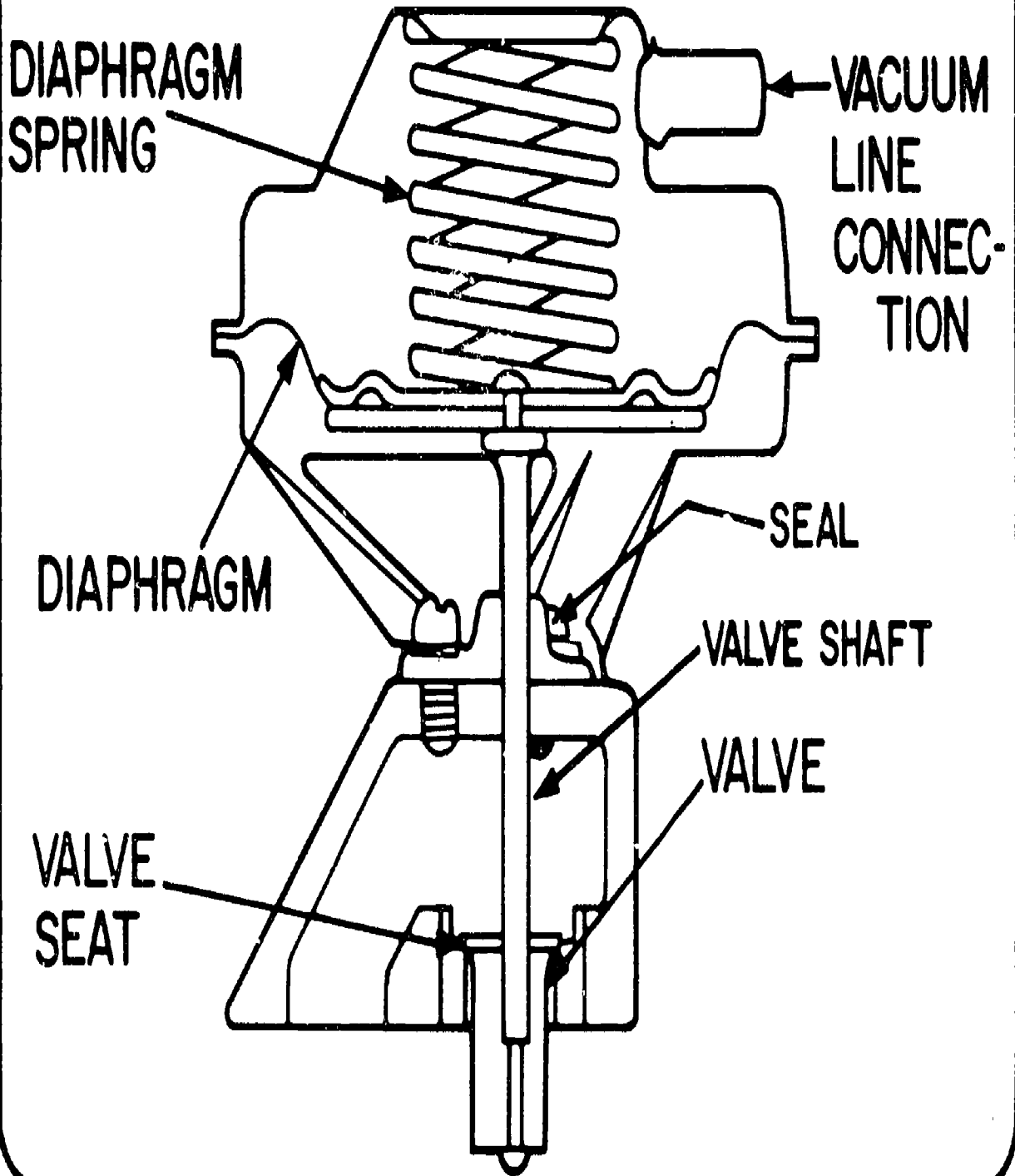

EXHAUST GAS RECIRCULATION SYSTEM

UNIT 11

JOB SHEET #1 - TEST EGR CONTROL SYSTEM OPERATION

I. Tools required

Tachometer

II. Procedure

- A. Inspect all hose connections for looseness.
- B. Check for hardened or cracked vacuum hoses.
- C. Hook up tachometer.
- D. Start engine and allow it to come to normal operating temperature with transmission in neutral.
- E. Accelerate the engine to approximately 2000 rpm rapidly (do not exceed 3000 rpm).
- F. During E, observe EGR valve stem for visible movement.
- G. If valve stem moves, the control system is functioning properly.

NOTE: These are BASIC PROCEDURES. Check the manufacturers service shop manual or technical manual for exact procedures for each make and model.

JOB SHEET #2 - TEST EGR VALVE FOR PROPER OPERATION

I. Tools required

- A. Vacuum gauge
- B. Tee connection

II. Procedure

- A. Install vacuum gauge at EGR valve.
- B. With transmission in neutral, start engine and allow it to come to operating temperature.
- C. Accelerate engine quickly and observe vacuum gauge. Vacuum should increase as engine speed increases.
- D. At 3 - 4 inches of vacuum, the EGR valve should start to open.
- E. At 5 - 10 inches vacuum, the valve should be wide open.
- F. Disconnect vacuum gauge from EGR valve.
- G. With engine idling, connect manifold vacuum source to the EGR valve.
- H. The engine should lose rpm, idle very rough and possibly stall. This step shows that the EGR passages are clear and not plugged.

NOTE: These are BASIC PROCEDURES. Check the manufacturers service shop manual or technical manual for exact procedures for each make and model.

EXHAUST GAS RECIRCULATION SYSTEM

UNIT 11

TEST

1. What is the purpose of CO_2 system?

2. Write the purpose of each component in the ported vacuum control EC system.
 - a.

 - b.

 - c.

4.3. Write the purpose of each of the components of the venturi vacuum control system.

a.

b.

c.

d.

e.

4. Identify the components of the ported vacuum control EGR system.

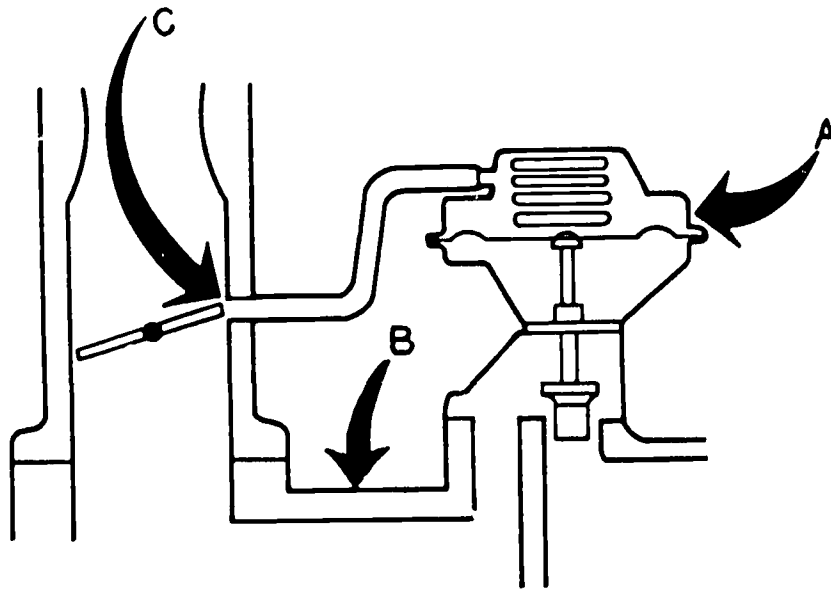

a.

b.

c.

4. (Continued)

Identify the components in the venturi vacuum control EGR system.

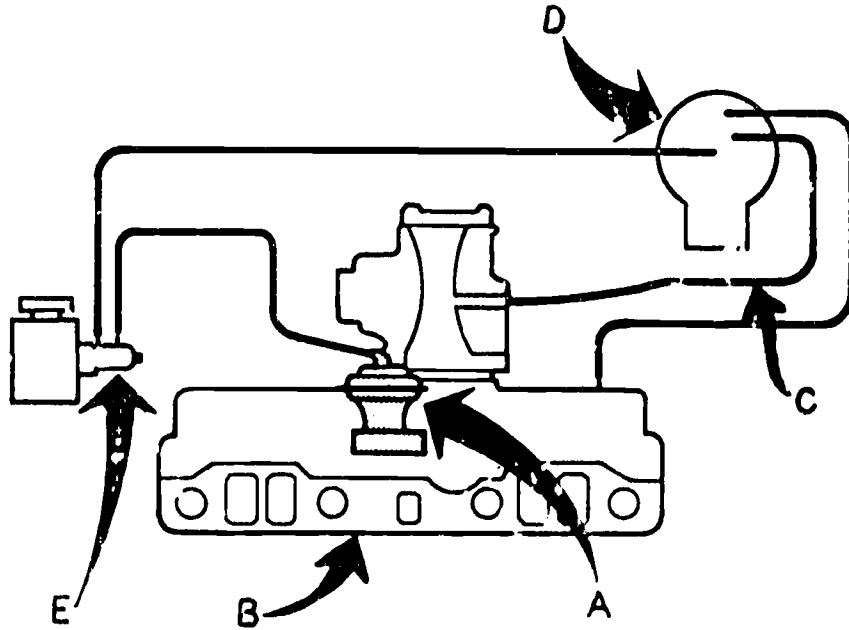

a.

b.

c.

d.

e.

5. Identify the main parts of the EGR valve.

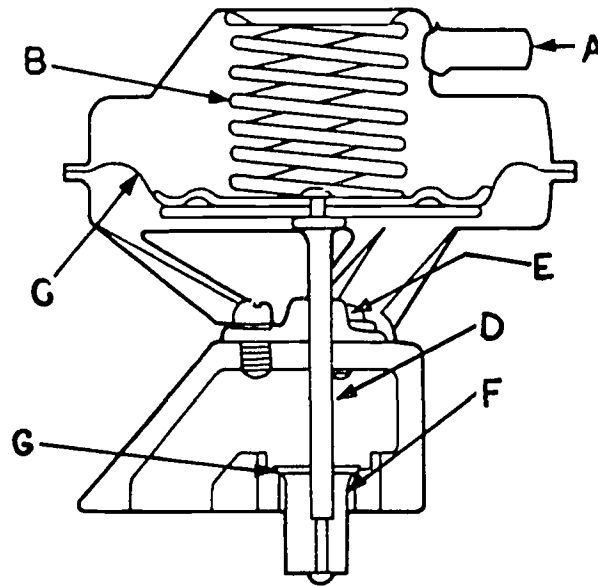

a.

b.

c.

d.

e.

f.

g.

6. Discuss in writing the EGR system operation.

7. The student should demonstrate the ability to perform the following jobs to the satisfaction of the instructor:

- a. Test EGR control system operation.
- b. Test EGR valve for proper operation.

EXHAUST GAS RECIRCULATION SYSTEM

UNIT 11

ANSWERS TO TEST

1. What is the purpose of the EGR system?

To supply in proper proportion inert exhaust gas to the air-fuel mixture in the intake manifold. Dilution of air-fuel mixture lowers peak flame temperatures during combustion and reduces the amount of oxides of nitrogen (NO_x) in the exhaust.

2. Write the purpose of each component in the ported vacuum control EGR system.

- a. EGR Valve - Meters or shuts off exhaust gas flow to the air-fuel side of the intake manifold.
- b. Intake Manifold - Has specially cast passages.
- c. Carburetor Signal Port - Located in the carburetor throttle body where it is exposed to an increasing manifold vacuum signal as the throttle blade opens. This signal controls the EGR valve.

3. Write the purpose of each of the components of the venturi vacuum control EGR system.

- a. EGR Valve - Meters or shuts off exhaust gas flow to the air-fuel side of the intake manifold.
- b. Intake Manifold - Contains specially cast exhaust passages that connect to the intake side of the manifold through the EGR valve.
- c. Venturi Vacuum Signal Tap - Provides a low amplitude vacuum signal from the throat of the carburetor venturi to the amplifier unit.
- d. Amplifier - Uses weaker venturi vacuum signal to control the stronger manifold vacuum that is needed to control the EGR valve.

- e. Temperature Controlled Vacuum Valve - Prevents vacuum from reaching and operating the IGR valve until radiator top tank temperature reaches a maximum of 160°(60°F).
- With: Also found on some ported vacuum control EGR systems.
- 4(a). Identify the components of the ported vacuum control system.
- IGR valve
 - Intake manifold
 - Carbonator signal port
- 4(b). Identify the components of the venturi vacuum control system.
- IGR valve
 - Intake manifold
 - Venturi vacuum drawing line
 - Split line
 - Temperature controlled vacuum valve
5. Identify the main parts of the IGR valve.
- Vacuum line connection
 - Spring
 - Actuator, diaphragm
 - Valve shaft
 - Valve shaft seal
 - Valve
 - Valve seat
6. Discuss in writing the EGR system operation.
- When the engine is started and the radiator top tank temperature is below a maximum of 160°(60°F), the temperature controlled valve will prevent vacuum from reaching the IGR valve to operate the device.

- b. When radiator top tank temperature exceeds approximately 16°C(60°F), vacuum can reach the EGR valve.
- c. As engine speed is increased and approximately 3 - 5 inches of vacuum is felt at the carburetor signal port, the EGR valve begins to open.
 - ! This allows exhaust gas to mix with and dilute the incoming air-fuel mixture.
- e. The dilution lowers the peak flame temperature of combustion and reduces NO_x emissions.
- f. As acceleration is increased, the manifold vacuum felt at carburetor signal port increases and at between 5 - 8 inches of vacuum, the maximum flow occurs through the EGR valve.
- g. At wide open throttle the manifold vacuum drops below the minimum vacuum to open the EGR valve and no exhaust gas recirculation takes place.
- h. At idle, the throttle blade position is below the carburetor signal port and no exhaust gas recirculation takes place.

POSITIVE CRANKCASE VENTILATION SYSTEMS

UNIT 12

TERMINAL OBJECTIVE

After completion of this unit the student will be able to explain the purpose of the positive crankcase ventilation (PCV) system and explain the purpose of the open and closed PCV system components. The student will be able to visually inspect, test and service a PCV system.

This will be evidenced through demonstration and scoring 85% minimum on the unit test.

SPECIFIC OBJECTIVES

After completion of this unit the student will be able to:

1. Write the purpose of the positive crankcase ventilation (PCV) system.
2. Write the purpose of each component of the open PCV system.
3. Write the purpose of each component of the closed PCV system.
4. Identify the parts of both PCV systems.
5. Identify the parts of the PCV valve.
6. Explain how the PCV valve is controlled and identify valve position during various modes of engine operation.
7. Demonstrate the ability to:
 - a. Perform general test of PCV system.
 - b. Test PCV system operation with tachometer.

POSITIVE CRANKCASE VENTILATION SYSTEMS

UNIT 12

SUGGESTED ACTIVITIES

I. Instructor

- A. Provide students with objective sheet
- B. Provide students with information and job sheets
- C. Make transparencies
- D. Discuss terminal and specific objectives
- E. Discuss information sheets
- F. Demonstrate and discuss procedures outlined on job sheets
- G. Give test

II. Student

- A. Read objective sheet
- B. Study information sheet
- C. Demonstrate ability to accomplish the procedures
- D. Take test

INSTRUCTIONAL MATERIALS

I. Included in this unit:

- A. Objective sheet
- B. Information sheet
- C. Transparency masters
 - 12-TM-1 - Open PCV System
 - 12-TM-2 - Closed PCV System
 - 12-TM-3 - PCV Valve Components
 - 12-TM-4 - PCV Valve Positions

- D. Job sheets
 - 1. General Test of PCV System
 - 2. Testing PCV Operation
 - E. Test
 - F. Answers to test
- II. References
1. Chrysler Corporation. 1973 Emission Controls, Chrysler Corp., P. O. Box 2119, Detroit, Mich. 48231, Attention C. G. Palus.
 2. Gargano Promotions. Vehicle Emission Control, 12824 West Seven Mile Road, Detroit, Mich. 48235, Gargano Promotions (1973).
 3. Glenn, Harold T. Glenn's Emission Control Systems, Chicago, Ill., Henry Regnery Co., (1972).
 4. Patterson, D. J. and Henein, N. A. Emissions from Combustion Engines and Their Control, Ann Arbor Science Publishers, Inc., Ann Arbor, Mich. (1973).
 5. Motor's Emission Control Manual, by Joe Oldham and Lou Forier, Motor, New York, N. Y.

POSITIVE CRANKCASE VENTILATION SYSTEMS

UNIT 12

INFORMATION SHEET

- I. PURPOSE OF THE PCV SYSTEM - To reduce hydrocarbon emissions to the atmosphere as well as oil dilution and sludge formation in the crankcase. This is done by directing blowby gases in the crankcase back to the combustion chamber to be consumed in the normal combustion process.
- II. COMPONENTS OF THE OPEN PCV SYSTEM - TM-1
 - A. Vented Oil Filler Cap - Allows outside air to be drawn into the crankcase.
 - B. PCV Valve - Meters the flow of blowby gases in the crankcase back to the intake manifold.
- III. COMPONENTS OF THE CLOSED PCV SYSTEM - TM-2
 - A. Non-Vented (sealed) Oil Filler Cap - Prevents escape of blowby gases back to atmosphere during heavy acceleration.
 - B. Sealed Dipstick Cap - Prevents escape of blowby gases back to atmosphere during heavy acceleration.
 - C. Air Intake Hose - Allows fresh air to enter crankcase from the air cleaner (can be from either the clean side or dirty side of air cleaner) and during heavy acceleration forces any blowby gases that may back up to be mixed with the air entering the carburetor.
 - D. PCV Valve - Meters the flow of blowby gases in the crankcase back to the intake manifold.
- IV. COMPONENTS OF PCV VALVE - TM-3
 - A. Body
 - B. Plunger
 - C. Spring

V. PCV VALVE CONTROL AND OPERATION - TM-4

- A. With the engine shut off or during engine backfire the PCV is in the closed position.
- B. During low speed or idle conditions (high manifold vacuum) the plunger is pulled against spring tension to the extreme forward position.
- C. In this position flow is restricted to the intake manifold but not stopped.
- D. Manifold vacuum decreases as engine speed increases which allows the spring to force the plunger to a mid position where maximum flow can occur.

OPEN PCV SYSTEM

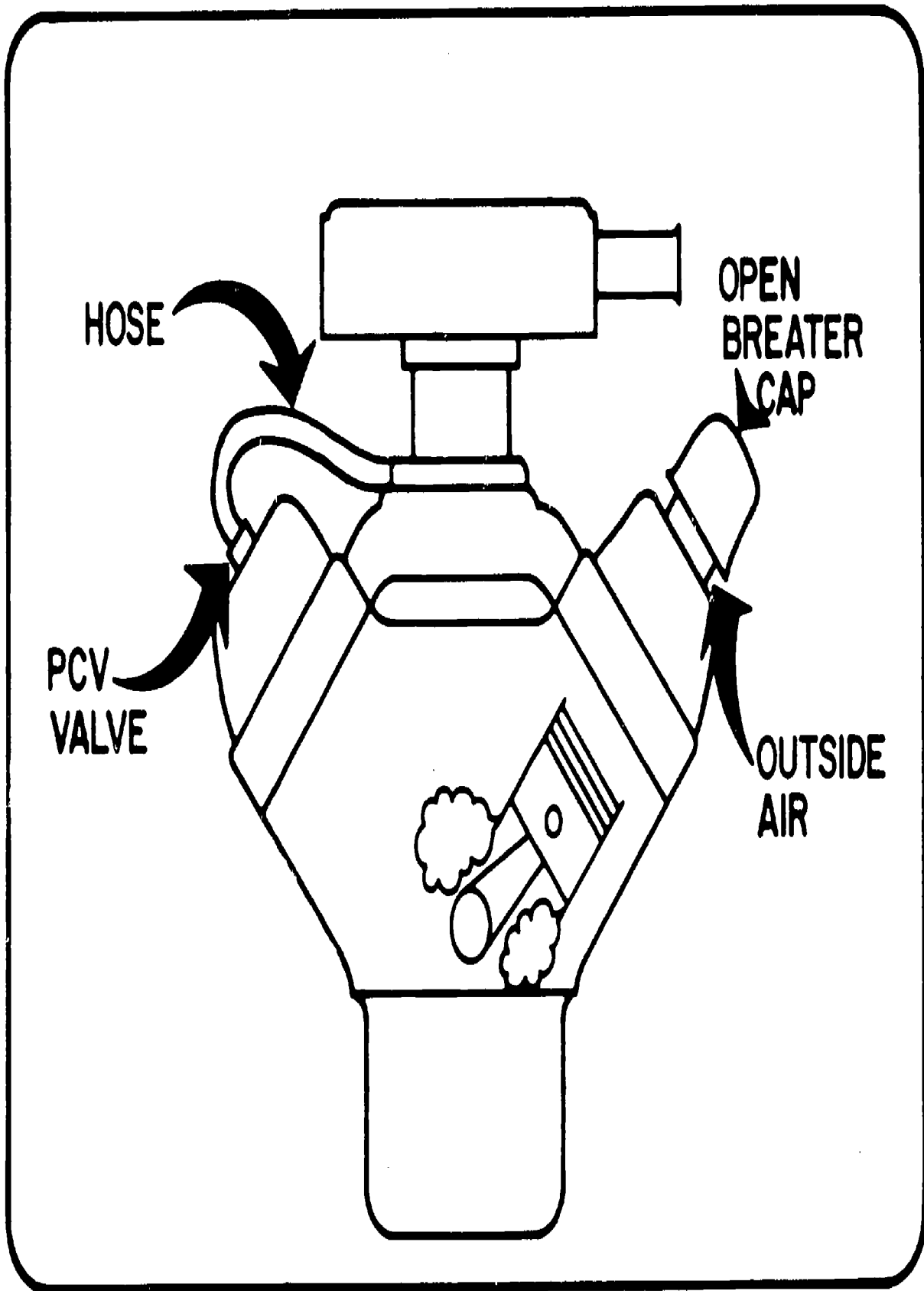

CLOSED PCV SYSTEM

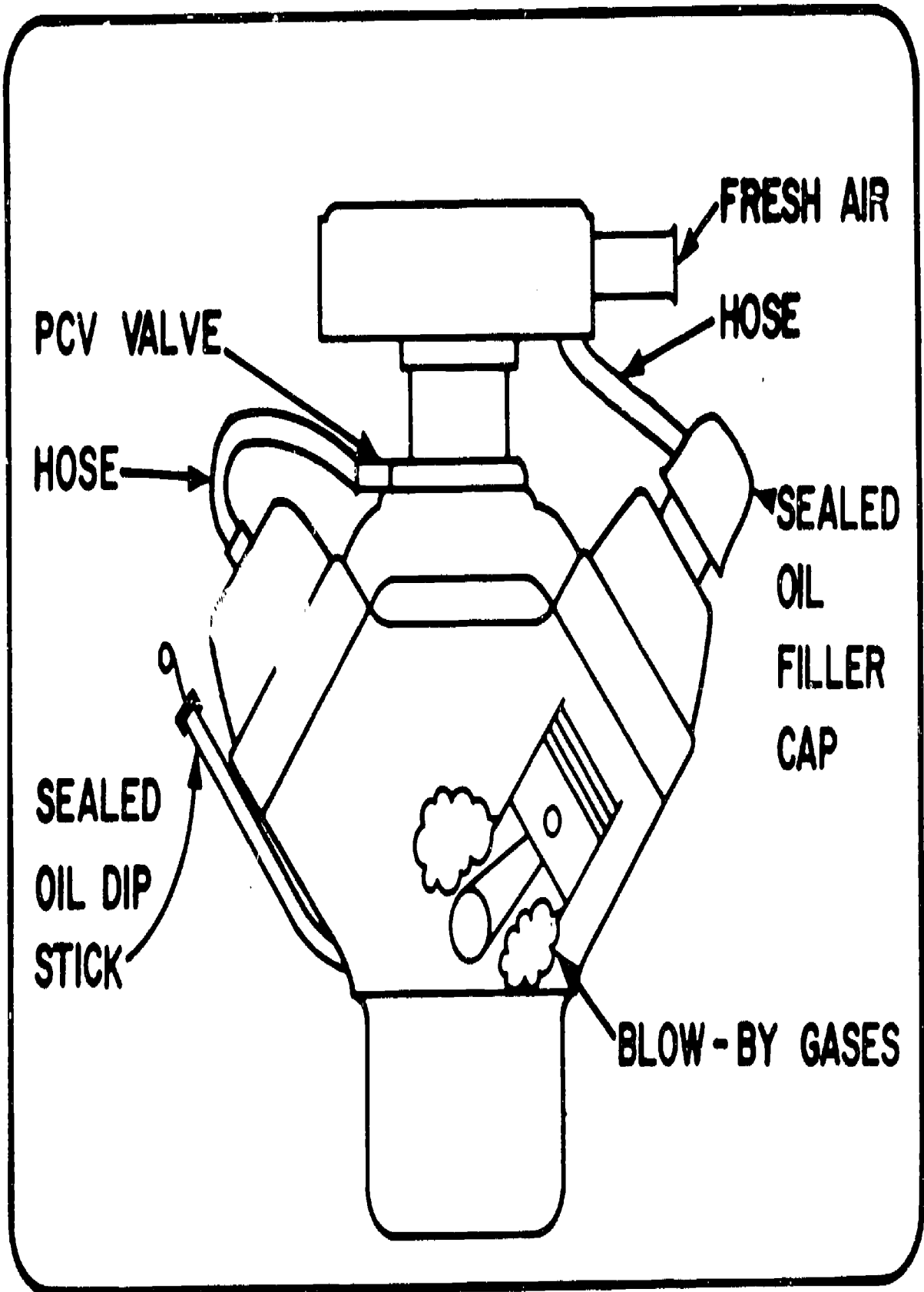

PCV VALVE COMPONENTS

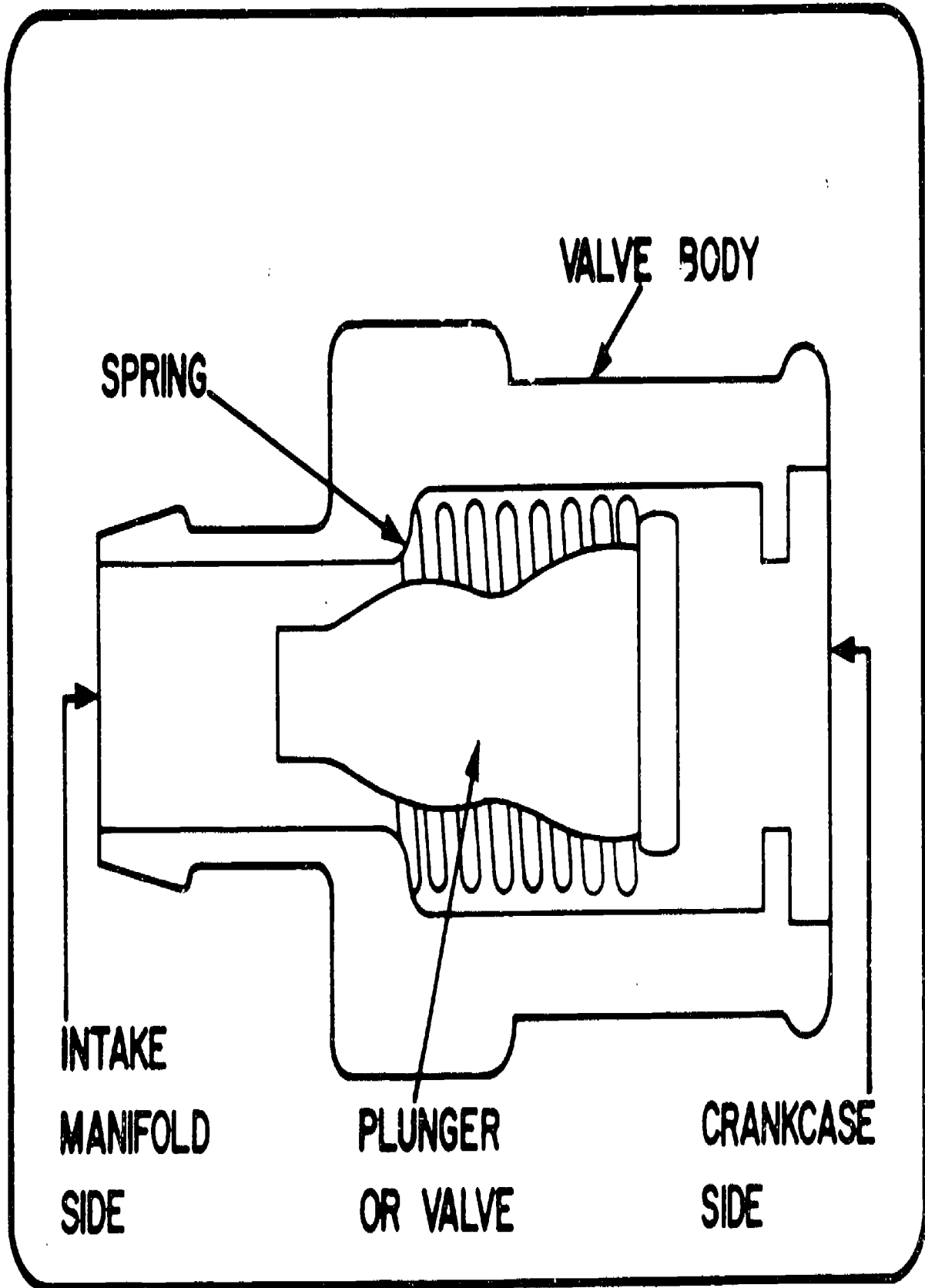

PCV VALVE POSITIONS

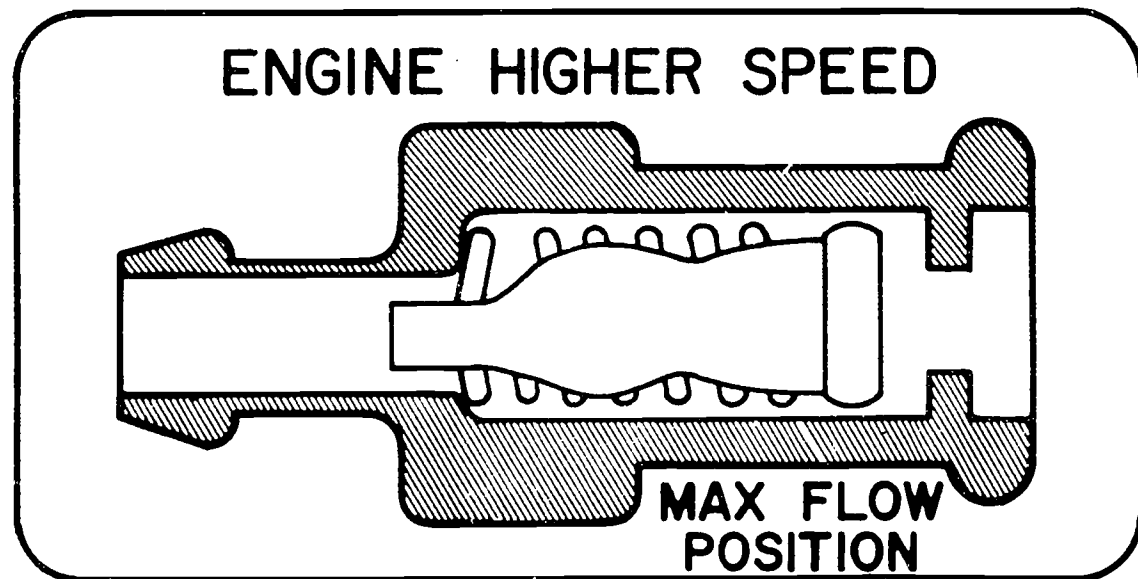
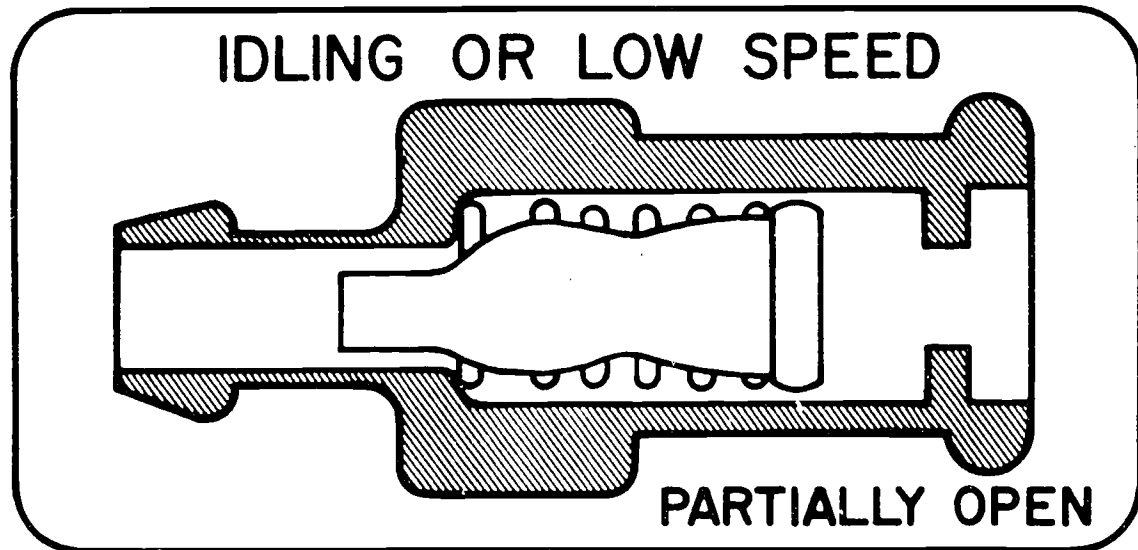
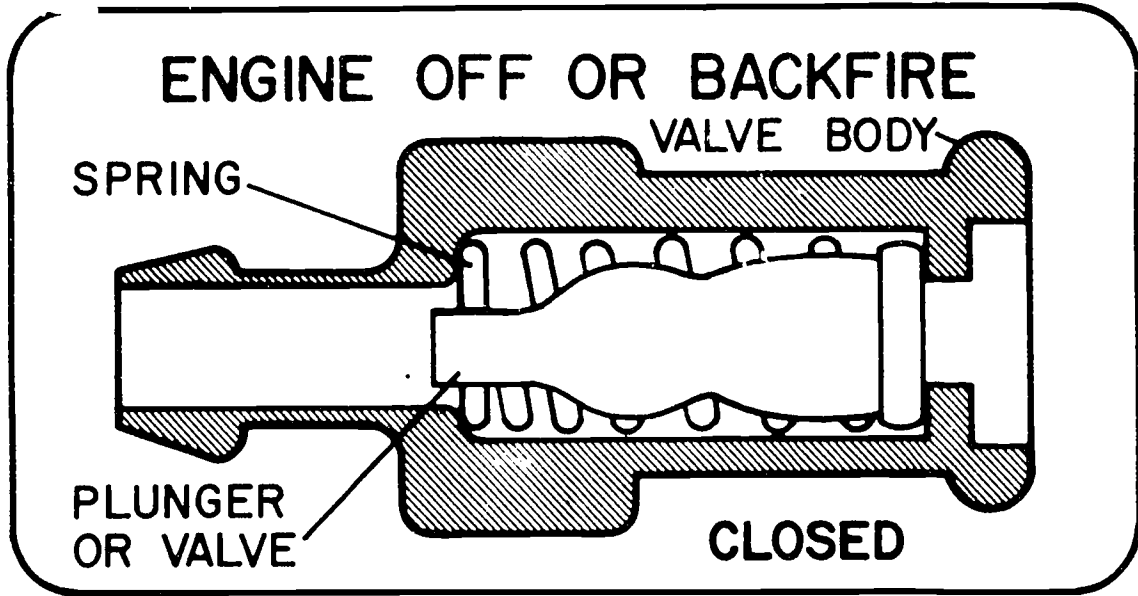

POSITIVE CRANKCASE VENTILATION SYSTEMS

UNIT 12

JOB SHEET #1 - GENERAL TEST OF PCV SYSTEM

I. Tools required

Hand tools as needed

II. Procedure

- A. Remove PCV valve.
- B. Shake PCV valve - clicking noise should be heard.
- C. Reinstall valve in hose leading to intake manifold. Leave other end of PCV valve disconnected.
- D. Start the engine - A distinct hissing noise should be heard.
- E. Place finger over the end of the PCV valve, a strong vacuum should be felt.
- F. Reinstall PCV valve.
- G. Remove oil filler cap.
- H. Hold a piece of fairly heavy paper next to the opening (it should be drawn down against the opening with noticeable force).
- I. Reinstall oil filler cap.
- J. Shut off engine.

The preceding results show that the PCV valve is operating and the system hoses are clear.

NOTE: These are BASIC PROCEDURES. Check the manufacturers service shop manual or technical manual for exact procedures for each make and model.

JOB SHEET #2 - TESTING PCV SYSTEM OPERATION WITH TACHOMETER

I. Tools required

Tachometer

II. Procedure

- A. Connect tachometer to the engine.
- B. Start the engine.
- C. Clamp off the hose between the PCV valve and the intake manifold.
- D. If the system is operating correctly, a drop of 40-80 rpm will be seen on the tachometer.
- E. No change in rpm indicates a sticking PCV valve or plugged hoses.
- F. A drop in engine rpm in excess of 80 rpm, indicates that the wrong PCV valve for that engine has been installed.

NOTE: These are BASIC PROCEDURES. Check the manufacturers service shop manual or technical manual for exact procedures for each make and model.

POSITIVE CRANKCASE VENTILATION SYSTEMS

UNIT 12

T E S T

1. What is the purpose of the positive crankcase ventilation (PCV) system?

2. Write the purpose of each component of the open PCV system.

a.

b.

3. Write the purpose of each component of the closed PCV system.

a.

b.

c.

d.

4. Identify the parts of both PCV systems.

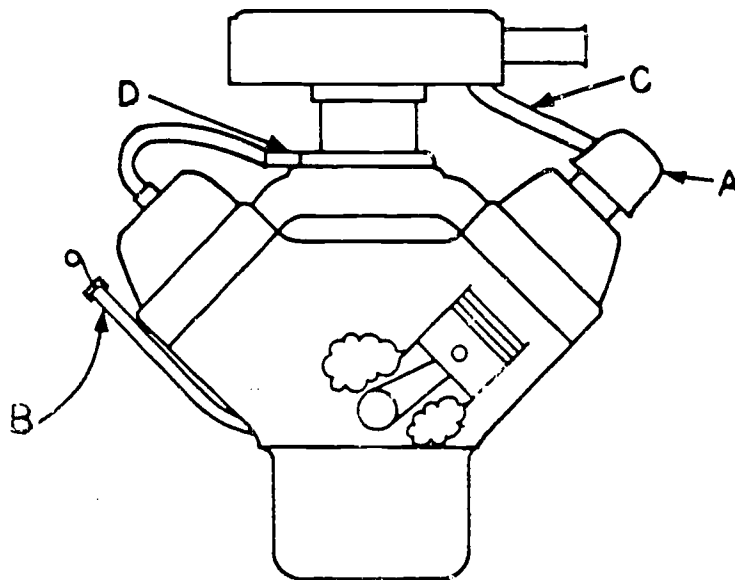
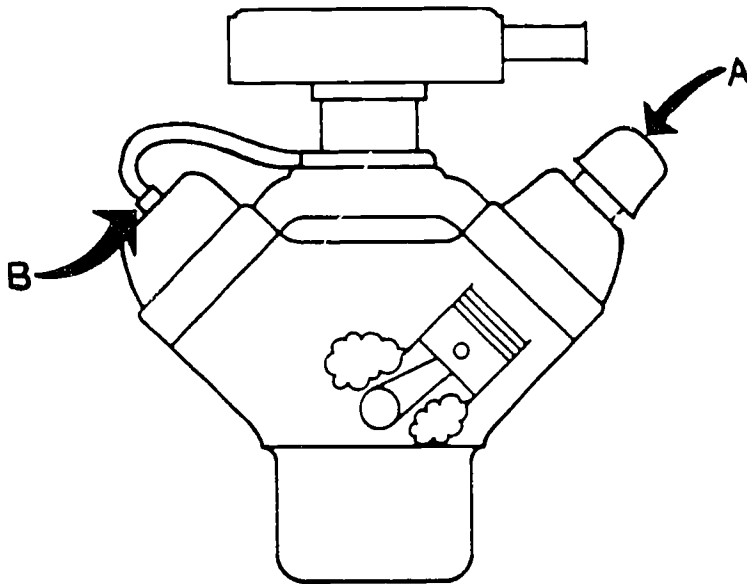

- a.
- b.
- c.
- d.

5. Identify the parts of the PCV valve.

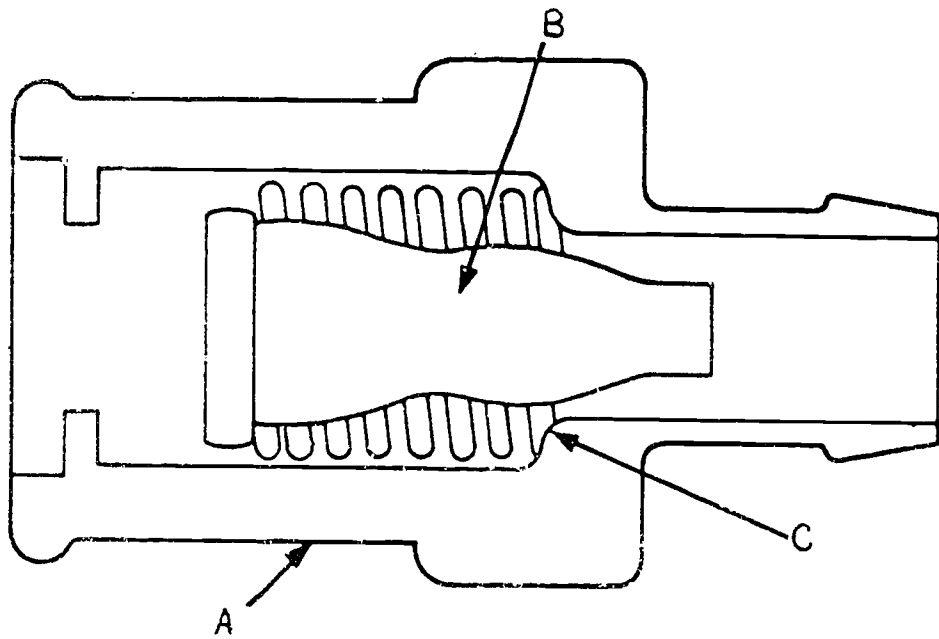

a.

b.

c.

6. Explain how the PCV valve is controlled and identify valve position during various modes of engine operation.

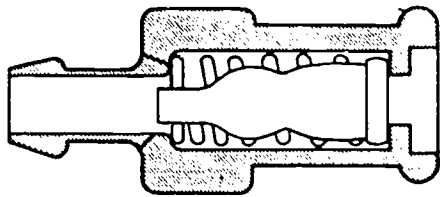

Engine operating mode _____

Valve position _____

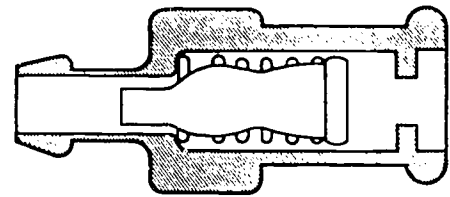

Engine operating mode _____

Valve position _____

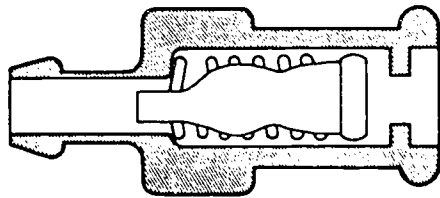

Engine operating mode _____

Valve position _____

7. The student should demonstrate the ability to perform the following to the satisfaction of the instructor:
 - a. General test of the PCV system.
 - b. Testing PCV operation.

POSITIVE CRANKCASE VENTILATION SYSTEMS

UNIT 12

ANSWERS TO TEST

1. What is the purpose of the positive crankcase ventilation (PCV) system?
Reduce hydrocarbon emissions to atmosphere as well as oil dilution and sludge formation in the crankcase. This is done by directing blowby gases in the crankcase back to the combustion chamber to be consumed in the normal combustion process.
2. Write the purpose of each component of the open PCV system.
 - a. Vented Oil Filler Cap - Allows outside air to be drawn into the crankcase.
 - b. PCV Valve - Meters flow of blowby gases back to intake manifold.
3. Write the purpose of each component of the closed PCV system.
 - a. Non-Vented Oil Filler Cap - Prevents escape of blowby gases back to atmosphere during hard acceleration.
 - b. Sealed Dipstick Cap - Same as a.
 - c. Air Intake Hose - Allows fresh air to enter crankcase from the dirty or clean side of air cleaner and during hard acceleration forces any blowby gases that may back up to be mixed with the air entering the carburetor.
 - d. PCV Valve - Meters the flow of blowby gases in the crankcase back to the intake manifold.
4. Identify the parts of both systems.
 - a. Vented oil filler cap
 - b. PCV valve

4. (Continued)
 - a. Non-vented oil filler cap
 - b. Sealed dipstick cap
 - c. Air intake hose
 - d. PCV valve
5. Identify the parts of the PCV valve.
 - a. Body
 - b. Plunger
 - c. Spring
- 6(a). Explain how the PCV valve is controlled.
 - a. With the engine shut off or during engine backfire the PCV is in the closed position.
 - b. During low speed or idle conditions (high manifold vacuum), the plunger is pulled against spring tension to the extreme forward position.
 - c. In this position flow is restricted to the intake manifold but not stopped.
 - d. Manifold vacuum decreases as engine speed increases which allows the spring to force the plunger to a mid position where maximum flow can occur.
- 6(b). Identify valve position with mode of engine operation.
 1. Closed
 1. Off or during backfire
 2. Partially opened
 2. Lower idle speeds
 1. Max flow
 2. Higher engine speeds

AIR INJECTION SYSTEM

UNIT 13

TERMINAL OBJECTIVE

After completion of this unit the student will be able to explain the purpose of the air injection system and explain the purpose of air injection system components. The student will be able to visually inspect, test and service the air injection system.

This will be evidenced through demonstration and scoring 85% minimum on the unit test.

SPECIFIC OBJECTIVES

After completion of this unit the student will be able to:

1. Write the purpose of the air injection system
2. Write the purpose of each of the components of the air injection system.
3. Identify the components of the air injection system.
4. Identify five main parts of the air pump.
5. Identify the components of the diverter valve.
6. Discuss in writing how the diverter valve prevents backfire in the exhaust system.
7. Demonstrate the ability to:
 - a. Inspect air manifold and hoses.
 - b. Inspect drive belt and set correct tension.
 - c. Check air pump output.
 - d. Check diverter valve operation.
 - e. Inspect check valve operation.

AIR INJECTION SYSTEM

UNIT 13

SUGGESTED ACTIVITIES

- I. Instructor
 - A. Provide students with objective sheet
 - B. Provide students with information and job sheets
 - C. Make transparencies
 - D. Discuss terminal and specific objectives
 - E. Discuss information sheets
 - F. Demonstrate and discuss procedure outlined on job sheets
 - G. Give test
- II. Student
 - A. Read objective sheet
 - B. Study information sheet
 - C. Demonstrate ability to accomplish the procedures
 - D. Take test

INSTRUCTIONAL MATERIALS

- I. Included in this unit:
 - A. Objective sheet
 - B. Information sheet
 - C. Transparency masters
 - 13-TM-1 - Air Injection System
 - 13-TM-1A - Air Injection Tube In Exhaust Port
 - 13-TM-2 - Air Pump Components
 - 13-TM-3 - External Muffler Type Diverter
 - 13-TM-4 - Check Valve Assembly

D. Job sheets

1. Inspect Air Manifold and Hoses
2. Drive Belt Inspection and Setting
3. Testing the Air Pump
4. Checking Diverter Valve Operation
5. Checking Check Valve Operation

E. Test

F. Answers to test

II. References

1. Chrysler Corporation. 1973 Emission Controls, Chrysler Corp., P. O. Box 2119, Detroit, Mich. 48231, Attention C. G. Palus.
2. Gargano Promotions. Vehicle Emission Control, 12824 West Seven Mile Road, Detroit, Mich. 48235, Gargano Promotions (1973).
3. Glenn, Harold T. Glenn's Emission Control Systems, Chicago, Ill., Henry Regnery Co., (1972).
4. Patterson, D. J. and Henein, N. A. Emissions from Combustion Engines and Their Control, Ann Arbor Science Publishers, Inc., Ann Arbor, Mich. (1973).
5. Motor's Emission Control Manual, by Joe Oldham and Lou Forier, Motor, New York, N. Y.

AIR INJECTION SYSTEMS

UNIT 13

INFORMATION SHEET

- I. PURPOSE OF THE AIR INJECTION SYSTEM - To supply additional oxygen at the exhaust ports in the vicinity of the exhaust valves and thereby extend the combustion process into the exhaust system which leads to a reduction in unburned hydrocarbon and carbon monoxide emissions.
- II. COMPONENTS OF THE AIR INJECTION SYSTEM - TM-1
 - A. Air Pump - Supplies filtered low-pressure air to the system.
 - B. Diverter Valve - Diverts air pump output to atmosphere during deceleration to prevent backfire and has a built-in pressure relief valve to protect the system.
 - C. Check Valve - Prevents hot exhaust gases from backing up into the hoses and pump.
 - D. Air Manifold - Distributes air to each cylinder.
 - E. Air Nozzles - Injects air to each exhaust passage in the near proximity of the exhaust valves - TM-1A
 - F. Manifold Vacuum Signal Line - Senses manifold vacuum to actuate the diverter valve.
- III. COMPONENTS OF AIR PUMP - TM-2
 - A. Housing
 - B. Centrifugal filter
 - C. Vanes (2)
 - D. Rotor
 - E. Seals (2 per vane)

IV. COMPONENTS OF DIVERTER VALVE - TM-3

- A. Air outlets
- B. Air inlet
- C. Pressure relief valve
- D. Manifold vacuum signal line connection
- E. Diaphragm assembly
- F. Diverted air outlet
- G. Metering valve

V. CHECK VALVE - TM-4

- A. Check valve
- B. Check valve body
- C. Check valve spring

VI. OPERATION OF THE DIVERTER VALVE - TM-3

- A. During normal operation the pump discharge enters the diverter valve, passes by the metering valve and is discharged to the air manifold.
- B. During deceleration, the carburetor throttle valves are nearly closed causing a rich air-fuel mixture and high manifold vacuum in the intake manifold.
- C. This rich mixture will not undergo complete combustion and will allow an excessively rich mixture in the exhaust system.
- D. The air supplied by the air pump will provide enough oxygen to ignite this rich mixture and cause a backfire.
- E. The diverter valve senses the high intake manifold vacuum through the signal line connection.
- F. This pulls up the diaphragm assembly which in turn raises the metering valve blocking off the outlet and opening the port to the diverted air outlet.

AIR INJECTION SYSTEM

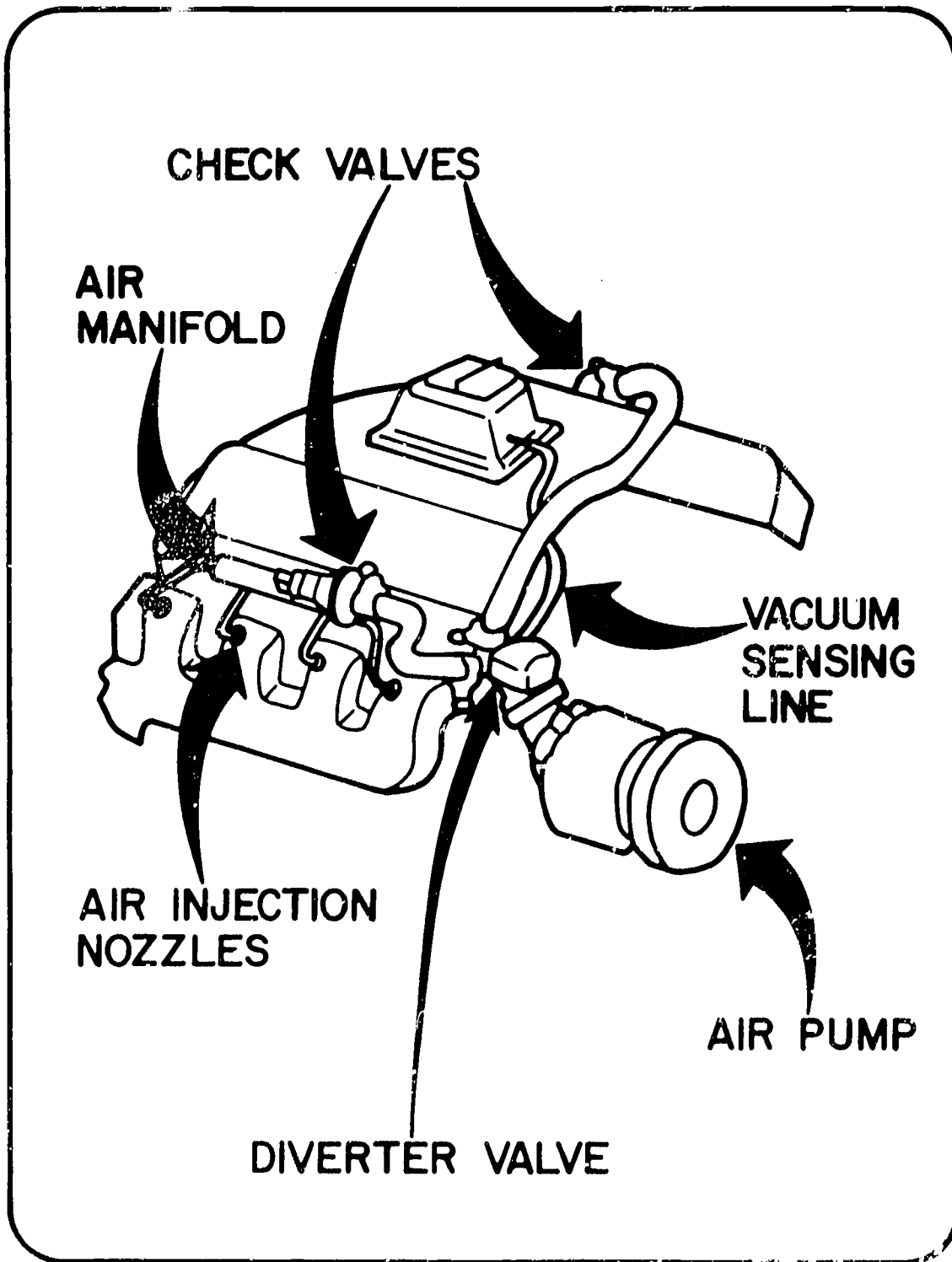

AIR INJECTION TUBE IN EXHAUST PORT

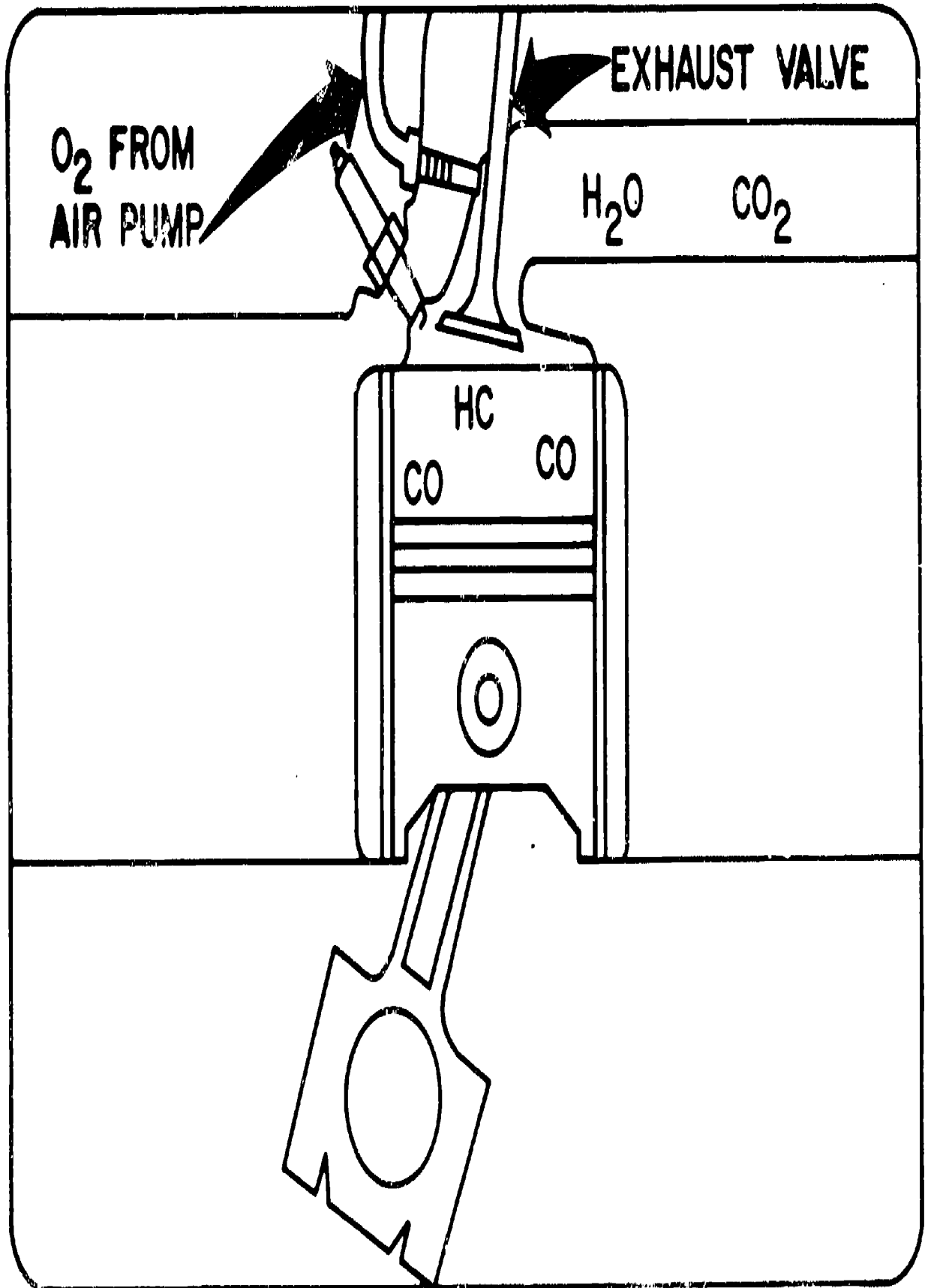

TM-1A

AIR PUMP COMPONENTS & OPERATION

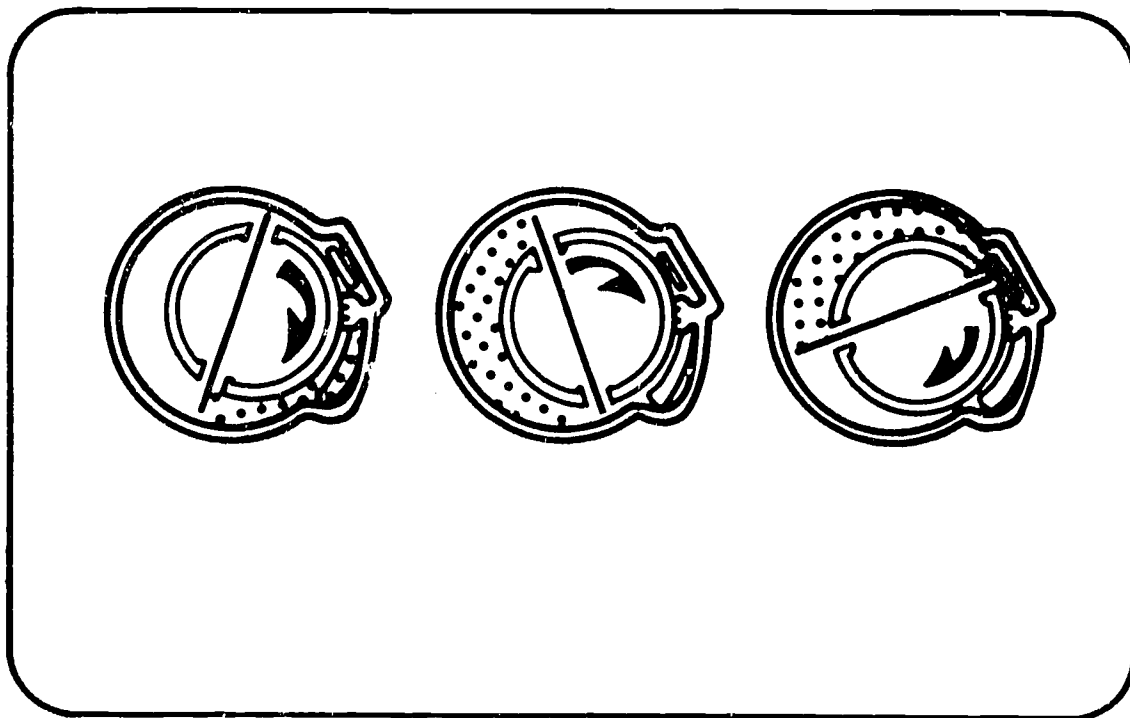
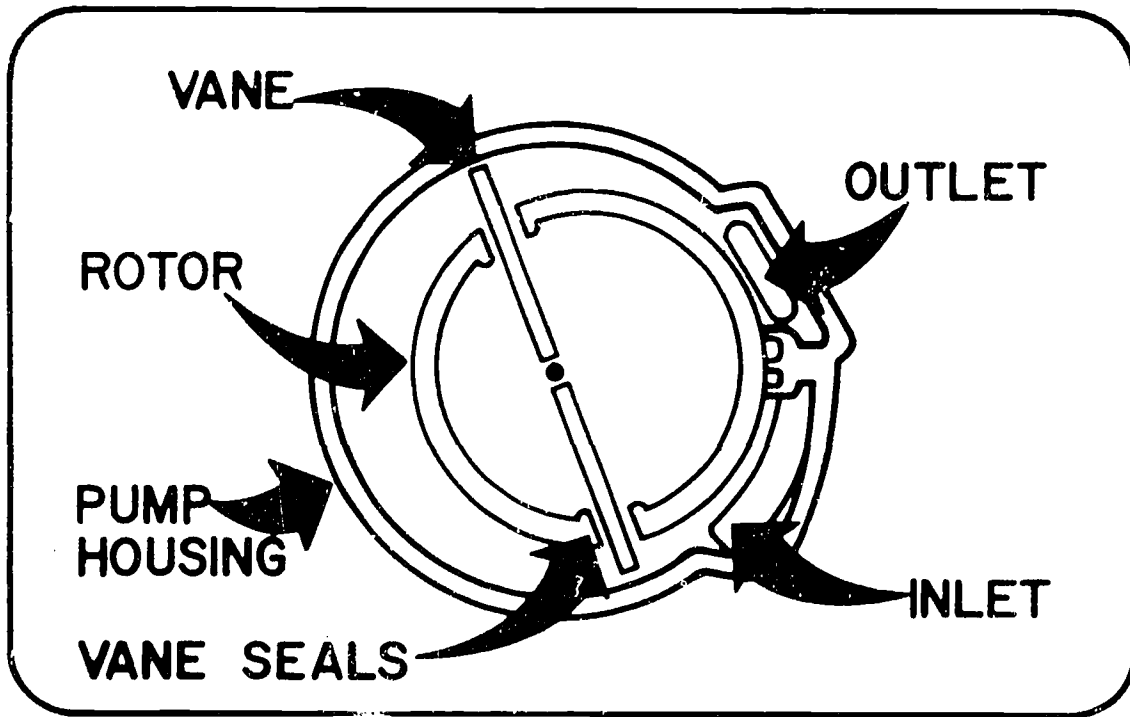

EXTERNAL MUFFLER TYPE DIVERTER

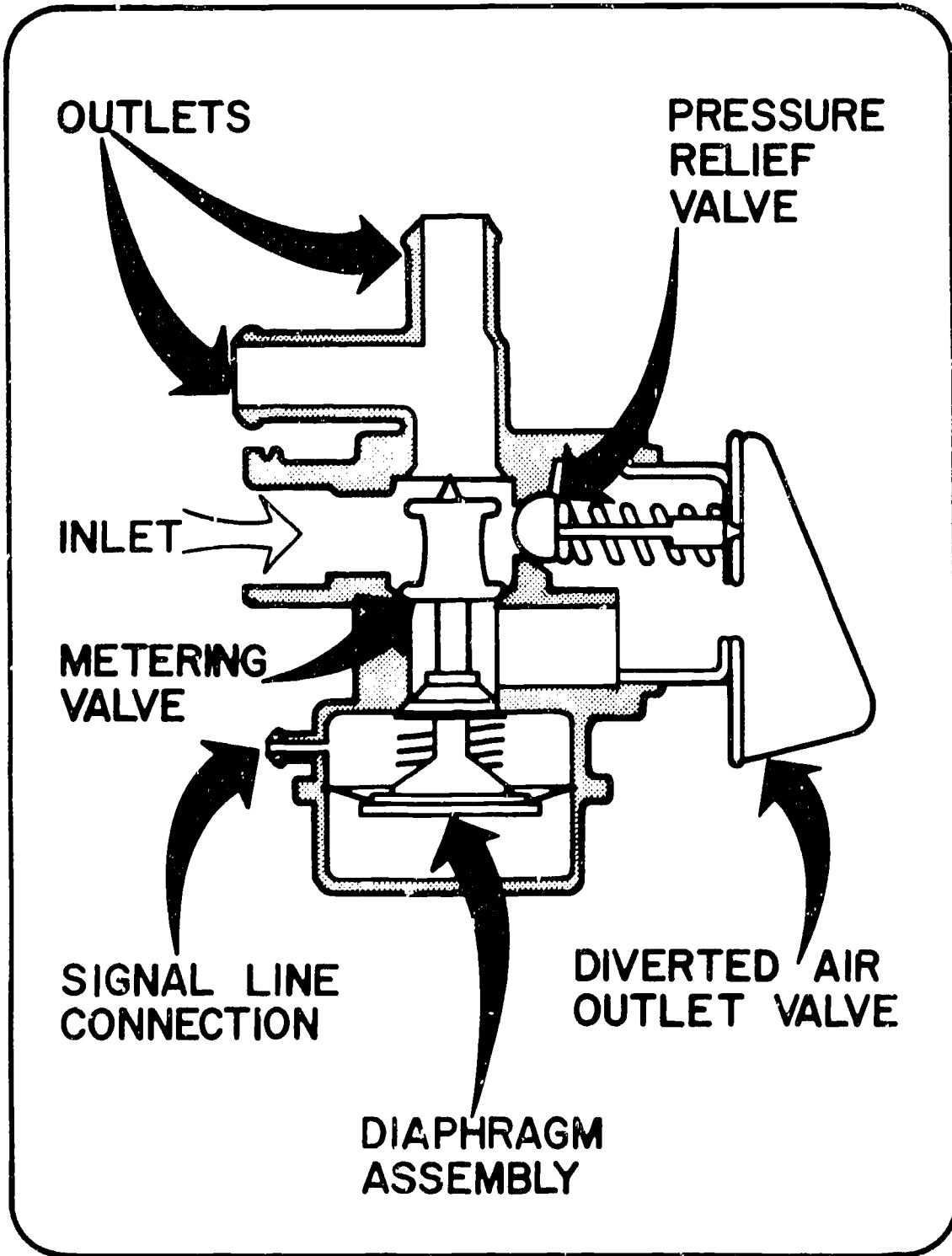

CHECK VALVE ASSEMBLY

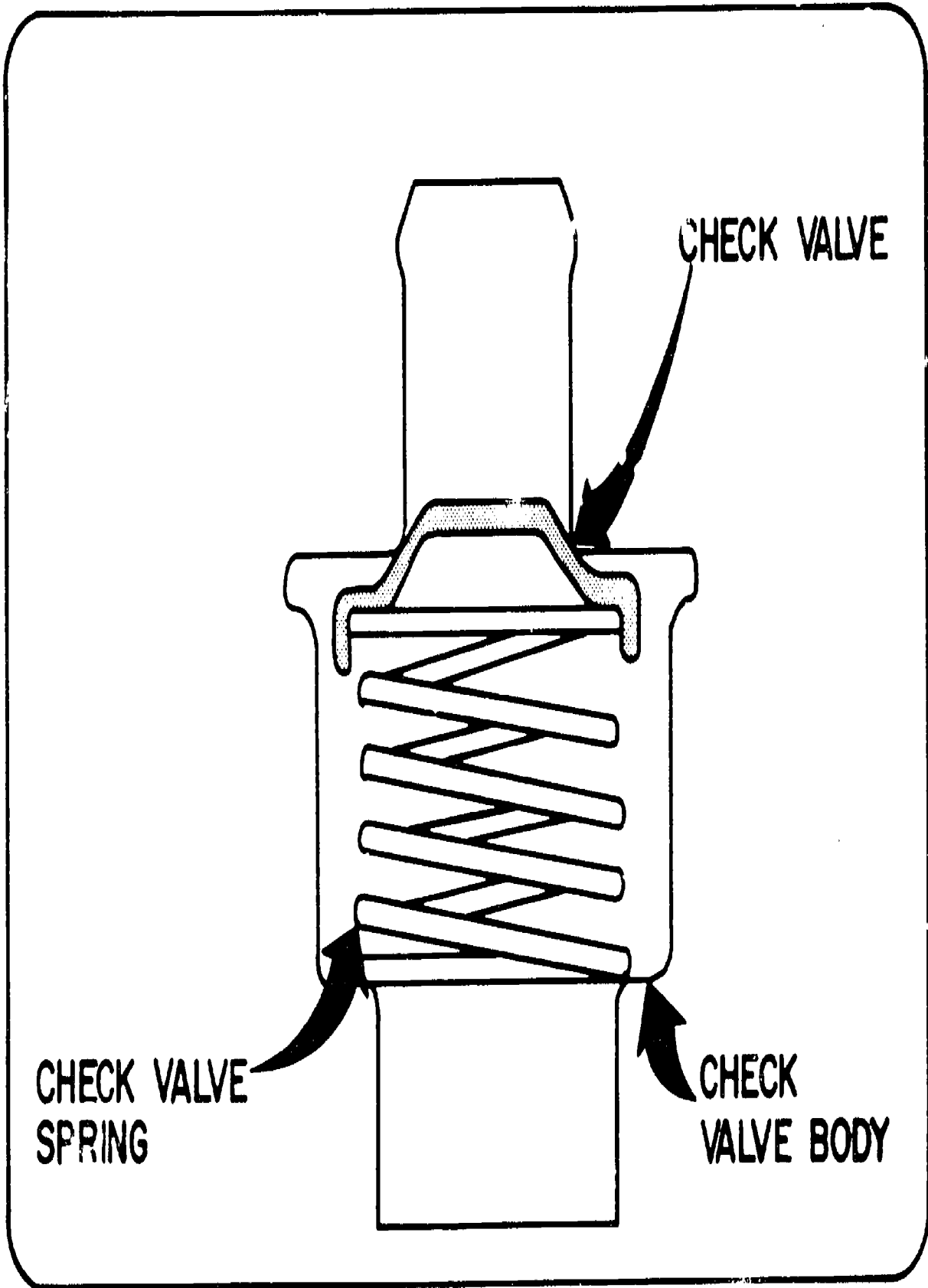

AIR INJECTION SYSTEM

UNIT 13

JOB SHEET #1 - VISUALLY INSPECT AIR MANIFOLD AND HOSES

I. Tools required

Hand tools as needed

II. Procedure

- A. Inspect air manifold for holes and fractures.
- B. Inspect hoses for cracks, deterioration, holes and routing (no kinks or sharp bends).
- C. Inspect and check all hose and manifold connections for tightness.

NOTE: Soapy water can be used to check connections on pressure side of system.

CAUTION: DO NOT GET ANY WATER NEAR A TWO VANE PUMP
CENTRIFUGAL FILTER. THIS CAN DESTROY THE PUMP.

NOTE: These are BASIC PROCEDURES. Check the manufacturers service shop manual or technical manual for exact procedures for each make and model.

JOB SHEET #2 - INSPECT DRIVE BELT AND SET CORRECT TENSION

I. Tools and Equipment

- A. Hand tools as needed
- B. Pry bar
- C. Belt tension gauge

II. Procedure

- A. Turn belt over and visually inspect for wear, cracks and deterioration. Replace if necessary.
- B. Check appropriate service manual for correct belt tension setting.
- C. Using belt tension gauge, check belt tension.
- D. If tension of belt must be reset, loosen appropriate bolt(s).
- E. Pry against rear cover only to establish proper belt tension.
- F. Tighten bolt(s) loosened in D.

NOTE: These are BASIC PROCEDURES. Check the manufacturers service shop manual or technical manual for exact procedures for each make and model.

JOB SHEET #3 - CHECKING AIR PUMP OUTPUT

I. Tools required

Hand tools as needed

II. Procedure

- A. Loosen clamp and remove one outlet hose.
- B. Start the engine.
- C. Check the air flow from the outlet.
- D. Accelerate engine to approximately 1500 rpm. Air flow should increase as engine speed increases.
- E. If air flow does not increase, check for air flow out of the diverter valve muffler.
- F. Shut off engine.
- G. Reconnect hose.
- H. Tighten clamp.
- I. Start engine and check for air leaks on reconnected hose.

NOTE: These are BASIC PROCEDURES. Check the manufacturers service manual or technical manual for exact procedures for each make and model.

JOB SHEET #4 - CHECK DIVERTER VALVE OPERATION

I. Tools required

Hand tools as needed

II. Procedure

- A. Warm engine to operating temperature.
- B. Disconnect vacuum signal line at diverter valve and check for vacuum by placing finger over the end of the line.
- C. Reconnect the vacuum signal line.
- D. Check diverter valve muffler for escaping air, (there should be none).

NOTE: If air is escaping, check all lines for kinks and/or bends that may be restricting air flow causing the pressure relief valve to open.

- E. Place hand by diverter valve muffler and quickly open and then close the throttle. A blast of air should come out of the muffler for approximately one second.
- F. If blast of air is felt, valve is operating satisfactorily.

NOTE: These are BASIC PROCEDURES. Check the manufacturers service shop manual or technical manual for exact procedures for each make and model.

JOB SHEET #5 - INSPECT CHECK VALVE OPERATION

I. Tools required

Hand tools as required

II. Procedure

A. Disconnect hose going to check valve.

B. Remove check valve from air manifold.

NOTE: Be careful not to twist or bend the air manifold.

C. Blow through the check valve (in direction of air flow) and then try to drain back (flow should be in one direction only).

D. Reinstall check valve in manifold.

E. Reconnect and tighten line to check valve.

NOTE: These are BASIC PROCEDURES. Check the manufacturers service shop manual or technical manual for exact procedures for each make and model

AIR INJECTION SYSTEM

UNIT 13

T E S T

1. What is the purpose of the air injection system?

2. Write the purpose of each of the components of an air injection system.
 - a.

 - b.

 - c.

 - d.

 - e.

 - f.

3. Identify the components of the air-fuel injection system.

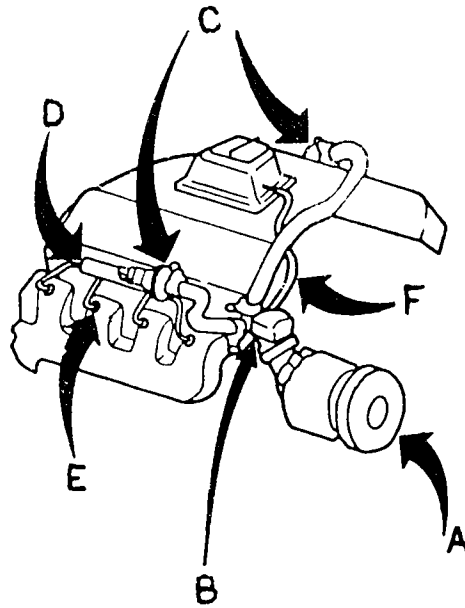

a.

b.

c.

d.

e.

f.

4. Identify the five main parts of the air pump.

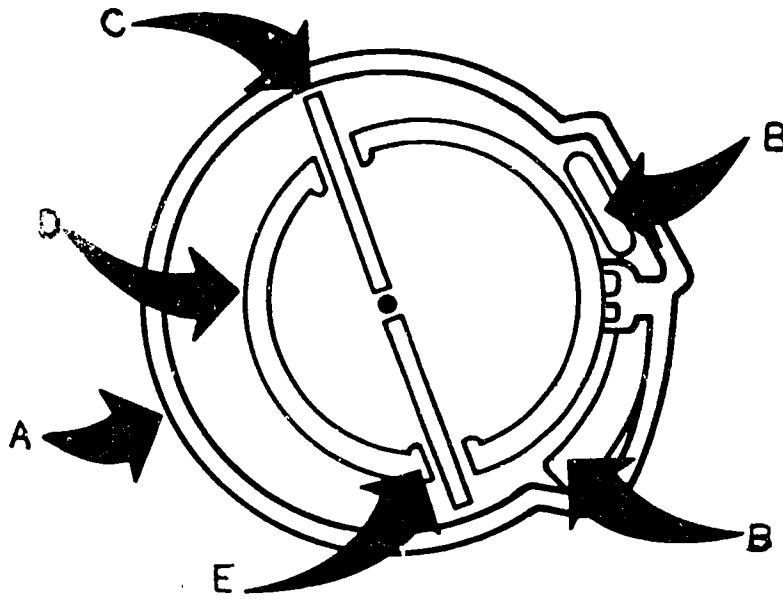

a.

b.

c.

d.

e.

5. Identify the parts of the diverter valve.

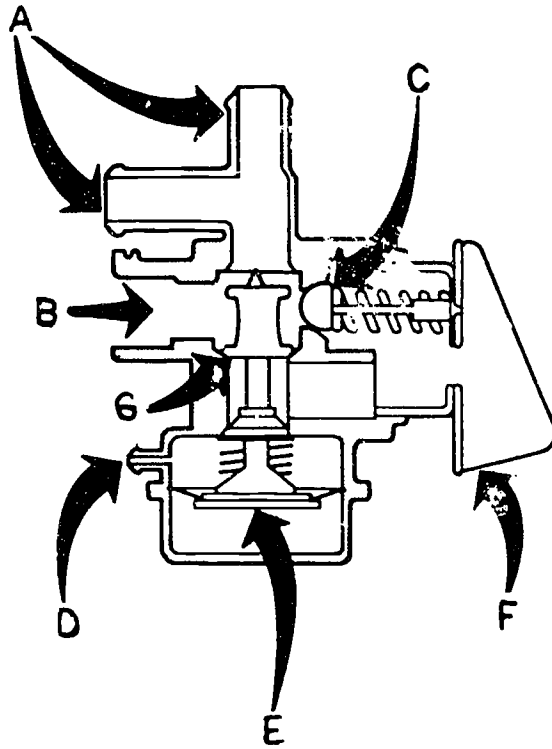

- a.
- b.
- c.
- d.
- e.
- f.
- g.

6. How does the diverter valve prevent backfire in the exhaust system?

7. The student should demonstrate the ability to perform the following jobs to the satisfaction of the instructor:

- a. Inspect air manifold and hoses.
- b. Inspect drive belt and set correct tension.
- c. Check air pump output.
- d. Check diverter valve operation.
- e. Check the check valve operation.

AIR INJECTION SYSTEM

UNIT 13

ANSWERS TO TEST

1. What is the purpose of the air injection system:

To supply additional oxygen at the exhaust ports in the vicinity of the exhaust valves and thereby extend the combustion process into the exhaust system which leads to a reduction in unburned hydrocarbon and carbon monoxide emissions.

2. Write the purpose of each of the components of an air injection system.

- a. Air Pump - Supplies filtered low pressure air to the system.
- b. Diverter Valve - Diverts air pump output to atmosphere during deceleration to prevent backfire and has a built-in pressure relief valve to protect the system.
- c. Check Valve - Prevents hot exhaust gases from backing up into the hoses and pump.
- d. Air Manifold - Distributes air to each cylinder.
- e. Air Nozzles - Injects air to each exhaust passage in the near proximity of the exhaust valves.
- f. Manifold Vacuum Signal Line - Senses manifold vacuum to actuate the diverter valve.

3. Identify the components of the air injection system.

- a. Air pump
- b. Diverter valve
- c. Check valve
- d. Air manifold
- e. Air nozzles
- f. Manifold vacuum signal line

4. Identify the five main parts of the air pump.
 - a. Housing
 - b. Inlet and Outlet
 - c. Vanes
 - d. Rotor
 - e. Seals

5. Identify the components of the diverter valve.
 - a. Air outlets
 - b. Air inlet
 - c. Pressure relief valve
 - d. Manifold vacuum signal line connection
 - e. Diaphragm assembly
 - f. Inverted air outlet
 - g. Metering valve

6. How does the diverter valve prevent backfire in the exhaust system?
 - a. During normal operation the pump discharge enters the diverter valve, passes by the metering valve and is discharged to the air manifold.
 - b. During deceleration, the carburetor throttle valves are nearly closed causing a rich air-fuel mixture and high manifold vacuum in the intake manifold.
 - c. This rich mixture will not undergo complete combustion and will allow an excessively rich mixture in the exhaust system.
 - d. The air supplied by the air pump will provide enough oxygen to ignite this rich mixture and cause a backfire.
 - e. The diverter valve senses the high intake manifold vacuum through the signal line connection.
 - f. This pulls up the diaphragm assembly which in turn raises the metering valve blocking off the outlet and opening the port to the diverted air outlet.

CATALYTIC CONVERTER SYSTEMS

UNIT 14

TERMINAL OBJECTIVE

After completion of this unit the student will be able to explain the purpose of catalytic converters and explain the systems and components needed to protect the catalytic converters.

This will be evidenced by scoring 85% minimum on the unit test.

SPECIFIC OBJECTIVES

After completion of this unit the student will be able to:

1. Write the purpose of catalytic converters.
2. Identify and give the function of catalytic converter components.
3. Write the purpose of catalytic converter protection systems.
4. List the components of a catalytic converter protection system.
5. Explain the operation of a catalytic converter protection system.
6. Write the purpose of heat shields.
7. Write the reason for the use of non-leaded fuels in catalytic converter equipped cars.

CATALYTIC CONVERTER SYSTEM

UNIT 14

SUGGESTED ACTIVITIES

I. Instructor

- A. Provide students with objective sheet
- B. Provide students with information sheets
- C. Make transparencies
- D. Discuss terminal and specific objectives
- E. Discuss information sheets

NOTE: It is suggested that the instructor make up job sheets according to the specific make and model of vehicle available to the shop.

F. Give test

II. Student

- A. Read objective sheet
- B. Study information sheet
- C. Take test

INSTRUCTIONAL MATERIALS

I. Included in this unit:

- A. Objective sheet
- B. Information sheet
- C. Transparency masters

14-IM-1 Exhaust System With Catalytic Converter

14-IM-2 Catalytic Converter Components

14-IM-3 Catalyst Protection System

14-IM-4 Heat Shields

14-IM-5 Unleaded Fuel Filter Inlet

D. Test

E. Answers to test

II. References

1. 1975 Chevrolet Service Manual Supplement (contact local dealer).
2. Chrysler Corporation. 1975 Passenger Car Service Highlights, Technical Training Booklet.
3. Chrysler - Plymouth - Dodge Service Manual, 1975 (consult local dealer).
4. Ford Service Manual Supplement, 1975 (consult local dealer).
5. Glenn, Harold T. The 1975 Cars -- New Concepts for the Auto Shop School Shop, Industrial-Technical Education, Oct. 1974.
6. Glenn, Harold T. Glenn's Emission Control Systems, Chicago, Ill., Henry Regnery Co., (1972).
7. Henein, N. A. and Patterson, D. J. Emissions From Combustion Engines and Their Control, Ann Arbor Science Publications, Inc., Ann Arbor, Mich. (1972).

CATALYTIC CONVERTER SYSTEM

UNIT 14

INFORMATION SHEET

I. PURPOSE OF CATALYTIC CONVERTERS - TM-1

To speed up the oxidation of hydrocarbons and carbon monoxide which results in the hydrocarbons (HC) being converted to water (H_2O) and the carbon monoxide (CO) being converted to carbon dioxide (CO_2).

II. CATALYTIC CONVERTER COMPONENTS - TM-2

A. Stainless Steel Shell - Houses the oxidizing bed or catalyst.

B. Catalyst - Beads or a porous material called a monolith, that are either aluminum or ceramic and are coated with a catalytic agent consisting of palladium and platinum. These serve to speed the oxidation of hydrocarbons and carbon monoxide.

NOTE: Ford and Chrysler are using monolithic elements, General Motors is using beads or pellets.

C. Stainless Steel Mesh - Houses the monolithic elements and acts as a cushion to protect the elements from damage.

D. Flow Diffuser - Spreads out the exhaust flow to give a more even flow through the monolithic elements.

E. Analyzer Access Plug - Located ahead of the flow diffuser and catalytic element to allow the use of an infra red exhaust analyzer during tuneups.

III. PURPOSE OF CATALYTIC CONVERTER PROTECTION SYSTEMS - To protect the catalytic from overheating and damage especially during periods of deceleration.

IV. CATALYST PROTECTION SYSTEM COMPONENTS - TM-3

- A. Electronic Control Unit - Part of the electronic ignition system that receives triggering impulses from the distributor and initiates ignition coil discharge.
- B. Electronic Speed Switch - Receives ignition pulses from the electronic control unit thus sensing engine speed and energizing throttle position solenoid at a preset engine rpm.
- C. Throttle Position Solenoid - Holds the throttle at a preset position when energized by a signal from the electronic speed switch.

V. OPERATION OF THE CATALYST PROTECTION SYSTEM

- A. When engine speed exceeds 1800 rpm, the throttle position solenoid receives a signal from the electronic speed switch.
- B. When the throttle is released, the throttle position solenoid prevents the throttle from closing beyond a preset point that corresponds to 1500 rpm.

When sharp deceleration of the throttle is allowed to occur at idling position, the catalytic converter is damaged by high temperature. If it is not damaged, the increased amount of carbon monoxide by burning the fuel at a higher idling speed may be admitted and allow carbon deposits to form and prevent the engine from idling smoothly.

The speed and throttle position sensor, when equipped, controls the speed and throttle position solenoid. The solenoid is energized by the electronic control unit when the engine speed exceeds the preset rpm. The solenoid holds the throttle at a preset position when the engine speed is above the preset rpm.

VI. PURPOSE OF HEAT SHIELDS - TM-4 - To protect components and body areas such as passenger compartment, trim and chassis parts from damage that could be caused by the high catalytic converter temperatures.

NOTE: Catalytic converters operate between 752°C(1400°F) and 862°C(1600°F) under normal conditions.

VII. REASON FOR THE USE OF NON-LEADED FUELS ONLY - TM-5 - To prevent the coating of the catalyst with the tetraethyl lead (TEL) found in leaded fuels. If leaded fuels are used, the catalyst is coated with lead and this deactivates the catalyst making replacement necessary.

NOTE: Beginning in 1975 all cars using catalytic converters will have a smaller fuel tank inlet that will only accept the smaller, lead-free gas fuel nozzles.

EXHAUST SYSTEM WITH CATALYTIC CONVERTER

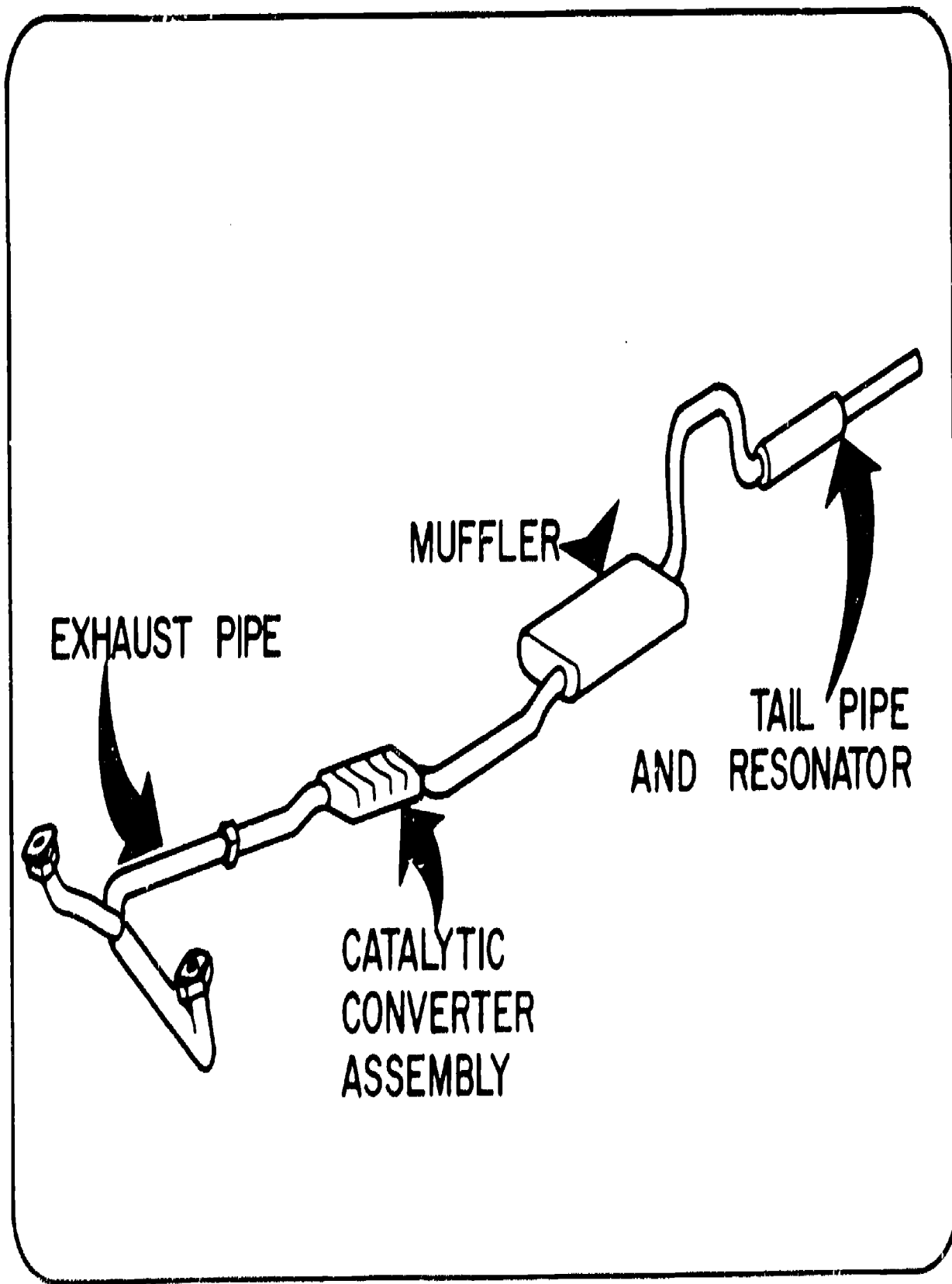

T M

CATALYTIC CONVERTER COMPONENTS

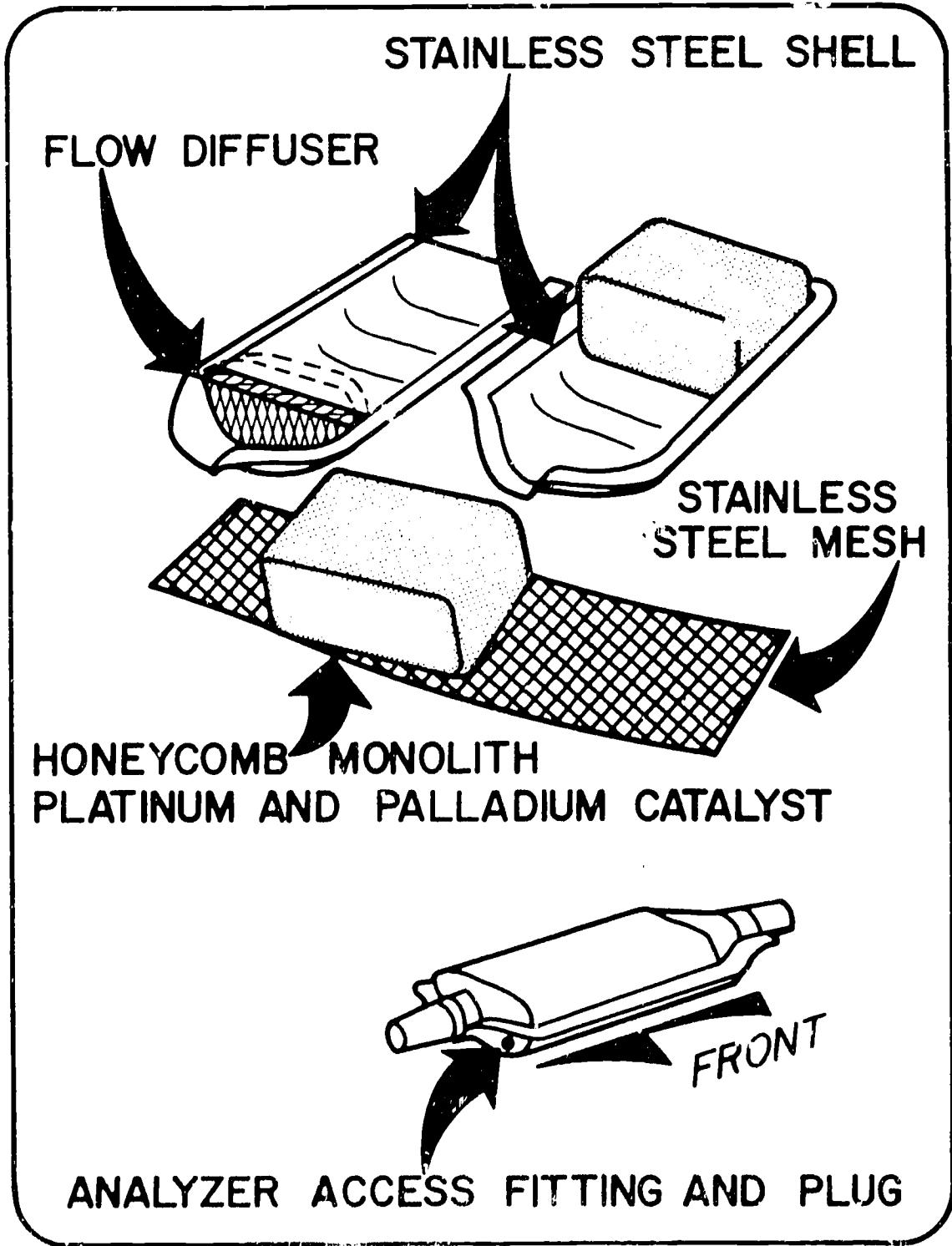

CATALYST PROTECTION SYSTEM

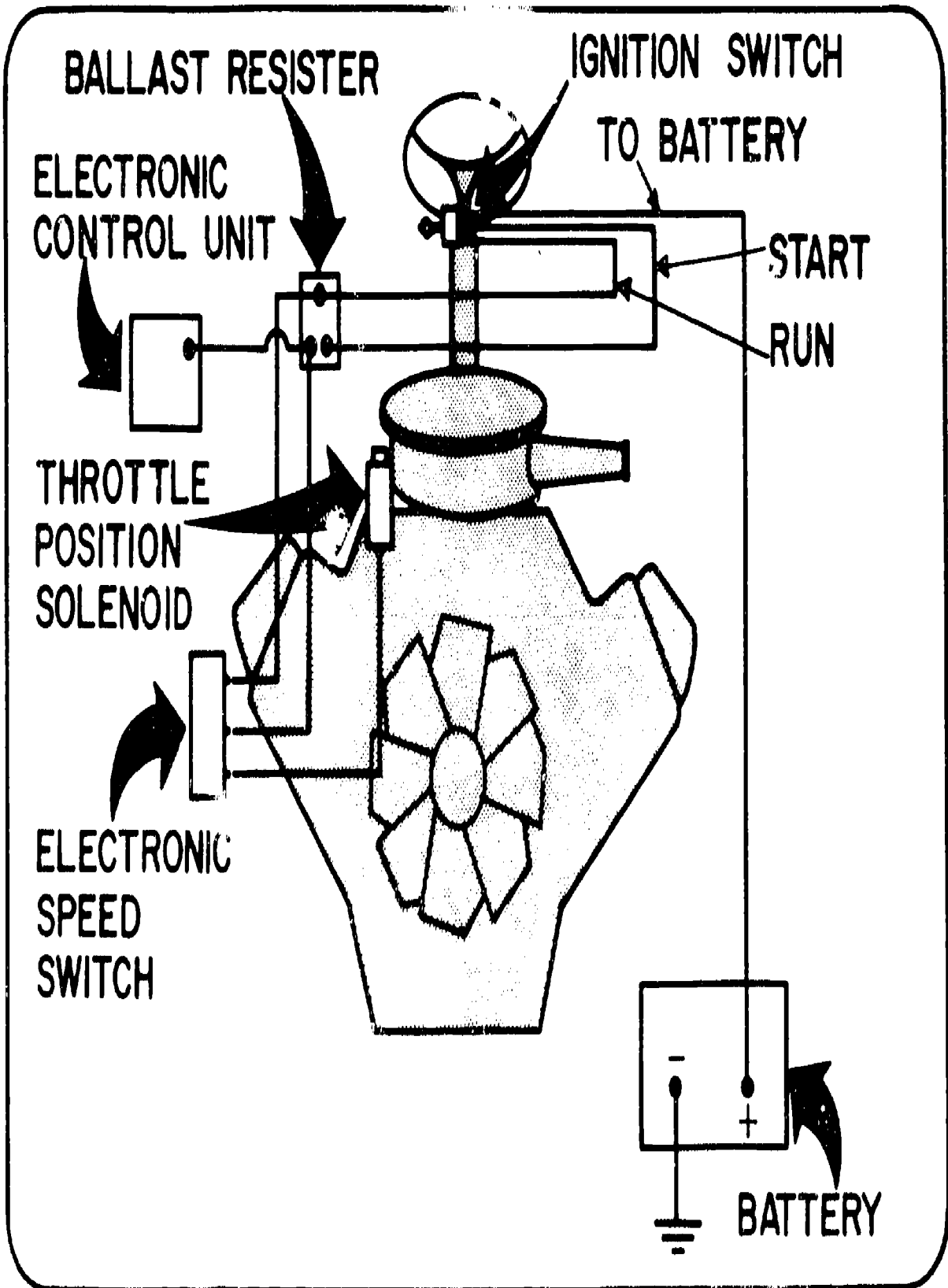

HEAT SHIELDS

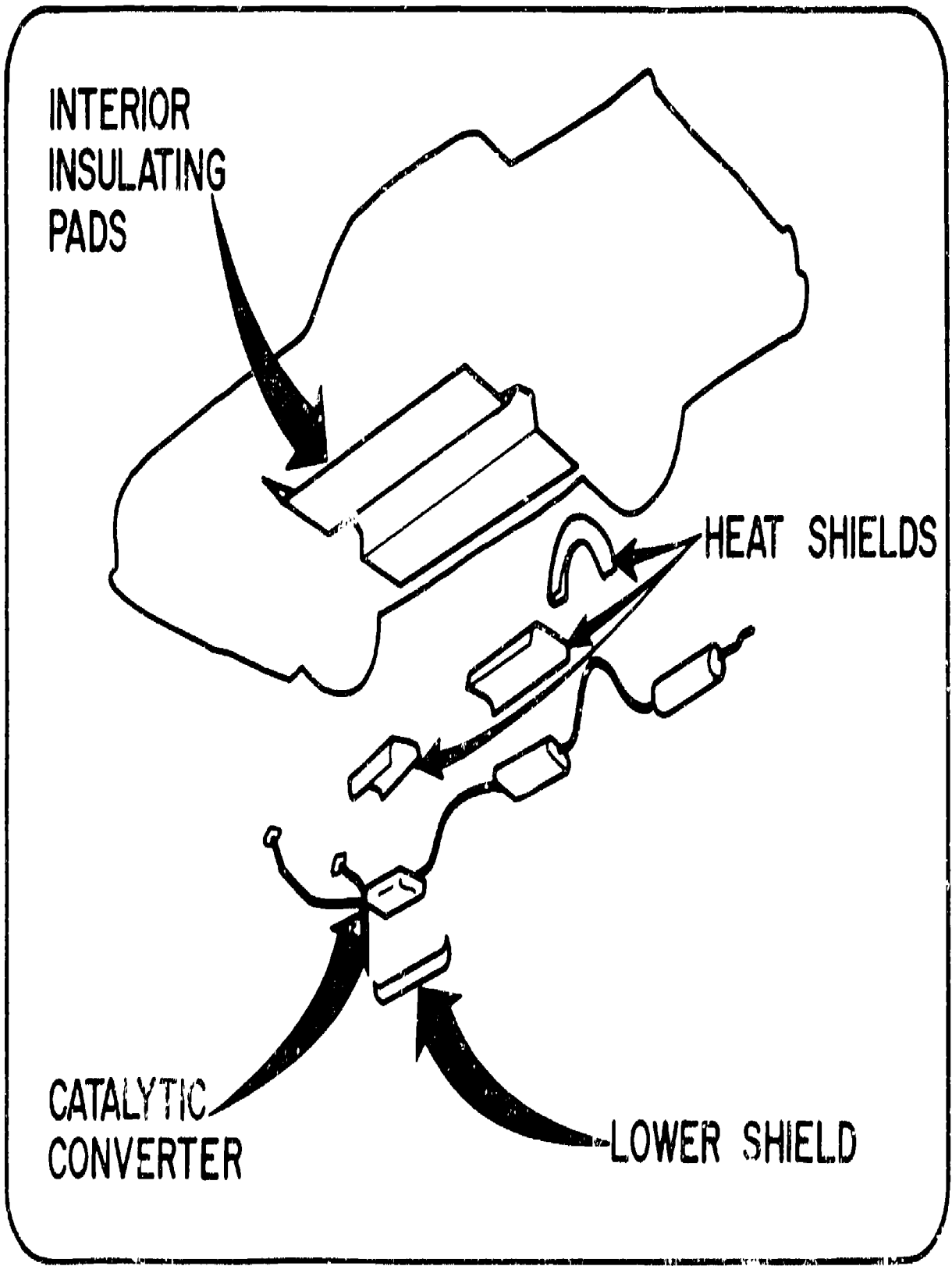

UNLEADED FUEL FILLER INLET

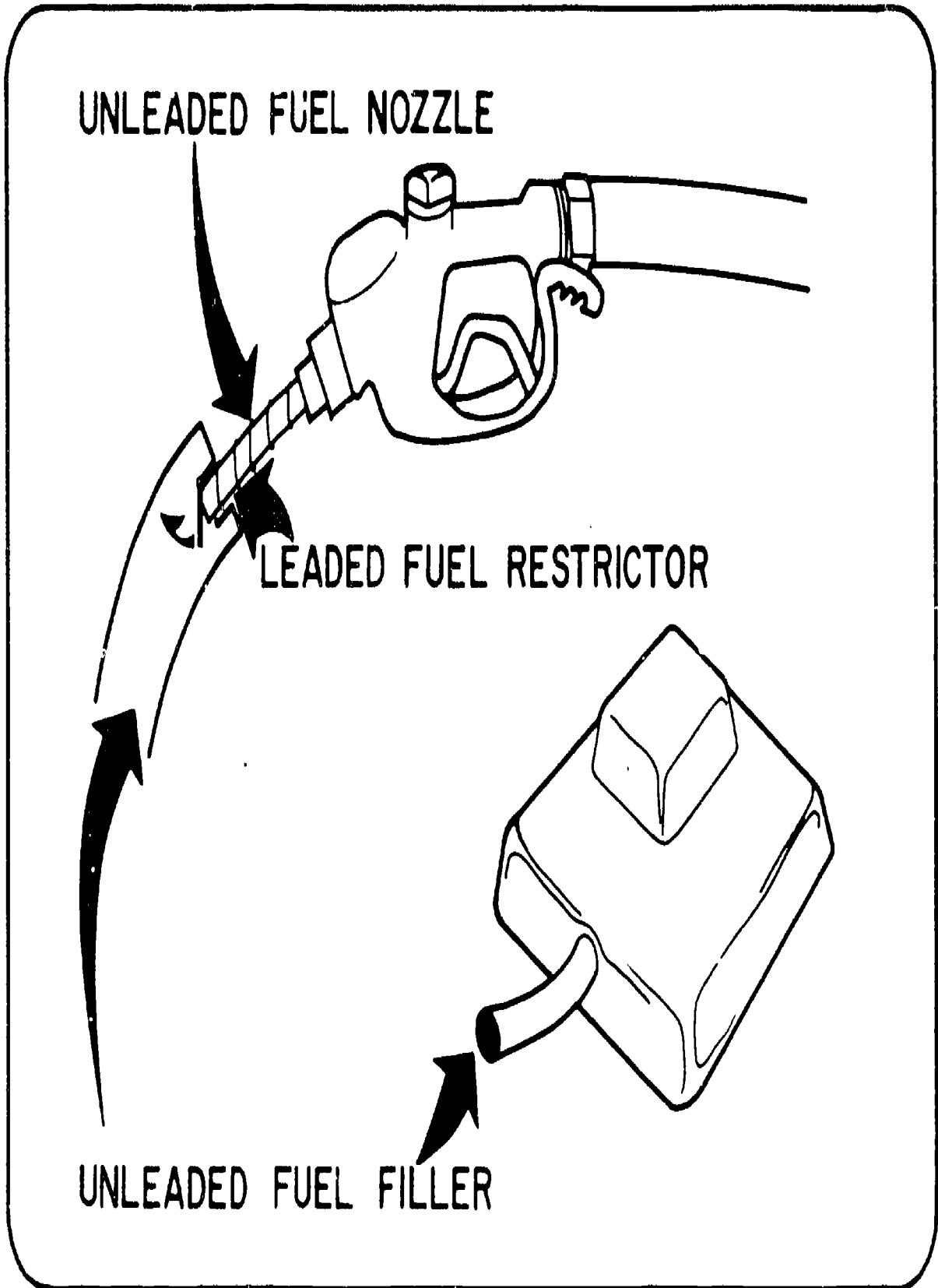

CATALYTIC CONVERTER SYSTEM

ENR 114

TEST

1. What is the purpose of catalytic converters?

2. Identify and give the function of each catalytic converter component.

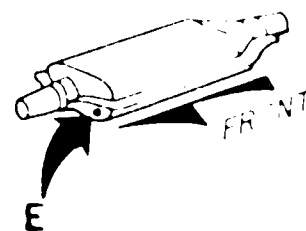
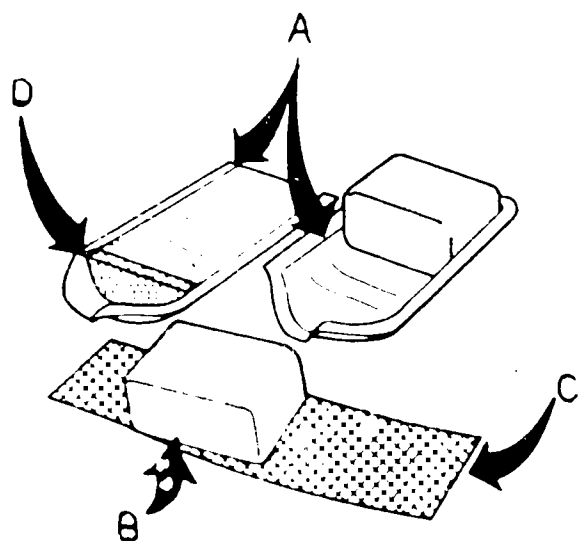

a.

b.

c.

d.

275. *Method for detecting a fault in a power inverter*, method, by G. J. ...

2

276. *Method for detecting a fault in a power inverter*, method, by G. J. ...

277. *Method for detecting a fault in a power inverter*, method, by G. J. ...

2

6. Write the purpose of heat shields.

7. What is the reason for using non-leaded fuels only on catalytic converter equipped cars?

CATALYTIC CONVERTER SYSTEM

UNIT 14

ANSWERS TO TEST

(Main Points)

1. What is the purpose of catalytic converters?

To speed up the oxidation of HC and CO to H₂O and CO₂ and reduce emissions.

2. Identify and give the function of each catalytic converter component.

a. Stainless Steel Shell - Houses the oxidizing bed or catalyst.

b. Catalyst - Beads or monolith that are coated with palladium and platinum that speed up the oxidation of HC and CO.

c. Stainless Steel Mesh - Protect monolithic elements from damage.

d. Flow Diffuser - Spreads out exhaust gases and gives more even flow through catalyst.

e. Analyzer Access Plug - Allows the use of infra red exhaust analyzer during tuneup.

3. What is the purpose of the catalytic converter protection system?

To protect the catalyst from overheating and damage especially during periods of deceleration.

4. List the components of the catalytic converter protection system.

a. Electronic control unit.

b. Electronic speed switch.

c. Throttle position solenoid.

When the operation of the catalytic converter protection system is initiated, the engine speed is greater than 1500 rpm, the throttle position sensor is energized by the electronic control system, and the throttle is released, the throttle position sensor prevents the throttle from closing beyond a 1500 rpm setting. When the engine speed drops to less than 2000 rpm, the electronic system deenergizes the throttle position solenoid and throttle returns to the normal idle position.

State purpose of heat shields.

Heat shields protect engine components and the passenger compartment from the heat generated by the catalytic converter.

State one reason for using non-leaded fuels only on catalytic converter equipped cars?

Lead in the fueling and heat action of the catalyst that results in the poisoning of the leaded fuel.

971 6552 20